

SmartROC T30 RX

Tophammer surface drill rig for quarrying and construction

Hole diameter: 64-102 mm (2.5-4.0")



Power — right where you need it

A smart, capable and rugged partner which has all the power you need to get the job done.

You work alone in the background, — building the infrastructure which keeps society running smoothly. You are first on-site and the last to go home. We know how it is. Epiroc has designed this rig to work as hard as you do.

The SmartROC T30 RX will follow you into the roughest terrain, or the most remote work site. The COP SC19 HE rock drill is matched with a powerful compressor allowing this rig to punch well above its weight. This enables you to get the job done — with speed and efficiency.



Discover more about
the SmartROC T30 RX.

Your new best friend

The SmartROC T30 RX features a smart control system (RCS) which presents you with all the information you need to get the job done. It features an intuitive 10" touchscreen display so you can keep track of drilling operations and rig settings. The control system also automatically optimizes power output which reduces fuel consumption. This helps to keep costs low and reduce your environmental impact. A SmartROC rig also logs valuable data during drilling which can be downloaded and analyzed to further improve operations.

The Smart RCS also opens the door to automation plus many valuable options. This rig includes a rod handling system which increases consistency, reduces wear on consumables and boosts productivity.

The Hole Navigation System (HNS) option allows you to upload a pre-prepared drill plan. Each hole can then be drilled with extreme accuracy without the need for manual marking. This saves time and cuts down on the amount of explosives used.

Epiroc is constantly pushing and developing updates, new features and options for SmartROC rigs. These can be installed in your SmartROC T30 RX in the future thanks to the Smart control system. This helps to safeguard your investment, further boost productivity and keep your most trusted workmate in top condition.

⊕ Main benefits

Powerful. The SmartROC T30 RX is fitted with the rugged COP SC19 HE rock drill, a compressor delivering 105 liters FAD (28 US gals) and a modern Volvo Penta diesel engine providing 129 kW (173 hp). All these features ensure that this rig packs a powerful punch for its size.

Capable. A 39°/34° horizontal coverage area coupled with a 4.75 m boom reach allows you to drill a good number of holes between setups. The tracks are long and widely-spaced to give good stability. The high ground clearance ensures that the rig can get into rough sites and get the job done.

Smart. A SmartROC rig features a high level of automation along with impressive, production-boosting options such as the Hole Navigation System. Easily-installed updates safeguard your investment and keep your rig up-to-date.



Despite its compact size, the SmartROC T30 RX has the power you need. If you need to drill in hard rock conditions in rough terrain, this rig will be able to access the site and get the job done thanks to its high-capacity compressor, powerful rock drill and modern diesel engine.



The SmartROC T30 RX is easy and cost effective to transport due to its well-balanced, compact, thought-out design. It's also simple to service thanks to large access hatches. Service points are grouped together to make life easier.



Extra LED lighting options are available to ensure that you are never left in the dark – wherever you are working. The powerful lighting package ensures that you have good visibility all round the rig and over the drill area.

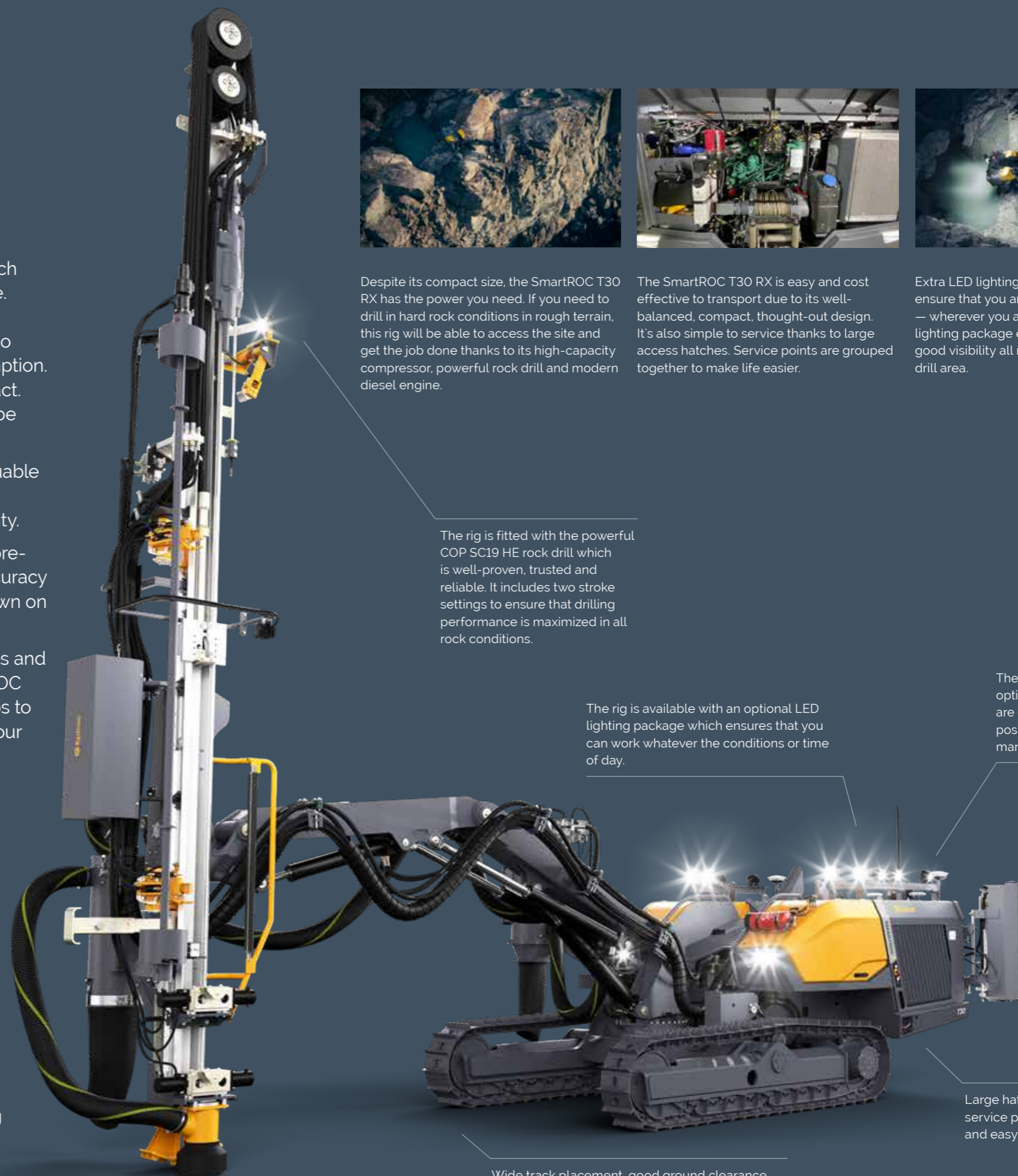

The rig is fitted with the powerful COP SC19 HE rock drill which is well-proven, trusted and reliable. It includes two stroke settings to ensure that drilling performance is maximized in all rock conditions.

The rig is available with an optional LED lighting package which ensures that you can work whatever the conditions or time of day.

The Hole Navigation System option ensures that holes are drilled in exactly the right position without the need for manual marking.

Large hatches and grouped service points make for quick and easy servicing.

Wide track placement, good ground clearance combined with excellent balance ensure that this rig has impressive reach and coverage without compromising on safety or stability.

Powerful, capable and smart

A remote work site with tough rock conditions and rough terrain? No problem. You can count on your SmartROC T30 RX to get the job done rapidly and efficiently.

The SmartROC T30 RX features great ground clearance and is equipped with long crawler-tracks which are spaced widely to increase stability. This allows it to tram into those hard to reach areas.

It's not enough to just get to the hole site though! In order to make sure you can drill in the roughest conditions, the rig is fitted with a modern Volvo Penta diesel engine producing 129 kW (173 hp). The rig also includes a high-capacity compressor which can deliver 105 liters per second (28 US gals) of air. Combine these two with a super-efficient and powerful COP SC19 HE rock drill and you have an unbeatable package for this class of rig.

Designed for you — and all kinds of rock

We know that your job is anything but monotonous. Each day is different, and presents you with unique problems and challenges. The SmartROC T30 RX has been designed with this in mind. Impressive terrainability, a smart control system and a great power-to-weight ratio ensure that you can get where you need to be and drill quickly and efficiently.



+ Smart control system

The Smart control system enables you to tune the drilling process so that you can get the rock drill to perform to perfection. Its intuitive interface is easy to understand so you can get up and running in no time at all. The control system also makes it simple and quick to install new updates in the future. Engine RPM and compressor load are automatically adjusted by the system to ensure that maximum efficiency is achieved throughout the drilling process.



+ Reduced environmental impact

At Epiroc, our goal is to help your operation be as sustainable as possible. The rig is fitted with a Volvo Penta diesel engine with a smart control system which ensures that fuel is not used unnecessarily. This saves money and helps to reduce environmental impact. This engine also meets all the latest emissions regulations for use within the EU and USA.



+ Tough terrain? No problem

The SmartROC T30 RX has a low center of gravity to help it stay balanced on rough ground. We've also increased the space between the long crawler tracks which helps to improve stability. The boom is also extremely manoeuvrable which makes it a great counter-weight when tramping over uneven ground. A lab-type drill support leg is also fitted to ensure a stable set-up whilst a winch allows you to anchor the machine securely to get up and down steep inclines.



A comprehensive service offering

Even the best equipment needs to be serviced regularly to make sure it sustains peak performance. An Epiroc service solution offers peace of mind, maximizing availability and performance throughout the lifetime of your equipment. We focus on safety, productivity and reliability.

By combining genuine parts and an Epiroc service from our certified technicians, we safeguard your productivity – wherever you are.

Main Components

- Crawler type two speed undercarriage with track oscillation system
- Powerful COP SC19 HE rock drill with two stroke settings
- Volvo Penta diesel engine
- Atlas Copco screw type compressor
- Versatile folding boom system
- Labb-type drill support leg
- Dust pre-separator

- Double hose drum
- Rock drill lubrication-oil collection-system (ECLR)
- Movable suction hood/drill-steel support
- 7.5 meter (24.6 ft) feed
- Smart control system with 10" touchscreen
- Rod Handling Systems, RHS
- High capacity Dust Collection System, DCT
- Radio Remote Control system with integrated display

Recommended hole range

Feed type	Metric	US	Thread	Rod Handling System (RHS)
				4+1 rods
7.5 meter (24.6 ft) feed	Ø 64–102 mm	Ø 2.5"–4.0"	TC35, T35, T38, T45, T51	18 m (59 ft) max hole depth

Engine (HVO 100-compliant)

Volvo Penta turbo-charged diesel engine, Tier 4 Final/Stage 5	
Power rating at 1975 rpm	129 kW/173 hp
Electronic variable engine speed	900 – 1975 rpm
Variable fan control	
Green saver – automatic low engine speed	

Volvo Penta turbo-charged diesel engine, Tier 3	
Power rating at 1975 rpm	129 kW/173 hp

Dust collector DCT

	Metric	US
Filter area	7 m ²	75 sq.ft
Suction hose diameter	102 mm	4"
Cleaning air pressure, max	7.5 bar	109 psi
Cleaning air consumption at 7 bar	15 l/pulse	0.53 cu. ft/pulse
Filter cleaning while drilling		
7 pcs of filter elements		
Mounted on hydraulic swing arm		

Weight

Standard unit excluding all options and drill steel	Metric	US
Provisional max weight	13 100 kg	28 880 lbs

Compressor

Atlas Copco OIS, screw compressor		
Working pressure, max	10.5 bar	152 psi
FAD, at normal working pressure	105 l/sec	28 US gal/sec

Feed BMH 6000

Total length	7 500 mm (295')
Travel length	4 190 mm (165')
Feed extension	1 400 mm (55')

Hydraulic aluminum cylinder feed with hose guide and single drill steel support with moveable or fixed lower guide/dust hood.

Electrical system

Voltage	24 V
Batteries (AGM)	95 Ah
Alternator	28 V, 130 A
Work lights, front	2 X 35W LED
Work lights, rear	2 X 35W LED
Work lights, feed	2 X 56W LED
Display with diagnostics and settings	

Hydraulic rock drill

Rock drill	Power	Motor
COP SC19 HE	19.2 kW (25.5 hp)	160 cc
		250 cc
		315 cc

Features two stroke settings

Hydraulic system

Anti-jamming		
Rotation Pressure Control feed RPC-F		
Damper Pressure Control - impact DPC-I		
Return and drainage filters F (filtration rate)	10 µm absolute	
Hydraulic oil cooler max ambient temperature	50°C	122°F
(Diesel engine pre-heater required at -15°C)		

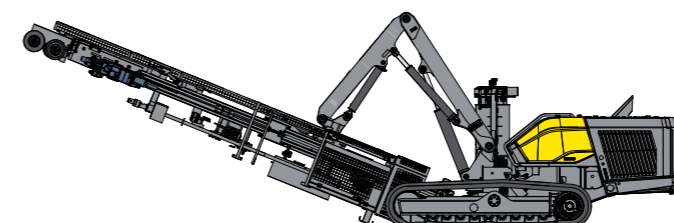
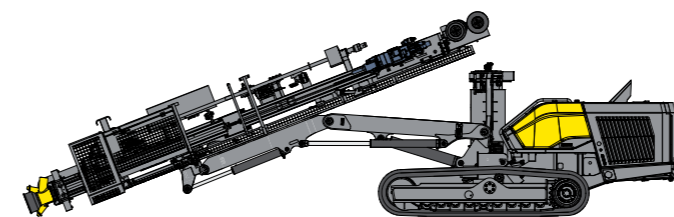

Transport dimensions 1

Height	2 900 mm (114')
Length	10 400 mm (410')
Width	2 450 mm (96.5')

Transport dimensions 2

Height	3 300 mm (130')
Length	11 000 mm (433')
Width	2 450 mm (96.5')

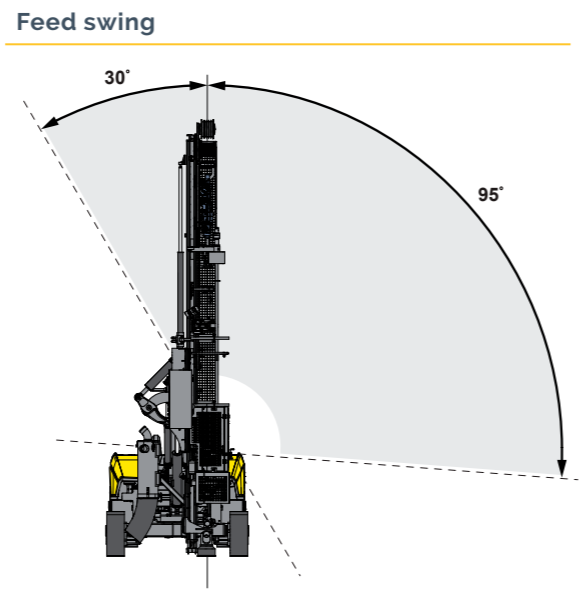
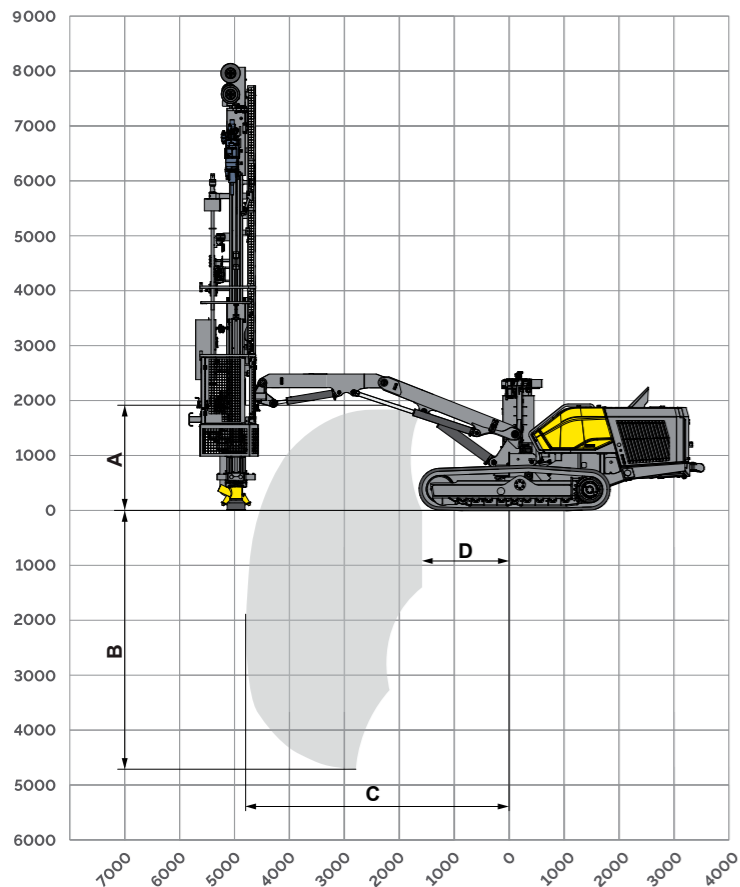
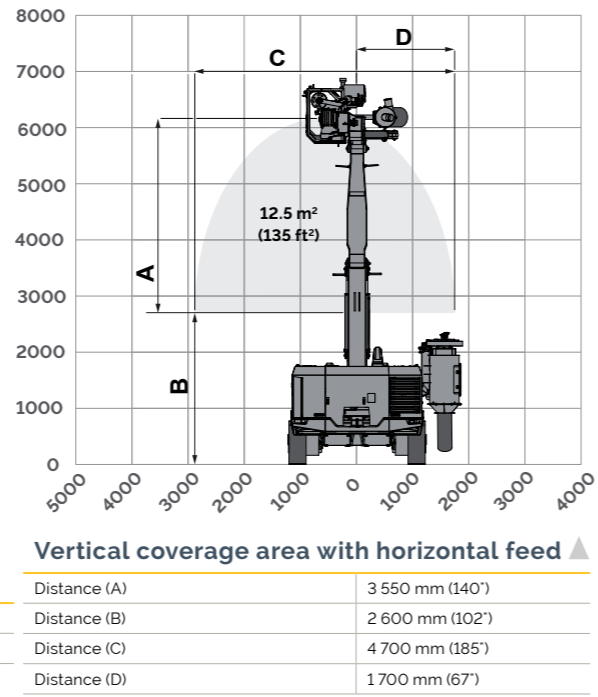
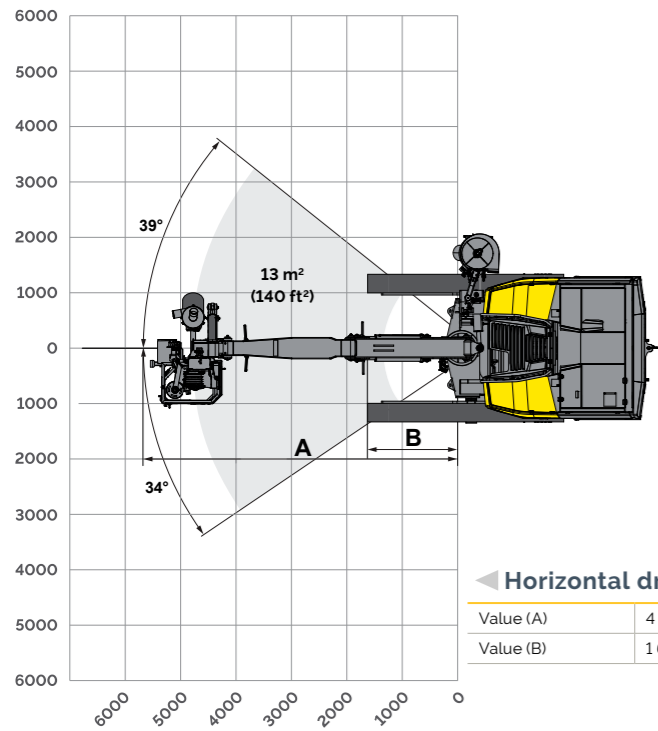

Drilling position dimensions

Height (A)	7 500 mm (295')
Height (B)	2 400 mm (95')
Length (C)	2 250 mm (89')
Length (D)	4 200 mm (165')
Length (E) with water mist tank	5 100 mm (201')

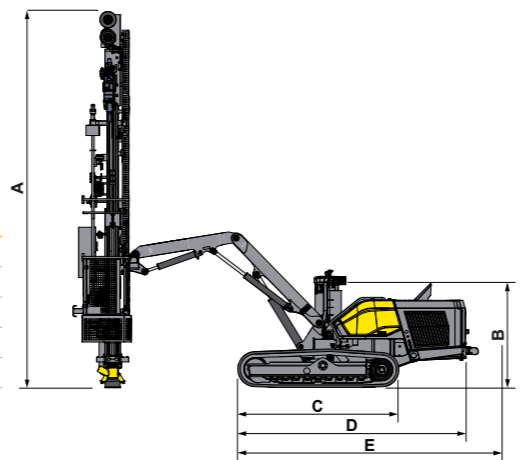

Horizontal side drilling area (right-hand side)

Distance (A)	5 100 mm (201')
Distance (B)	400 mm (16')
Distance (C)	1 500 mm (60')
Distance (D)	6 500 mm (256')

Max feed dump

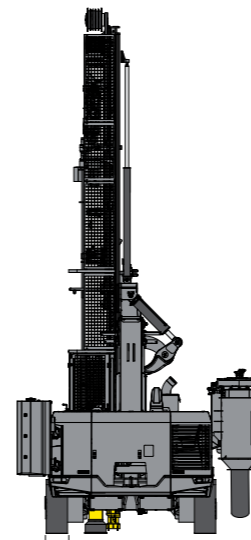
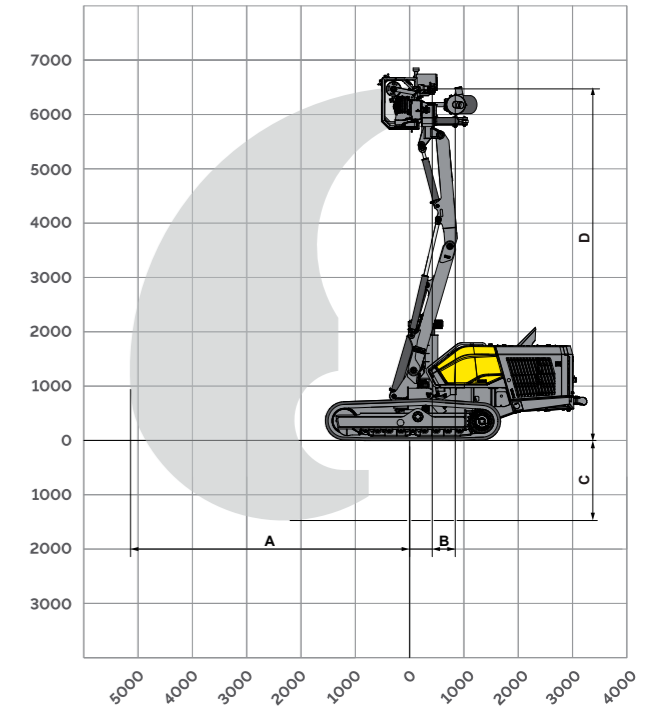
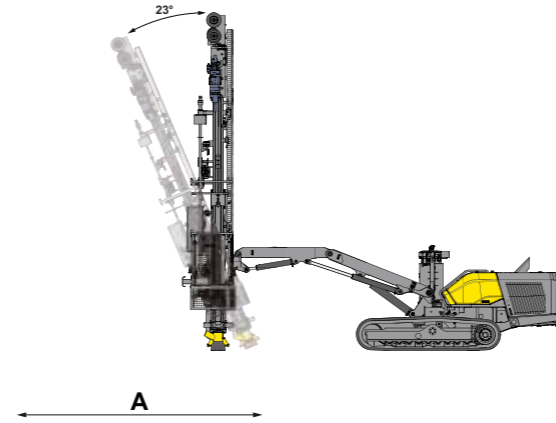

Minimum distance from drill center

Distance (A) - feed in vertical position	800 mm
Distance (C) - feed inclination	670 mm
Distance (B) - inclination	5°

Selection of options

Feed and boom

- Protection of Moving Parts (PoMP)
- Rubber disc for DCT
- Rubber hood for DCT
- Thread lubrication system - ECG
- Sleeve retainer
- Grease brush
- Auto RHS

Carrier

- Grind Matic RH4 — bit grinder
- Programmable blast horn
- Central Lubrication System (CLS)
- Diesel-driven engine heater
- Electric fuel-filling system
- Hydraulic winch
- Track gear cover
- Jump start

Hole and inclination systems

- GPS compass aiming unit
- GNSS compasses for aiming, height control and hole logging
- Hole navigation system with remote display

Additional options

- Spare radio transmitter (radio remote control)
- Water mist system with 150 L tank and hydraulic pump
- Extra light kit
- Hydraulic AUX outlet
- Bag handling system for DCT

Additional options - not mounted

- Basic toolkit
- First 50 hrs service kit for compressor
- Gas charging equipment for rock drill
- Lubrication kit
- Belt for radio remote control (RRC)/OU
- Parts book – hard copy
- TAC bushings

9868 0365 01, 2025-01 Orebro, Sweden. Legal Notice © Copyright, 2025. Epiroc Rock Drills AB, Orebro, Sweden. All product names in this publication are trademarks of Epiroc. Any unauthorized use or copying of the contents or any part thereof is prohibited. Illustrations and photos may show equipment with optional extras. No warranty is made regarding specifications or otherwise. Specifications and equipment are subject to change without notice. Consult your Epiroc Customer Center for specific information.

United in performance. Inspired by innovation.

Performance unites us, innovation inspires us, and commitment drives us to keep moving forward. Count on Epiroc to deliver the solutions you need to succeed today and the technology to lead tomorrow.
epiroc.com

