

# ***DEEPHOLE DRILLING***

In the water well, oil & gas, geothermal and exploration markets

FIRST EDITION 2015

*Atlas Copco*



# THE ATLAS COPCO ADVANTAGE

Atlas Copco's Predator is the epitome of efficiency, safety and mobility. The API 4F licensed Predator features 220,000 lbs of hookload on an extremely mobile platform. Greater automation and hands-free pipe handling contribute to a safer working environment.

[www.atlascopco.com/predator](http://www.atlascopco.com/predator)

*Atlas Copco*





# Contents

## Foreword

- 2 Foreword by Jaco van der Merwe

## Talking technically

- 3 Evolution of well drilling  
7 Deephole directional drilling  
9 State-of-the-art well drilling technology  
13 Knowing when to use DTH or rotary drilling technique  
19 Tool selection  
21 Ergonomics and safety  
23 Pipe loader increases safety  
25 Predator™ drilling system

## Case studies

- 27 Going after the hard stuff  
29 XC is for 'Extra Capabilities'  
31 Nature's building blocks  
33 Oil and gas drillers turn to 'mixed fleet' approach  
35 Tapping into a hot market  
37 Carizzo Sands—too loose to walk on but not to drill  
39 Clean water for Panama  
41 The antidote for arsenic  
43 Best bit for the job  
45 Diamonds in the rough  
47 Draining saturated ground  
49 Core drilling with an Atlas Copco TH60DH  
51 The Water Below  
55 Exploring Chile's Norte Grande region  
with Atlas Copco's RD10+  
57 Designing a versatile water well rig  
61 Star of India

## Product specifications

- 64 Well drilling rigs  
82 Secoroc Klaw Bits  
88 Secoroc Rock Drilling Tools  
122 DRILLCare  
124 Service  
128 Where to find us

For latest updates contact your local Atlas Copco Customer Center or refer to [wwdrills](http://wwdrills) or [www.atlascopco.com/oilandgas](http://www.atlascopco.com/oilandgas)



**Produced by:** Atlas Copco Drilling Solutions LLC, PO Box 462288, Garland, TX 75046, USA, Phone +1 972 496 7400.

**Publisher:** Justin Cocchiola, [Justin.Cocchiola@us.atlascopco.com](mailto:Justin.Cocchiola@us.atlascopco.com)

**Editing team:** Justin Cocchiola, Alex Grant, Shane Lein

**Adviser:** Alex Grant, [Alex.Grant@us.atlascopco.com](mailto:Alex.Grant@us.atlascopco.com)

**Contributors:** Alex Grant, Jaco van der Merwe, Shane Lein, Justin Cocchiola, Tom Moffit, Ray Kranzusch, Josh Marcus, Curtis Larson, Jason Palmer, Alf Stenqvist, Graeme Mckenzie, Pavel Vedenev, Mike Millsaps all [name.surname@country.code.atlascopco.com](mailto:all.name.surname@country.code.atlascopco.com)  
Holly Wilson, Scott Ellenbecker, Joseph Bradfield, Sara Schmuck.

Digital copy of Atlas Copco reference edition can be downloaded at [www.atlascopco.com/wwdrills](http://www.atlascopco.com/wwdrills) and [www.atlascopco.com/oilandgas](http://www.atlascopco.com/oilandgas).  
Reproduction of individual articles only by agreement with the publisher.

**Layout:** Rafaella Turander, [ahrt.informationsdesign](mailto:ahrt.informationsdesign), Örebro, Sweden, [turander@ahrt.se](mailto:turander@ahrt.se)

**Printed by:** TigerPress, East Longmeadow, MA, [www.tigerpress.com](http://www.tigerpress.com)

### Legal notice

© Copyright 2015, Atlas Copco Drilling Solutions LLC, Garland, Texas, USA. All rights reserved. Atlas Copco is committed to comply or exceed all applicable laws, rules and regulations. Photos in this publication may show situations which complies with such laws, rules and regulations in the country where the photo has been taken but not necessarily in other parts of the world. In any case think safety first and always use proper ear, eye, head and other protection to minimize risk of personal injury. This publication, as well as specifications and equipment, is subject to change without notice. All Atlas Copco product names (including but not limited to Predator, COPROD, TEAMALLOY, COP and Secoroc) are registered trademarks or trademarks of one or more Atlas Copco Group companies.

“  
With a product range saturating the water well and oil and gas markets, we plan to use this tool to develop our business and offer training for our employees and customers around the world  
”

# Foreword

We at Atlas Copco are excited to present to you our first reference book for our deephole market in the water well, oil and gas, and geothermal industries. We define deephole as drilling to depths ranging from about 300 to 10,000 feet. With a product range saturating the water well and oil and gas markets, we plan to use this tool to develop our business and offer training for our employees and customers around the world.

Atlas Copco was founded in 1873, and has always had innovation at the core of its identity. In 1972, nearly 100 years after the company was founded, Atlas Copco began producing rigs for drilling gas and CBM wells. Now, as we flash forward to 2014, Atlas Copco has produced over 1,000 deephole drills for the water well and oil and gas industry within the last two decades. Customer interaction, training, new product development and increasing manufacturing capacity are all important factors to help us grow. We continue to improve and develop our current product portfolio that includes our water well product line, RD20 product line, as well as the newest addition to our oil and gas product line: the Predator Drilling System.

New product development is always first in mind at Atlas Copco, and it's something that we will divert great attention to in years to come. Whether it's improving our current fleet or looking into different solutions to help our customers, our engineering and marketing team has been working to better understand our target markets. Our teams have been traveling around the world to meet our key customers and sales companies to discuss their needs and wants in the oil and gas, water well, geothermal, and exploration markets. In an ever-changing environment, we at Atlas Copco are working to adapt and grow with the changes our deephole customers face. We will continue to strive to offer the best products for our customers, and carry on with educating our employees and customers on our product offerings.

We're excited about the possible synergies we can extract from the larger Atlas Copco organization, specifically with our colleagues involved with rock drilling tools, compressors, and rental. You will see those synergies come together in this book, and we will continue to contact our key customers and sales companies around the world to discuss the deephole business. We encourage feedback from our production and maintenance personnel who work with our rigs to help guide our improvements, and hope to be able to share our mutual success stories in future editions of our Deephole Well Drilling reference guide.

We hope you enjoy the first edition.



**Jaco van der Merwe**

*Vice President Marketing – Deephole Drills  
Atlas Copco Drilling Solutions LLC  
jaco.vdm@us.atlascopco.com*





# Evolution of well drilling

## The need for energy inspired the modern innovations that replaced shovels as water well tools

Western Civilization relied on digging techniques to construct their wells until the nineteenth century. Since then, the ever-increasing need for hydrocarbon-based fuel sources has rapidly driven innovations in technology and technique to make almost any resource accessible to the modern driller.

Today's well drilling practices can be traced back to the copper digging tools of early civilization, though their evolution was not at all a steady progression. It began with the search for water.

## Earliest documented wells

Archeologists discovered the earliest known man-made watering hole in the well-preserved Neolithic community of Atlit Yam, off the coast of Israel. Found submerged 30 feet (10 m) underwater in the Mediterranean's sandy seafloor, the site features a stone water well dug to 18 feet (5.5 meters). The 9,000-year-old well is the oldest ancestor of record for all wells today.

By 2000 BC the Persians had devised underground water collection and conveyance tunnels called *qanat*. The qanat protected the water from high surface evaporation rates, making it possible to sustain populations in arid regions.

From a contemporary perspective, the qanat might be considered the ancient predecessor of the production lateral. Long, slightly graded tunnels began beneath the water table on one end. Water seeping into the tunnel was

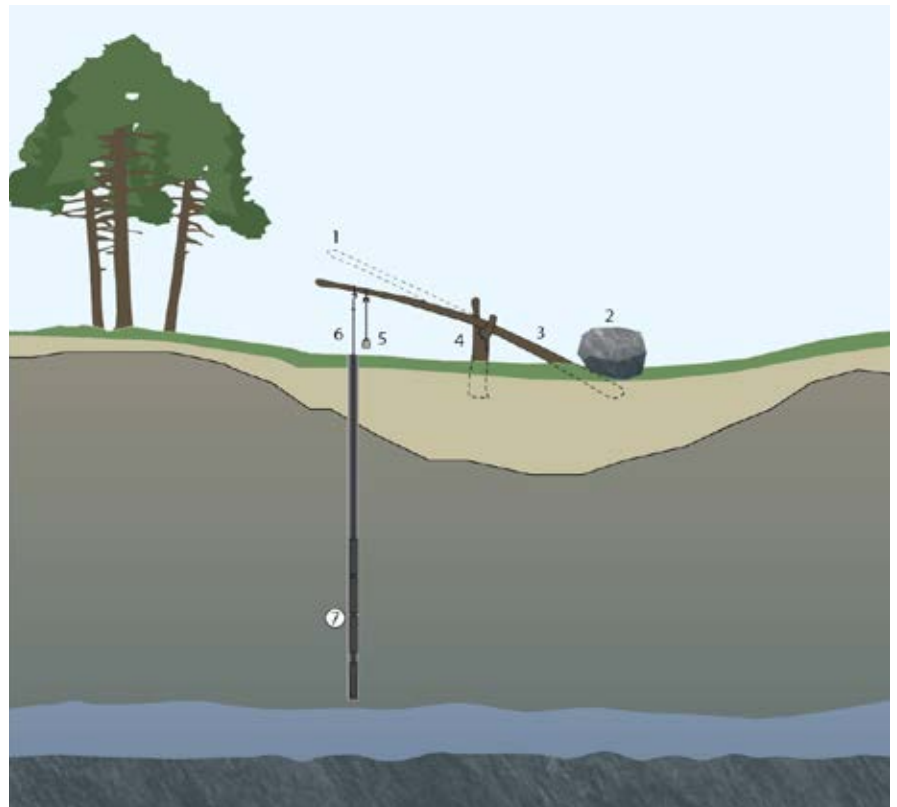

Earliest springpole drill design from which modern rotary and percussion drill rigs evolved had these basic components: (1) pole (shown in return position); (2) anchor; (3) springpole (shown during impact stroke); (4) fulcrum; (5) stirrup; (6) rope; (7) cutting tools.

led to destinations such as cropland. Vertical shafts created along the tunnel's path during its construction could be used later to access drinking water. This technique was imitated throughout Arabia and into Europe, Africa and Asia.

## Predecessors to cable rigs

About this same time, China developed an effective percussion drilling technique. Heavy chiseling and crushing tools suspended from bamboo frameworks were dropped repeatedly into a hole. The ancient drillers successfully used this method to drill to 3,000 feet (900 m) vertical depth. The design demonstrates the fundamental operating principle of modern cable drilling rigs.

Digging remained the chief form of well making in the West until the 1800s. A percussion-based drilling

system called the spring pole method was first documented in 1806 for a brine well by salt manufacturers David and Joseph Ruffner. The brothers suspended a steel cutting tool from a rope attached to a small, springy tree trunk. Its base secured in the ground, the trunk was propped over a fulcrum to position its tip over the hole. Stirrups tied to the tip allowed the Ruffners to drop the tool in the hole by kicking downward. The spring pole returned the tool upward for the next kick.

Using this simple reciprocation drilling technique, the Ruffners completed a 58-foot-deep (17.7 m) well in about 18 months, advancing more than 40 feet (12 m) of the well through bedrock.

Various mechanisms were added to the Ruffners' spring pole drill design to turn the bit for more efficient drilling and to mechanize reciprocation. A competing percussion system called



Broad and side views of seven styles of spring pole bits. The first two pairs of images on the left are two rock bits for quarrying. The remainder are a range of bit shapes created for various ground conditions by drilling pioneers such as David and Joseph Ruffner, Billy Morris and Levi Disbrow.

the walking beam drill developed at about the same time. Like the Chinese system, the spring pole and walking beam designs are forerunners of modern cable rigs still in use today. For decades these designs were used only by salt drillers, who would often strike oil and gas looking for brine.

This incidental gas was sometimes used to fuel the salt production furnaces. In 1859 Edwin L. Drake drilled the first well dedicated to petroleum production. The successful 69-½ foot (21.2 m) well is celebrated as the beginning of the petroleum industry.

## Advent of rotary drilling for oil

The earliest example of rotary drilling dates 5,000 years ago to an Egyptian quarry. Holes in stone progressed inches at a time to depths as great as 20 feet (6 m) using hollow rods rotated over ground gems and, later, diamonds. However, it was Howard Hughes Sr.'s 1908 patent for a dual roller cone drill bit incorporating a new alloy known as tungsten carbide into the cutting surface that revolutionized the rotary drilling industry.

Only drillers using tungsten carbide roller cone bits could stay competitive in the petroleum industry. When the patent expired in 1951, additional manufacturers contributed to bit design.

## Drilling fluid history

In the late 1880s drilling engineers discovered the advantages of using an oil-based mud. The mud coated the well bore, which helped maintain hole walls. The technique was proven in a well that encountered wet sand. Switching to “mud” sealed the bore, allowing drilling to continue to completion.

Mud drilling technique was used in the famous Spindle Top strike, the prolific well that established the U.S. as the world’s oil-production leader at that time. Water-based “mud” was created with natural additives such as bentonite clay, which caked the bore and floated cuttings, and barite, which increased drilling fluid weight to counter formation pressure and control influx.

Though the word mud is still widely used, the more accurate term today is drilling fluid, since drillers have a wide variety of synthetic additives to choose from. These include emulsifiers, degreasers, shale stabilizers, alkalinity controllers and corrosion inhibitors. Other additives address lost circulation, adjust viscosity or increase lubricity.

Modern drillers switch fluids as they encounter varying conditions in the formation, or as they perform different well-drilling tasks such as “sweeping the well.” A sweep drilling fluid is formulated to clean a hole of sludge to

reestablish efficient drilling performance or to prepare a dirty hole for casing.

## Pneumatic percussion

Pneumatically powered rock hammers have been in use since the mid-1800s, mimicking the action of manual drilling by striking a chisel into rock. Tool and bit designs have since been improved. The invention of carbide button bit insert designs significantly improved cutting performance. Until the advent of the down-the-hole (DTH) pneumatic hammers, use of pneumatic percussion by top hammer drills was reserved for relatively short holes of smaller diameter. Locating the hammer at the bit (“down the hole”) instead of the top of a drill string eliminated energy transfer inefficiencies caused by an increasing mass of drill steel and number of joints as a deephole progressed. Exhaust from the hammer flushes the hole of chips.

DTH drilling offers several advantages over rotary technique. In hard rock conditions, DTH can offer penetration rates at least five times faster than rotary. Pneumatic tools require less weight-on-bit, permitting the use of lighter rigs with faster setup and takedown times. Cutting force is supplied by reciprocation, not rotation. Less deflection as the bit encounters variations in the formation means holes are drilled more precisely.

## DTH directional drilling

The use of DTH in well drilling had been solely for forming accurate, vertical bores. Rotary was considered the only technique to use for “turning the hole” until 2012, when directional drilling crews in the Marcellus Shale region of the United States successfully began using the newly patented Atlas Copco directional DTH system to steer percussive drilling.

Use of directional DTH in place of directional rotary technique to drill the upper portions of a production well and set surface casing has allowed wells to be completed at twice the speed and half the cost. The directional system was introduced to the market for Atlas



Copco's complete line of DTH hammers in 2013.

## PDC bits

Because DTH cannot use weighted drilling fluid to keep the bore at higher pressure than the formation, it is referred to as an under balanced drilling technique. As much as 70 percent of deephole drilling requires over balanced drilling with weighted drilling fluid to control formation influx, maintain bore integrity, or both. In such formations, however, tricone bits are being replaced with another rotary tool innovation first introduced by Hughes Tool Company in 1971: polycrystalline diamond compact (PDC) bits. New Tech Drilling Products was one of the leaders of improved PDC technology that overcame some of the early problems drillers encountered with disc fractures and delamination. Atlas Copco acquired New Tech Drilling Products in August, 2012, to give the product line a global distribution and support network that makes the products available to well drillers worldwide.

Unlike DTH bits and tricone bits, PDC discs in the bit's turbine-like blades cut by shearing material from the hole bottom. They provide a much more aggressive rate of penetration than roller cones. Like roller cones, PDC bits can also be used for air rotary technique.

## Ecology and well design

The primary concerns at the time of the 1901 Spindle Top gusher were likely damage from the ensuing fire and revenue lost to irrecoverable crude oil, which was spewing uncontrollably at a rate of up to 100,000 barrels a day. Damage done to farmland and surface structures was easily comprehended, but the industry was new; environmental impact was not fully understood.

Ecology and environmental policy have been improving with every advancement in drilling application. Today's deephole drilling engineers design wells that do not allow drilling fluids to enter water aquifers from their well bores, nor brine, heavy metals or radioactive materials to use their bores as a pathway to travel up to the aquifer.

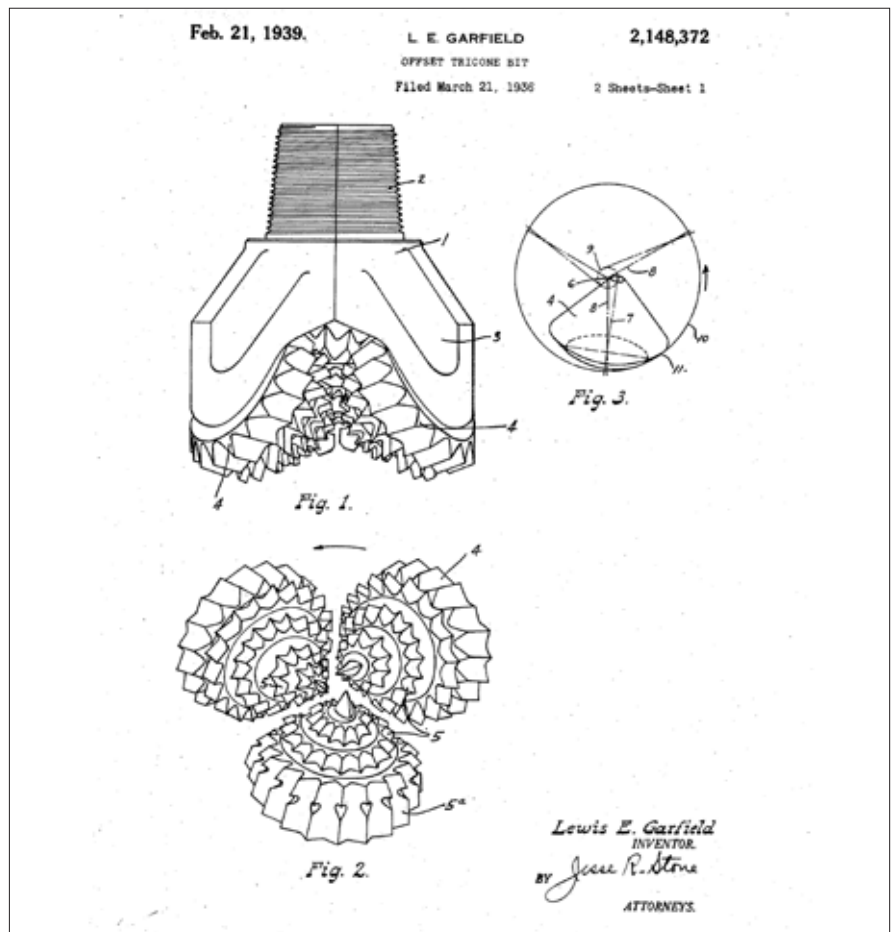

*Howard Hughes Sr.'s 1908 patent for a dual roller cone drill bit incorporating a new alloy known as tungsten carbide revolutionized the rotary drilling industry. Instead of scraping the rock, the two conical cutters of the Hughes bit chipped, crushed and powdered hard-rock formations to reach vast amounts of oil in reservoirs thousands of feet below the surface.*

Statutes governing well design vary by jurisdiction, but almost all of them prescribe the use of surface casing to a depth well beyond water-bearing structures. The area between the surface casing and bore wall are sealed with grout. This work is often assigned to "top hole" contractors and to grouting specialists, especially for wells created for unconventional resource recovery.

Hydrocarbon recovery from unconventional reservoirs most often requires drilling to vertical depths thousands of feet below the surface. From a kickoff point, production laterals are drilled horizontally thousands of feet more, exposing as much bore to the thin low-porosity, low-permeability production zone as feasible. These wells, including their laterals, are cased to total depth. To increase permeability, each lateral is sectioned off for hydraulic fracturing. Under great pressure, water is forced

into a packed off section of pierced lateral casing to open any existing fissure in the formation and to create additional openings, forcing sand into them and increasing recovery volume. Fracturing crews collect fluid as it returns from the formation. They take the fluid for filtering and treatment. Once treated, it is reused.

Society always placed value on its most essential resources. Though design and research race to keep up with the ever-increasing global demand for energy, the history of well drilling begins and ends with a focus on water.

**Alex Grant**  
Product Line Manager  
for Well Drilling

**Joe Bradfield**







# Deephole directional drilling

## Precision control of wellbore trajectory is now possible by both rotary fluid and DTH pneumatic percussion tools

Being able to “turn a hole” was first used to make holes straighter. Modern directional drilling specialists routinely steer drilling tools to maximize production potential, reach otherwise inaccessible or impractical reservoirs, and intercept bores to regain control of blowouts.



The driller is watching the angle that the mud motor is taking, indicated by the light on the dial. This particular job is drilling 240 degrees southwest.

Controlling the direction of a well bore initially began with attempts to correct deviation, keeping the well straight. Straight drilling hit the intended target accurately and with the fewest drill feet. Though directional control has been available since the 1920s, equipment that permitted uninterrupted progress was not available until the latter part of the 20th century.

Today, precise control of bore direction with both rotary and percussion techniques gives producers a number of well design advantages. It allows drillers to sidetrack a bore that cannot be drilled to completion due to hole obstructions or geology concerns. Multiple wells can be drilled from a single location. Targets beneath inaccessible surface locations, such as those under cities, lakes and rivers or difficult terrain, can be accessed laterally even from miles away.

Using directional drilling techniques, well designs can maximize exposure of the production bores to the reservoir, a particularly useful technique in unconventional resource recovery. Multiple wells can be drilled on a single pad in close proximity, whose bores fan away from each other to

prevent interference. Production from multiple, isolated reservoirs can be connected at their most favorable stratigraphic points by production laterals from a single well location rather than by multiple wells. If formation pressure overcomes a well (a situation known as a “blowout”), the well can be intercepted with pressure relief bores for injecting heavy fluids to “kill the well.”

## Directional motors

Although other techniques exist for steering progress of the drill string, the most commonly used device in deephole drilling is the directional motor. A directional motor consists of a progressive cavity pump whose body is slightly bent or curved. It is placed at the bottom of drill string near the bit. While the drill string is rotating, the motor’s angle of longitudinal curve is shared equally by every degree of rotation, and drilling continues in straight line.

When drill string rotation is stopped, drilling will progress in the direction of the motor’s angle. The motor’s

corkscrew-like internal rotor and cavity, driven by drilling fluid or compressed air, causes the bit to continue rotating, and therefore cutting, even while the drill string’s rotation is stopped. Directional motors used with drilling fluid are referred to colloquially as mud motors.

## Measure-while-drilling tools

Drillers use measure-while-drilling (MWD) tools to know precisely where the drill string is progressing. MWD operators are typically engineering specialists who provide directional drillers the data required to keep the well accurately on the planned trajectory.

MWD equipment uses accelerometers to measure wellbore inclination from vertical and magnetometers to determine azimuth to provide a three-dimensional plot of drilling progress. Additional sensors may be used to measure other data such as rock formation density, porosity and pressure.

The sensors send their data to the surface using “mud pulse telemetry.”

Power for these transmissions may be generated by turbines in the fluid flow, by lithium batteries or by a combination of both.

## DTH directional drilling

In 2012 a directional drilling system for down-the-hole (DTH) pneumatic percussion drilling tools patented by Atlas Copco was successfully used by directional drillers throughout the gas plays of Appalachia in the United States.

Atlas Copco based the directional system on existing technology, overcoming engineering challenges with modifications in design. The directional motor's bit box was shortened to accommodate, in part, the addition of the hammer placed between the motor and bit.

The blow-down sequence of the hammer was carefully adjusted to prevent over-rotation of the hammer when it was lifted off the bottom. Flow rate now remains the same whether the hammer is on the bottom or off, preventing over-rotation of the motor and damage to the electronic measuring-while-drilling equipment. Jet subs placed along the drill string redirected air flow away from the bottom hole assembly to assist in chip removal up the annulus. A hydrocyclone managed fluids used to control hole integrity.

## Use in Appalachia

Increasing the amount of vertical well profile that can be completed by DTH tools is highly advantageous to producers. In the Appalachian region it permitted well completion in half the time at half the cost.

Until the introduction of directional DTH, drillers were tripping out after casing the vertical portion of the well. They converted to rotary, with drilling fluid necessary to power mud motors and used measure-while-drilling tools to move bores away from each other as is specified for collision avoidance on most wells with deep vertical profiles. Using DTH, however, drillers were able to turn 2- to 4-degree curves and drill a well's tangent, or "nudge" section, up to 30 degrees or greater. Rotary nudging



*Left: This job was performed with an Atlas Copco RD20 using mud to drill directionally. It called for a large shaker box (on the right) and two large mud pumps to deliver clean mud to drive the directional mud motor. Right: This air motor used for directional drilling looks the same as a mud motor. This particular motor was used in a job requiring a bend of 1.25 degrees.*

in one area had typically progressed at 30 to 40 feet per hour. DTH nudging in the same area averaged three hundred feet an hour.

Directional control of trajectory is done much the same as for rotary technique, but progress is much faster. In the Appalachian plays, drillers typically started a surface hole with a 12-inch hammer to drill 17 1/2-inch bores, lining these with 13 3/8-inch casing. Then they completed the vertical by sending down the 12-inch tool again with a 12 3/8-inch or 12 1/4-inch bit. This was lined with 9 5/8-inch casing to a sort of initial kick-off point.

Instead of switching to rotary technique at this point, drillers set up a directional tool assembly with 8 3/4-inch tool to nudge the hole to its primary kickoff point at 5,600 to 6,000 feet. At that point drillers switched to rotary and drilling fluid for overbalanced drilling to total depth. The number of days to drill 12,000-foot (3,658 m) holes here start to finish had been nearly 30 with conventional rotary techniques.

But since the surface to kickoff portion of the well was completed in just six days, the well was completed in only 13. Directional hammer drilling saved the company more than half the time and half the cost of rotary.

## Evolving potential

Directional drilling capability was extended to the full line of Atlas Copco DTH hammers in 2013.

As of early 2014 DTH directional assemblies had been completing turns of 2 to 4 degrees with one contractor demonstrating turns of up to 6 degrees. DTH directional applications are still being explored, such as drilling production laterals in sandstones and dolomitic limestone. The technique is still evolving.

**Alex Grant**

Product Line Manager  
Well Drilling



# State-of-the-art well drilling technology

## Atlas Copco innovations keep drillers competitive

Atlas Copco cannot control the price of oil and gas, they can provide drillers with improved technology to meet their customer's goals economically. Deephole techniques and tools are in constant evolution, and Atlas Copco innovations have helped to set the pace.

A deephole driller's goal is maximum productivity. Atlas Copco innovations increase machine availability and extend tool life to keep today's drillers drilling for water, coal-bed methane, oil and natural gas.

## State of the art DTH

Atlas Copco introduced the deephole drilling industry to directional drilling with down-the-hole (DTH) pneumatic percussion technique. The achievement did not come from exotic new innovations but design modifications of existing tools, meaning that complementary products such as the EDGE drill monitoring system, jet subs, hydrocyclone and various consumables that were already in place to support the new directional system's primary components.

### EDGE

Atlas Copco introduced its EDGE drill monitoring system for deephole DTH. The EDGE system consists of a sensor, a data capture and processing unit and a PC with a 7-inch (180 mm) screen. It can be fitted to any deephole rig using Secoroc DTH hammers.

The sensor "reads" drill string vibration, translating it with software into digital and graphic data. Drillers see bit performance data in real time on a



The EDGE drill monitoring system "reads" drill string vibration, showing performance data on a display at the driller's station. This real-time information allows the driller to constantly monitor drilling conditions in the hole and make adjustments as needed.

display mounted at the driller's station for immediate interpretation, though the bit is thousands of feet away.

Instantaneous feedback allows the driller to continuously optimize bit performance through weight on bit and rotation. Improved drilling efficiency translates directly into optimum penetration rates that yield more footage over the life of the bit, greater fuel economy, less heat-generating vibration, reduced stress on hydraulics and extended life from secondary compressors or boosters. Real-time monitoring of conditions at the bottom of the hole means sudden changes in formation conditions such as a sudden influx of water; a flushing problem or change in rock hardness can be resolved before they cause costly production delays or damage.

### Hydrocyclone

The Atlas Copco Secoroc hydrocyclone keeps the hammer dry when fluids are injected to maintain the hole. It allows fluids to treat the hole before they are

ejected back up the column. They do not reach the hammer.

### Jet sub

Jet subs allow large volumes of air to be sent down the drill string for flushing, channeling no more to the hammer than is needed for efficient operation. Multiple jet subs placed throughout the drill string allow excess air at various points to assist evacuation in the drill bore. This is especially important at points in the turn or horizontal drilling situations. Use of jet subs also prevents over-pressuring of the hammer environment in deep, wet or soft rock applications.

### Secoroc one-piece retrieval systems

The Secoroc one-piece retrieval system simplifies and improves bit retrieval. The system is comprised of a dual four-lug mechanism on the retrieval sleeve that corresponds to grooves in the bit head. Once the lugs and grooves are



Left: Secoroc QLX 60: The various innovations and improvements featured in the QLX 60 OG DTH hammer can increase penetration rates as much as 20 percent.

aligned, the driller rotates the sleeve to secure it in position. The one-piece system is available in shank types Q6, Q8, T9 and Q12, with two types of retrieval sleep sleeves to accommodate Atlas Copco Secoroc QL/TD 80 and TD 85/90 hammers. Current QL and TD hammers can be converted to the bit retrieval system with a change of the chuck body.

### Hammer improvements for deephole applications

The QLX 60 OG DTH hammer designed for the oil and gas (OG) industry represents several design improvements that increase penetration rates up to 20 percent. One is a new Air Select System that allows the hammer to use more air rather than strain air compressors to force air through it. Another is the radial alignment of the air select guide to the casing inner diameter.

### Air compressors, boosters

Since Atlas Copco's first DrillAir high-pressure compressor came out, its portable air fleet options have continued to evolve. The large-volume, high-pressure models of the Atlas Copco TwinAir and DrillAir series support the enormous delivery requirements of deephole drilling on air.

TwinAir units yield the highest volume of compressed air per square foot. The TwinAir XRV 2000, for example, delivers up to 1,975 cfm (936 L/s) of compressed air at 365 psi (25 bar).

The Atlas Copco DrillAir screw element in the DrillAir series provides the highest air volume at some of the highest air pressures in the industry.

For instance, the DrillAir XRXS 1240 and XRXS 1275 can maintain 1,198 cfm (566 L/s) and 1,252 cfm (591 L/s) at 435 psi (30 bar). The XRYs 1260 can deliver 1,207 cfm (570 L/s)

of compressed air at 510 psi (35 bar). Atlas Copco has a wide range of Hurricane Boosters that can be used with these compressors. Units like the B27-122/2320 provide up to 3,650 cfm (104 m<sup>3</sup>/min.) at up to 2,320 psi (160 bar). High pressure models such as the B9-64/5000 can deliver 750 cfm (21 m<sup>3</sup>/min.) at 5,000 psi (345 bar). The economy and efficiency of drilling with these air packages can be increased with several high-tech options. The Atlas Copco FuelXpert regulation system option regulates engine speed and air inlet to optimize fuel consumption to load and working conditions.

Oiltronix electronic controlled oil temperature system prevents condensation while drilling in hot and humid climates. COSMOS controllers allow remote monitoring of the units via Internet or mobile phone network data service.





Top left: These “Dirt Digger” PDC bits feature polycrystalline diamond compact inserts on the bit’s blades to cut and ream a hole by shearing material away. Top right: The cutters on a Klaw bit are placed at specific locations to attack angles for maximum formation removal. Bottom left: The hydrocyclone keeps fluids from reaching the hammer. Bottom right: Jet subs prevent over-pressuring of the hammer in certain applications.

## ROTARY TOOLS

### Polycrystalline diamond compact (PDC) bits

One of the greatest advancements in rotary drilling has been the introduction of durable PDC bits. Unlike roller cone and DTH bits which crush rock, polycrystalline diamond compact inserts on the bit’s blades cut and ream a hole by shearing material away. PDC bits can be used with either air or drilling fluid for flushing.

NewTech Drilling Products was one of the leaders in successfully overcoming design limitations encountered by early manufacturers such as disk fracturing and delamination. Atlas Copco acquired NewTech Drilling Products in 2012, making its PDC and Klaw bit lines available to customers worldwide through its global distribution and product support network.

The PDC inserts are synthetic diamond disks about  $\frac{1}{8}$  inch (3 mm) thick and about  $\frac{1}{2}$  to  $\frac{3}{4}$  inch (13 to 19 mm) in diameter. The bits are available in either a 4140 alloy steel or cast infiltrated tungsten carbide matrix body, in diameters ranging from 7 $\frac{1}{8}$  to 36 inches (200 to 914 mm) for the steel body bits and 5 $\frac{7}{8}$  to 17 $\frac{1}{2}$  inches (149 to 445 mm) for matrix body bits.

### DEEPTHOLE HYDRAULIC TOP DRIVE RIGS

Atlas Copco’s hydraulic top drive rigs support both rotary fluid and DTH technique. deephole versions of the T3W, TH60 and T4W drilling rigs with 70,000 lbf pullback capability are designated DH.

The RD20 XC (120,000 lbf / 533 kN pullback) and the Predator Drilling System (220,000 lbf / 978 kN pullback)

are specifically designed for the oil and gas industry. All five models can be used for top hole drilling and case setting in “mixed fleet” well development technique. The RD20 XC and Predator Drilling System can also be used alone to complete wells in shallow oil and gas applications. True hands-free pipe handling is provided as an integral part of the Predator Drilling System. An automated pipe loading system is also available for the RD20, the RD20 APL.

#### Alf Stenqvist

VP of Marketing  
Rock Drilling Tools

#### Alex Grant

Product Line Manager  
Well Drilling

Joe Bradfield





# Knowing when to use DTH or rotary drilling technique

**Productive contractors use both DTH and rotary techniques. The formation tells them which to use.**

As a general rule, the harder the rock in the formation, the more economical down-the-hole (DTH) pneumatic percussion becomes. Yet there are times when rotary is the most productive, or the only feasible, option. While modern innovations in tooling and technique improve the capacity of each method of drilling, the choice always comes back to economics: the one that increases overall profitability for the contractor and the customer on a given job.

For decades it has been common knowledge that the pneumatic down-the-hole (DTH) hammer drilling technique is generally two to five times faster than rotary techniques in rock. Now that DTH has evolved to the point where it can be used to build a shallow curve and hold inclination, the amount of well profile that can be drilled with DTH is no longer restricted to the straight, vertical surface section. Where DTH drilling is possible, economics often make it a preferred technique.

However, about 70 percent of Deep-hole oil and gas applications (exceeding 1,000 f/300 m) are in formations that require overbalanced drilling technique. Overbalanced drilling relies on a column of drilling fluid to control gas influx and/or maintain bore wall integrity. To date, holes requiring overbalanced drilling rule out the use of DTH and air rotary.



Deephole DTH drillers who use the EDGE drill monitoring system receive feedback directly from formation through the bit and drill string. The ability to make instantaneous adjustments optimizes ROP and extends tool life, meaning fewer trips out of the hole to change bits and less wear on BHA components.

Knowing the basics of each type of drilling, DTH and rotary, and becoming familiar with the recent innovations for both methods will help a driller know when to use which. The question, “Which is more economical?” is no longer an either/or question. The correct answer is: both are equally economical.

The entire deephole line of Atlas Copco truck-mounted top drive drilling rigs are capable of both DTH and rotary drilling. Atlas Copco water well rig models also come in deephole versions noted with DH in their model name: T3WDH, TH60DH and T4WDH. The Atlas Copco RD20 XC is designed with added oil and gas drilling capabilities. And the Predator Drilling System was designed specifically for oil and gas drilling.

## Rotary and DTH mechanics

Rotary and DTH drilling actually have a lot in common. They both incorporate fundamental improvements on early drilling techniques, such as simultaneous cuttings removal enabling continuous drilling. Both have the ability to drill extremely hard materials. Both involve rotation to move a bit, as well as to make up and break out joints in drill pipe or casing.

The mechanism for turning the drill string, called a drive, varies with the type of rig. It may be a rotary table in the deck of the rig or a hydraulic mechanism with the feed system, traveling down the mast as drilling or case-setting progresses or returning upward as pipe or casing is tripped out.





The downward force necessary for optimum bit performance depends on the size of the tooling and the increasing weight of the drill string as the hole advances.

The top drive not only supplies torque to turn the drill pipe but also applies downward force (called pulldown) or upward force to lift against the weight of the drill string (pullback). The downward force necessary for optimum bit performance depends on the size of the tooling and the increasing weight of the drill string as the hole advances.

Although DTH requires less pull-down than rotary to start a hole, large

diameter hammers do require enough weight on bit (WOB) to enable sufficient energy transfer to the formation. Insufficient WOB allows the bit to return the energy to the hammer, lowering productivity and inflicting excessive vibration on everything in the tool string to the top drive.

As the hole progresses, the weight of the drill pipe, collars and other tooling on the drill string must be factored

based on specifications or need for that formation and hole diameter. Their mass increases to a point at which the driller must hold back to counter excessive WOB.

Pullback is the rig's capacity for holding back excessive weight of the drill string while drilling. Pullback, or hook load, determines the depth that a hole may be drilled to, since at no point may the weight of the drill string exceed the rig's ability to pull it back up the hole, a process referred to as tripping out.

### How DTH and rotary cut formation material

DTH bits consist of a tungsten carbide metal body whose shank splines and connection match a specific hammer connection system such as QL120 or TD100. The carbide buttons on its face and in its gage row cut and ream the hole. Each button transfers its share of impact force into the rock, causing micro-fractures in the rock, which breaks away in chips.

Rotary drillers rely on several kinds of bits. Among the most common are roller cones, drag bits and PDC bits. While all three types of bits rotate with the drill string, the roller cone, like the DTH bit, relies on the carbide buttons to create chips. The canted wheel of each roller transfers WOB to the material at the hole's bottom, causing it to fracture and chip away.

Drag bits are one-piece steel bit bodies with wing-like blades. The edge of the forward part of the bit scrapes

### Truck-mounted deep-hole drill rigs



	Predator	RD20	T4W DH	TH60 DH	T3W DH
Pullback lbf (kN)	220,000 (978)	120,000 (533)	70,000 (311)	70,000 (311)	70,000 (311)
Pulldown lbf (kN)	50,000 (220)	30,000 (60.5)	30,000 (133)	30,000 (133)	30,000 (133)
Air package cfm/psi (lps/bar)	Offboard	1250/350 (590/24)	1250/350 (590/24)	1070/350 (505/24)	1070/350 (505/24)
Max. torque lbf-ft (kNm)	30,000 (40.7)	8000 (10.8)	8000 (10.8)	8000 (10.8)	8000 (10.8)

Atlas Copco's line of truck-mounted deephole drill rigs mobilize quickly and require smaller crews. They excel at both water well and oil and gas applications. The Predator and RD20 are used to drill and set casing for the top portion of oil and gas wells ahead of conventional rigs that will complete them to total depth. They can also be used to complete shallow wells.



against the bottom of the hole, deepening it. The edges at the side of the bit ream the hole, acting as gages. PDC bits are one of the most widely used bit types due to both their more aggressive rates of penetration (ROP). PDC bits consist of a solid turbine-like body of steel or tungsten carbide matrix blades. The faces of its blades are imbedded with disks of diamond-impregnated metal. Like the drag bit, a PDC bit's front disks shear the bottom of the hole while the side disks, or gages, ream the diameter.

## Drilling on air

Cuttings management is a formidable task in deephole drilling, with several thousand feet of cuttings and fines to lift up and out of the hole. It is either managed by compressed air, drilling fluid, or both. Being able to drill on air has several advantages. Air does not need to be sourced and hauled to a site, as fluid does. It does not need to be recovered, treated and disposed of. It has no cost other than the acquisition, maintenance and fueling of equipment to control it. In formations with lost circulation, it might also be the only choice.

In rotary air technique, compressed air has one primary job: flushing. The compressed air channeled through the bit keeps the bit clean and flushes debris from the hole so the bit always contacts fresh surface to fracture or shear, depending on bit type. As the hole's depth increases, though, so does the mass of cuttings in the bore's column. The air must be sufficient to overcome that mass. In holes that encounter water in the formation, the air must also overcome this added weight.

In DTH drilling, compressed air raises the cuttings but also operates the hammer. For the DTH driller, this is an additional parameter to balance. The mass of cuttings, and any water that may be present, increasingly compresses air at the bottom of the hole and causes back pressure in the hammer's environment. As back pressure increases, differential pressure across the hammer decreases. This loss of differential pressure means less energy is available for the piston to transfer

through the bit during impacts. A DTH driller must add air for effective flushing without over-pressurizing the hammer or its immediate environment. Atlas Copco Secoroc has hammer designs such as the TD, QL, and QLX series to handle pressure at depth. Atlas Copco Secoroc also provides jet subs that direct additional air up the column to assist in evacuation without increasing pressure at the hammer.

## Drilling with fluid

In rotary fluid drilling technique, a drilling fluid mix clears the hole of chips and conveys them to the surface for removal. Drilling fluid is a versatile medium that provides lubrication, cools the bit, and maintains the bore walls by caking them with slurry. Drillers mix natural and synthetic additives with the fluid to change its viscosity and density, as well as to treat the formation, protect tooling, and improve its ability to clean the hole of stubborn debris.

A common natural additive is bentonite clay. A bentonite mix flows freely while it is being pumped. When fluid circulation stops, it "gels." In its gel-like state the mix suspends the chips, preventing them from settling in the hole. When circulation begins again, the gel becomes as liquid as before. Bentonite mixes look like mud; hence, rotary fluid technique is colloquially referred to as "drilling on mud" in some regions.

## Overbalanced drilling

Formation permeability allows gas and fluids to flow toward the well bores. This is ideal for production, making it easy to use the well bore to drain the resource. While drilling the hole, however, formation influx often present a problem and must be held back.

The weight of the column of fluid can be used to counteract the formation's pressure, holding back the influx of any gases and fluids present within it. This is why rotary fluid technique is known as overbalanced drilling. Currently, drilling with rotary fluid technique is the only feasible method of controlling a high pressure formation.



*A tricone bit has three roller cones on one bit body, each placed so that its buttons complement those of the cones on either side of it. It can be used for rotary air and rotary fluid drilling methods.*



*The sharp edges on the carbide blades of a drag bit shear formation material from the bottom of the hole.*



*Polycrystalline diamond compact (PDC) bits also cut by shearing action. Atlas Copco Secoroc PDC bits are the product of complex engineering, quality-controlled proprietary materials, and precision manufacturing processes to match formation requirements of deephole applications.*

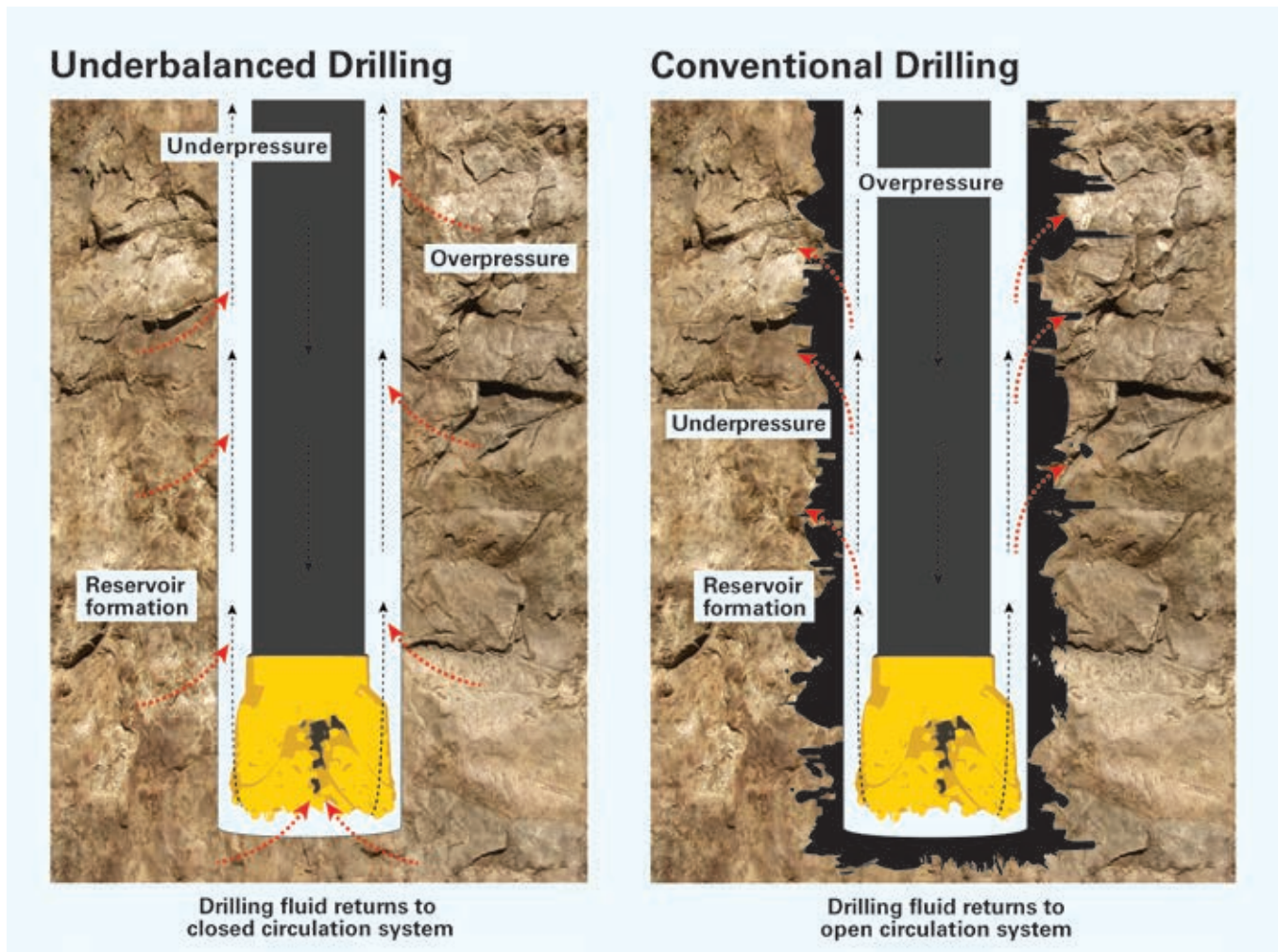

In underbalanced drilling, the column of pressurized air and cuttings in the bore is much less than formation pressure. Pressure relief at the hole encourages formation fluids and gases to flow into it. In applications that require formation control, under-balanced drilling is generally not an option. In overbalanced drilling, the weight of the column of fluid exerts more pressure than the formation pressure. This holds back influx and helps maintain hole diameter. Fluid weight can be increased by mixing additives that increase its density. Because it has more pressure, drilling fluid will also tend to force its way into fractures, and seams in the formation, sealing off influx.

While overbalanced drilling is beneficial while drilling the well bore, a consequence of the fluid column's greater pressure is that it tends to force itself and the solids it bears into the formation, lowering formation permeability or completely sealing it off. This side effect of overbalanced drilling is an especially great obstacle for energy companies drilling in tight sandstone formations and in shale oil and gas reservoirs. These unconventional resources are characterized by definition as having inherently low permeability. After a bore is completed in these reservoirs, the well requires stimulation techniques such as hydraulic fracturing to gain access to the formation's fracture system, creating more fractures as it can to enhance influx.

## Maintaining the hole

In unconventional oil and gas plays, the tendency of some shales to absorb drilling fluid causes them to swell, making it difficult to maintain the well bore's shape. Sloughing shales break away from the wall and fall onto the bottom hole assembly. This can pack off the drill. Just as weighted drilling fluids are used to hold back formation influx, they can also be used to push back on the well bore's walls, keeping them from swelling. Drilling fluid can also be formulated to prevent swelling and sloughing with a shale stabilizing additive.

In DTH drilling, fluids are also injected down into the bore to keep the hole open. Though not nearly the same

volume of drilling fluid is used, shale stabilizers can be added to prevent packing off the drill string from swelling and sloughing of the bore walls.

## Underbalanced drilling

In formations that do not require overbalanced drilling to hold back influx, some drillers have begun successfully using rotary air and DTH underbalanced drilling techniques. The first benefit in doing so is that drilling fluid is not forced into the formation. Using DTH can produce an added benefit. Vibrations from the operation of the percussive hammer have can help stimulate the formation, enhancing production capability



and reducing the need for as much hydraulic fracturing. This technique has shown greatest potential for use in unconventional resource recovery in hydrocarbon-bearing formations such as dolomitic limestone. Rotary drillers also use aerated drilling fluids to float chips up the column and treat corrosion, acidity, without overbalancing the formation. Underbalanced rotary techniques mitigate formation clogging, maintaining permeability in the vicinity of the wellbore and requiring less intensive hydraulic fracturing for production on completion.

## Mixing techniques: Role of top hole contractors

A top hole contractor specializes in the use of easily-mobilized, carrier-mounted drills to begin the vertical portion of a well. This means an energy company's conventional rig can drill more wells in a calendar year, since its time is dedicated to finishing wells to completion.

Top hole contractors typically drill only to the kickoff, the point where the well profile will turn horizontal to form the production laterals in a hydrocarbon source layer.

Since specifications for the top hole contracts most often stop well above the hydrocarbon-production zone, DTH is often a highly productive option for this type of work.

## Adjusting on the fly to changing conditions: Case study

How does a driller know in advance which drilling method will be most effective?

The best productivity comes from the ability to switch drilling methods on the spot. Kevin Mallin, a drilling consultant with Geolorn LTD of Callender, Scotland, helps plan and execute deephole drilling strategies at global locations for on- and offshore operations. He discussed one well for which the plan changed unexpectedly from hammers to PDC bits.

In this example, the job was drilling holes to provide grout-filling access to underground mine workings. The

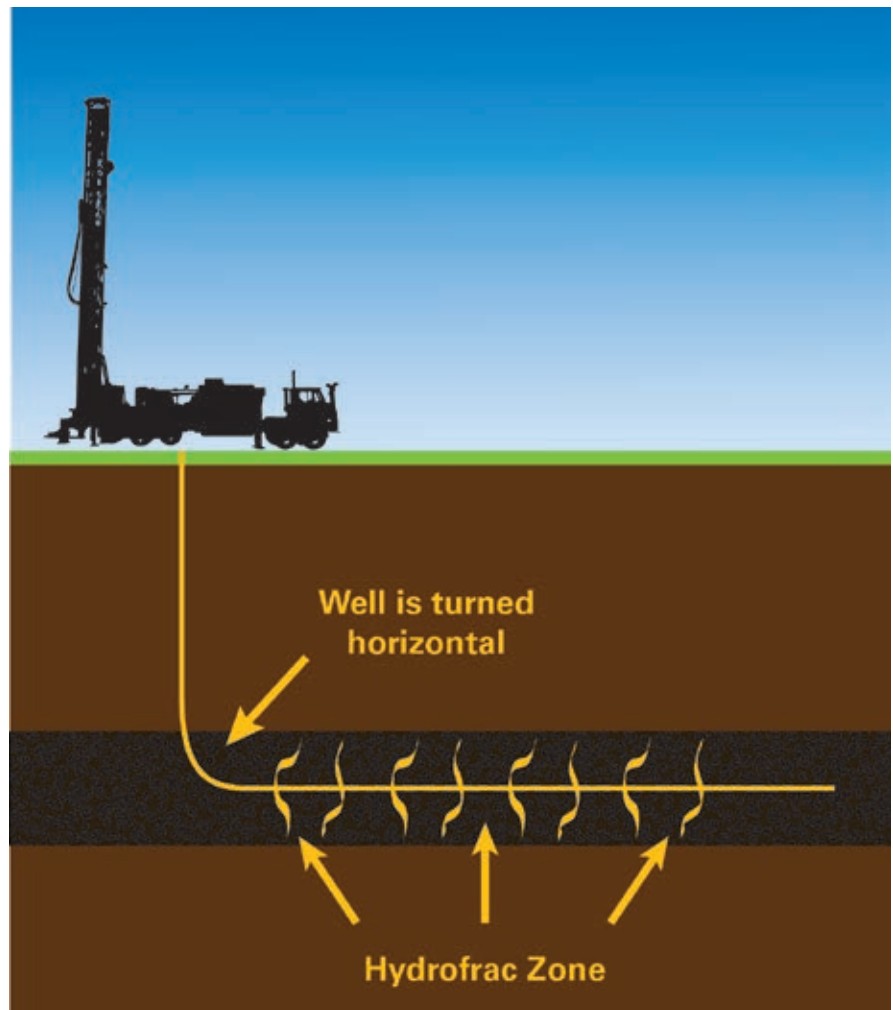

*"Directional motors" are BHA components with a slight bend in them. The angle of bend determines the maximum radius of the curve that can be drilled. While the motor is turning, it moves in a straight line. When it is stopped, it turns the hole in the direction of its bend.*

grouting stabilized the ground prior to construction that would take place over the site. Normally, the holes would be drilled with either top hammers or DTH tools through the sandstone layers into the voids.

However, once they started drilling, operators discovered an "altered" basalt flow that trended into a dyke, a T-formation in the ground profile. The basalt was brittle with ductile properties. Large pieces would break away, causing the DTH hammers to stall.

Mallin decided to change to PDC bits using an air/foam flush and add a stiff bottom hole assembly. The PDC bits in this case cut cleaner and much more quickly, since they were also drilling through roof timbers of the workings. Mallin believed that the basalt re-responded to shearing more

readily than hammering, despite the rock's compressive strength in excess of 250 MPa. Mallin said he often gets great results using PDC bits in softer sedimentary and clastic rocks, but that the driller needs to have a greater understanding of what occurs down the hole to use PDC bits effectively.

In most stable formations, except when the material is exceedingly soft, hammers are the ideal choice over tricones. When a hammer cannot be used, PDC and rotary fluid technique are a good Plan B.

## Jaco van der Merwe

VP of Marketing  
Deephole Drills

Joe Bradfield



Atlas Copco

RD20

atlascopco.com



# Tool selection

## New innovations give drillers greater productivity to meet contemporary market demands

With the myriad of drilling tools available today, selecting the correct tool for a specific task can be daunting. Atlas Copco has worked to simplify the process via descriptive nomenclature and versatility in its consumable offerings.

As an industry leader in drilling products, Atlas Copco offers a full line of tools for deephole drilling, including rotary air and fluid applications and down-the-hole (DTH) products. Atlas Copco designs reflect the expertise of over a century of pneumatic percussion tool research, design and manufacturing.

### Rotary tools—PDC bits

Wherever deephole formations present fluid and gas influx or hole maintenance challenges due to swelling or sloughing, rotary technique with drilling fluids may be the only option. Rotary drilling is also preferable when holes are excessively wet or soft.

Throughout the industry, drillers have found the wide variety and aggressive productivity of Atlas Copco's PDC line to be a cost-effective alternative to traditional roller cones for both air and fluid rotary technique.

PDC is the commonly used industry term for a drill bit using polycrystalline diamond compact inserts placed on the cutting face of a PDC bit's blades. Unlike roller cone teeth and DTH buttons that induce tensile forces to cause formation material to fail, PDC inserts continually shear material away from the bottom and sides of a hole as they are rotated by the drill string or by a



PDC bits, such as the Atlas Copco "Dirt Digger" line, feature polycrystalline diamond compact inserts on the cutting faces. The flat parabolic design of these bits offers maximum protection while drilling in non-homogenous and unconsolidated formations.

directional motor. PDC bits offer several advantages over roller cones, including smoother drilling operations, longer bit life and increased penetration rates.

Modern PDC bit configurations have greatly surpassed the first designs offered by the industry. The basic shape of Atlas Copco PDC bits fall into two categories: flat parabolic design for maximum protection while drilling in non-homogenous and unconsolidated formations and tapered parabolic for maximum rate of penetration in homogenous and consolidated formations.

Bits ranging in diameter from 7-7/8 in (200 mm) to 36 in (914 mm) are offered in either a 4140 alloy steel body or in sizes ranging from 5-7/8 to 17-1/2 inches (149 to 445 mm) in a cast-infiltrated tungsten carbide matrix shell for maximum erosion and abrasion resistance.

The use of 3D design programming and precision CNC machining has created a variety of bits suitable for any set of rotary conditions. Atlas Copco Dirt Digger PDC Bits are cost-effective, steel-body bits particularly well suited for shallow oil and gas drilling. The 3- to 5-5/8-inch Dirt Digger D013 features a flat parabolic design for maximum

protection while drilling non-homogenous and unconsolidated formations.

The Atlas Copco PlugMaster PDC bit, as its name implies, is specifically designed for drilling through production bore plugs used in the fracture stimulation process.

### DTH tools

Cuttings can be removed from a hole by circulating pressurized air through the hole. When the air is also used to power a pneumatic hammer "down the hole," it is referred to as DTH technique.

A DTH hammer is a pneumatically-operated piston placed immediately behind the bit. The hammer transfers impact energy through the bit into the material to be removed. To be most effective, several drilling parameters must be balanced. Impact force must be controlled so that it is sufficient to defeat the material's tensile strength. This will cause the material to fail in numerous tiny cracks without excessive force that would crush it into powder, slowing ROP and shortening tool life. Ideal performance produces uniform chips for efficient evacuation up the column of the hole's annulus in a

stream of air. Initially, exhaust from the hammer may be adequate to clean the hole of chips. As the hole progresses, additional air volume is required to move the ever-increasing mass of chips up the column of the annulus, or void between the bore hole wall and the drill pipe. Pressure must be great enough to overcome terminal velocity of the chips without eroding the pressure differential between the hammer and its environment.

Though rotary drilling seems simpler in principle, several advantages of DTH drilling make it the most productive and cost-effective method in any formation that permits its use. One is that unlike drilling fluid, air does not have to be sourced, transported to the drilling site, recovered, shaken or settled to remove cuttings and then treated and disposed of.

Another benefit is the greatly reduced expense of drilling fluid and additives. Though some drilling mixes and foams are used in some applications, the quantity is a fraction of that required for rotary drilling.

The most well-known advantage is DTH's superior ROP: two to five times greater than rotary technique. The harder the formation, the greater the advantage of using DTH in place of rotary method. Atlas Copco Secoroc deep-hole models of its Quantum Leap (QL) and Total Depth (TD) hammers feature hybrid porting. Airflow is managed both through fixed porting and the QL-style adjustable air check valve that prevents the drills from running "off bottom." High pressure air in excess of the hammer's optimum cycling requirements bypasses the hammer.

## Underbalanced drilling

Ideal applications for DTH drilling tend to be long wellbore sections with minimal formation pressures and minimum water influx, and in medium to hard rock that would slow conventional rotary tooling. Formations with high dip angles drill with less deviation using DTH due to its lower weight-on-bit requirements. Formations with lost circulation problems are more economical to drill with DTH. Two primary obstacles for DTH to overcome



*Atlas Copco's down-the-hole (DTH) hammers are the result of more than a century of pneumatic percussion tool research, design and manufacturing.*

as an underbalanced drilling technique are influx control and hole maintenance. Rotary drilling uses the weight of the fluid combined with natural additives such as bentonite clay and barite to cake hole sides and increase column density. The greater density "overbalances" the formation pressure with greater pressure in the wellbore, preventing kicks of influx or worse, blowout.

Overbalanced drilling, however, has a drawback in deephole oil and gas work, especially in low-porosity, low-permeability ("tight") reservoir rock. Overbalanced conditions in the well cause drilling fluid to invade the formation, sealing off migration pathways and obstructing the flow of hydrocarbons for later production.

Intentionally permitting drilling fluid to be less dense than the surrounding formation prevents drilling fluid invasion. Certain additives, gas injection technique, or a combination of both can cause the drilling fluid to be "lighter" than the formation. Influx is channeled with the drilling fluid to a rotating head and directed away from the drill through a discharge valve to a fluid collection pit and methane

igniter. Modern technique is blurring the traditional applications between the two methods. Just as drilling fluid can be lightened, imitating some of the benefits of underbalanced drilling, DTH is able to imitate the advantages of overbalanced drilling.

One DTH technique is misting. Just as air pressure and volume can remove a tall column of rock chips, it can also evacuate fluids. Adding liquid mixes to the airstream at the surface of a wellbore being drilled with DTH tools can help prevent shale sloughing and clay swelling, plus reduce risk of fire in the hole. Solutions that can be used include brine and surfactants, as well as sloughing, corrosion and fire inhibitors. Flow rate of misted liquids depends on air volume available for evacuation. Combined influx and misted liquids would typically not exceed 150 bbl/hour.

### Alf Stenvist

VP of Marketing  
Rock Drilling Tools

Joe Bradfield



# Ergonomics and safety



The Predator Drilling System has a tilt-out top drive that rotates out to receive pipe from its pipe skate. It achieves truly hands-free pipe handling.

## Focusing on the drilling industry's most valuable resource: its people

Atlas Copco was an early pioneer in ergonomics, realizing that any company's greatest resource is its personnel. Preventing fatigue associated with arduous and repetitive tasks helps keep workers safely performing at their best.

Modern drilling operations are more efficient than ever before. Many of the innovations that make this level of production possible evolved from the same studies that yielded improved ergonomics and safety. The results have proven time and again that safety and efficiency can be thought of as synonymous.

The goal at Atlas Copco's Drilling Solutions division is to provide deep-hole drillers with equipment that delays the onset of mental and physical

fatigue while enhancing safety. All Atlas Copco mobile water well rigs feature ergonomic improvements—from the TH60 and T3W deep well rigs up through the Predator Drilling System, specifically designed for the oil and gas industry.

## Deephole water well drilling models

The TH60 and T3W, deephole versions of the popular water well rigs, reduce physical strain through efficient mechanical design. They offer two different packages to choose from considering tripping speed, power transfer efficiency, maneuverability and off-road fuel management. Both models are equipped with almost identical ergonomics and safety features.

Each model's control console is placed so the operator has arms-length access to the table area. Full-width platforms allow the driller and helper to move freely about the work area. Dual drawworks and auxiliary hoist control options allow the driller or helper

to operate the hoists. This flexibility assures speed, along with safety and comfort.

Alternatively, pipe may be fed from the carousel, which employs a simple feature to reduce neck strain. The carousel's boots are marked to show when the top wrench is lined up with the flats. The driller is not required to look up during each joint.

The air-operated holding wrench at the table and foot-pedal-activated top wrench are "hands-free."

When the rotary head is retracted into the derrick, the hoist line is on the centerline of the hole. This means heavy tooling is safely positioned directly over the hole without physically shoving or pulling it.

Both rigs have a reputation for quick, safe handling of pipe and casing.

The deephole version of the T4W has 70,000 pounds of pullback, the same as the deephole versions of the TH60 and T3W. Similar to the TH60 and T3W, pipe can be loaded by an Atlas Copco T4W using either the carousel, which can hold seven drill pipes or one drill



Weighing 35,000 pounds (15.8 metric tons), the APL system is transported as an oilfield skid. It can handle Range 2 drill pipe and Range 3 casing up to 45 feet (14 m) and a tubular weight range up to 6,000 pounds, or 8 ¾ inch collars at 198 pounds (89 kg) per foot.

collar and five joints of pipe, or a dedicated hydraulic hoist and jib boom lift. The T4W takes 25-foot (7.6 m) lengths of 4 ½ inch (114 mm) key lock drill pipe with a 2 ⅞ IF connection. Efficiency of operation with enhanced safety was designed directly into the T4W pipe-handling system, as a T4W pipe tool secures both ends of the pipe and features a safety lock.

Atlas Copco also provides an optional casing handling system that uses the rig's feed and rotation systems. Threaded and coupled casing can be lifted with the rotary head and feed system using an elevator connected to the spindle. The casing can be pushed, pulled and rotated. The rotary head and torque limit control spin the casing together to the correct torque specifications. The casing is securely under control throughout the process.

Though drilling deep water wells is not always easy on the drilling team, the deephole versions of the Atlas Copco TH60, T3W and T4W make it as comfortable and safe as can be.

## RD20 XC

The RD20 XC has been designed specifically for use in the oilfield. Standard series RD20 rigs can also be outfitted with a range of conversion kit configurations, upgrading Range II and Range III rigs with the XC model's oilfield features.

A new console layout designed with driller input simplifies rig operation. Pipe, collars and casing are handled by a virtually hands-free, tip-out hydraulic link and elevator system on the top drive. This allows the RD20 XC (and converted RD20 Range II and III rigs) to use API external upset (EU) oilfield pipe, also known as bottleneck pipe, in place of flush-joint RD20 pipe.

The 17 ½-inch (445 mm) API master bushing with available hydraulic slip assembly reduces manual labor and enhances safety while drilling in or tripping EU pipe. The same system is adaptable to oilfield casing using the top drive torque limit control to assure joints are made up to the specified

torque. An optional oilfield skid automated pipe loading system, the RD20 APL, provides true hands-free pipe handling. No hands touch pipe at any point during the process of positioning pipe for connections or tripping.

## Predator Drilling System

The Atlas Copco Predator Drilling System did not evolve from any one prior design. Every part of the design was purpose-built to meet current and anticipated oil and gas industry requirements: lowered non-drilling costs, improved performance and energy efficiency, and enhanced safety.

The three-part system is based on a carrier-mounted hydraulic top drive drilling rig with 220,000 lbf (980 kN). The second and third components consist of a matched substructure with integral ramps, and a virtually hands-free breakout and pipe-handling system.

A hydraulic floor crane on the substructure assists in rig-up and drilling operations, reducing heavy lifting and manual contact with the tubulars.

The substructure itself reduces manual labor during assembly and take-down since the table, master bushing, hydraulic slips and iron roughneck are part of the substructure and travel with it.

The Predator's skate, transported as a single skid-mounted load, is a complete pipe handling system that eliminates the need to have personnel in the mast during drilling operations. The skate is designed to handle drill pipe, collars and casing, including Range II (30 feet/9 m) or Range III (40 feet/12 m) oil field drill pipe and Range II or Range III lengths of casings up to 24 inches (610 mm) in diameter.

All together, the components of the Predator Drilling System make it an exceptional example of Atlas Copco's dedication to providing deephole drilling equipment that keeps crews working productively, efficiently and safely.

### Alex Grant

Product Line Manager  
Well Drilling

Joe Bradfield



# Pipe loader increases safety



This Atlas Copco file photo shows the ease of pipe handling with the RD20 XC.

## Oil and gas drillers benefit from hands-free features of Atlas Copco Automatic Pipe Loader

One drilling company in the Surat Basin, Australia, is relying on the safety and reliability of the RD20. Safety is a top priority for both the drilling and energy companies and is a driving force for implementation of new processes and tooling. The challenge is to reduce situations that compromise safety. Atlas Copco has designed an automatic pipe loading system (APL) for the RD20 for that purpose.

### A total community program

Drilling companies are looking for additional safety from innovations that reduce situations that can put their crews in harm's way. The Atlas Copco

RD20 automatic pipe loading and handling system not only exceeds expectations for increased safety but does so while increasing productivity of drilling operations.

The RD20 APL never requires hands to touch the pipe. From the time pipe is loaded onto a rack system after arriving at the site, to the point the pipe is added or removed from the drill string, it is handled entirely by the APL.

The APL is operated by the assistant driller standing off to the side of the platform, just over the driller's shoulder. The assistant controls APL functions with a wireless remote control unit that can rest on a stand or be carried with a shoulder harness.

The APL will handle drill pipe, collars, and Range 3 casing of varying sizes up to 13 3/8 inches (34 cm). Hydraulic slips allow pipes to fall one at a time into the cradle of the pipe-loading arm. Clamps engage the pipe, and the loading arm rises into position under the rotary head.

Additional safety is built into the clamping system, which cannot disengage if the pipe is raised above 15 degrees. The operator and pipe handler

must be in communication, as the pipe can only be released when the driller releases it.

This company has installed a camera system at the top of the tower so the driller can see when the pipe is properly threaded into the top drive. This saves the driller's neck from straining to see the operation from the working floor. The camera also ensures proper connectivity before the driller releases the clamps from the loading arm.

During the process, driller and assistant driller stand about 6 feet (2 m) apart, allowing them to communicate every step of the way with each other to ensure a proper connection is made. The floorman also has visual and verbal communication with the others, so he knows when to pull the slips holding the oilfield-style pipe.

The men are a coordinated team moving quickly, and automation further increases safety by reducing their fatigue from otherwise labor-intensive tasks of changing pipe or adding casing.

Including connections, the crew averaged a rate of 121 feet (37 m) an hour while advancing the drill string.



Top right: The camera was added to the tower so the driller can more easily see when the pipe is threaded. Bottom right: From his position, the driller can see the Pason screen and camera at the top of the tower. The assistant driller operated the pipe handler from a remote control just off his shoulder.

The drill crew was averaging 262 to 328 feet (80 to 100 m) an hour instantaneously drilling and 114 to 147 feet (35 to 45 m) an hour including connections. For instance, the well just previous had been drilled in one full shift plus the first hour of the next shift. That well was 2,130 feet (650 m).

They also use the Pason data system, which can be viewed at the driller's station or inside company trailers from any office around the world.

## Finding the seams

The formation in this region of Australia consists of Springbok Sandstone just below the overburden, Upper and Lower Juanah down to 525 feet (160 m), and then Tangalooma Sandstone to about 850 feet (260 m). The coal lies below these strata in the Taroom and Durabille coal seams. In the area photographed, the hole reached total vertical depth at 1,568 feet (478 m). The deepest they will run in the area

is around the 2,295 foot (700 m) range. The coal is found in multiple seams 1 ½ to 6 ½ feet (0.5 to 2 m) thick with sandstone between. Once they drilled to total depth, they opened each seam with a 16-inch (406 mm) reamer. The reamer collapsed as it moved down, with teeth that expanded when they reached the seam.

The hole was drilled with an 8 ½-inch PDC bit. They used 4-inch drill pipe and 5 ½-inch collars. They used two stabilizers 50 feet (15 m) back from the bit and 10 collars at the bottom of the drill string.

Specifications required the drilling company to use three sizes of casing with the APL including the 14-inch conductor casing, 12 ¼-inch surface casing and 7-inch production casing—each cemented in place after being set.

The lower half of the production casing was perforated pipe. Upon completion a packer and cement sealed off the surface aquifers from the production zones.

To keep the hole clean and stable while drilling, fluid mud was pumped at 450 gpm (28 L/s). The gas was not under pressure, and water had to be removed to get the gas flowing, so heavy drilling fluid was not used.

## Can they keep up?

The enhanced safety in the RD20 has not come with any trade-off in rig productivity. In this case it took just eight to 10 hours to move the entire setup 3 miles (5 km). The crew was able to finish one well and spud in on the next in less than 24 hours, proof that the RD20 APL has increased safety without holding back productivity.

## Acknowledgement

*This article first appeared in Deep-hole Driller magazine issue 1 of 2012.*



# Predator Drilling System



An Atlas Copco Predator oil and gas drilling system in operation shown positioned on its substructure. Predator is the largest of the Atlas Copco line of carrier-mounted deephole drill rigs. Its 220,000 pounds (90,800 kg) of hookload allows drillers to bore vertical, directional and horizontal wells to depths of 8,000 feet (2,400 m) in today's global oil, CBM and natural gas basins.

## Tough drilling issues are no match for the Atlas Copco Predator Drilling System

The Predator Drilling System is a new generation drilling rig designed to meet the needs of the evolving recovery techniques in the oil and gas industry. This innovative three-component drilling system consists of a mobile carrier, a substructure and a pipe handling skate.

The three components of the Predator Drilling System are designed to work together for maximum drilling performance, operating cost-efficiency, safety, and minimal environmental disturbance. The Predator is the result of 30 years of design history and experience based on

over 300 rigs in a similar class in the global oil patch.

The Predator Drilling System was designed to be exceptionally mobile and quick to rig up. The Atlas Copco design team placed the greatest emphasis on reducing non-drilling time and cost, as well as improving performance and energy efficiency with enhanced safety.

The result was a rig with an actual working hookload capacity of 220,000 pounds (90,800 kg), giving the Predator the strength and capacity to drill vertical, directional and horizontal wells in today's global CBM oil and natural gas basins.

## Unique approach to design

The design process began with a non-traditional approach. Rather than focusing on more obvious product features, the Atlas Copco team chose to develop a new product with measurably greater value than current drilling systems.

They reasoned that drilling rigs in this class typically spend less than half their time actually drilling. More time is spent mobilizing, rigging up, handling pipe and standing by while other operations are completed. The Atlas Copco team wanted to change that.

The team matched the rig to a breakout and pipe handling system requiring almost no manual intervention. This eliminated the need for personnel in the mast during drilling operations.

Another enhancement was to include a hydraulic floor crane on the substructure that could assist in rig-up and drilling operations. The crane reduced heavy lifting and additional manual intervention.

## Mixed Fleet Approach

Able to finish shallow oil and gas wells on its own, the three-part Predator Drilling System's mobility, rapid setup time, and powerful drilling capacity also make it ideal for a mixed fleet approach.

The mixed fleet approach allows land-based drilling contractors to capitalize on the strengths of two types of drilling rigs. Each rig completes its part of the drilling plan in the least amount of time and at the lowest possible cost. This approach results in a considerable savings in mobilization costs and time.

As a lightweight hydraulic top-drive rig, the Predator is used to start the wells due to its greater mobility and economy of operation. The system's rapid setup and rig-down allow it to be moved quickly from well to well drilling surface holes and pre-setting casing. Deephole conventional rigs follow behind to drill the deeper segments of the well.

The mixed fleet approach frees conventional rigs to spend more time completing wells that the Predator Drilling System started. The result is increased revenue generated from more wells in production at the end of a year without the expense of more conventional rigs.



The connection is flawlessly repeated joint after joint as the Predator system's pipe skate lifts pipe to the tilt-out top head of the drilling rig.

## Component Overview

### Hydraulic carrier drive

The Predator's unique single-engine hydraulic carrier-drive system is an innovative use of the rig's existing power systems. The carrier has a full-width, low-profile cab with all of the amenities found in conventional trucks. The single 950 hp (708 kW) engine powers both the carrier and the drilling rig, utilizing shared components rather than a second engine and drive train. This design greatly reduces overall weight and minimizes time and cost of maintenance.

In drive mode, the Predator's engine consumes less than half of its rated power, yet it is capable of full torque at any time regardless of speed. The hydraulic drive, coupled with a clutch and manual transmission, provide an exceptionally wide range of power and speeds. It was designed from the start to drive like a conventional truck or drill rig carrier. The carrier is equally effective traversing flat land as mountainous terrain.

The hydraulic carrier drive employs a dynamic braking system, which is both quieter and more efficient than conventional braking systems. The carrier also has "creep mode," a feature that gives a driver precise control

over vehicle placement in off-road or extreme driving conditions and while moving onto the substructure.

### Substructure

The Predator substructure, an integral part of the drilling system, serves as a strong structural base for the rig. It was designed to rig up rapidly, with reduced manual labor and assembly.

The table, master bushing, hydraulic slips and iron roughneck are part of the substructure and travel with it. Four hydraulic blocking jacks make leveling simple and fast.

A hydraulic crane with telescoping boom assists in rig-up and utility lifting during drilling operations. Operated by remote control, the crane boom can be centered over the hole or reach off the work floor to pick up loads from the ground. The main air/mud manifold is also located on the substructure for quick ground level hook up.

The large 190-square-foot (17.6 m<sup>2</sup>) work floor was designed to provide ample working space and configured with drill-crew efficiency and safety in mind. The two access stairways are hinged at the top, permitting adjustment to substructure height while keeping the bottom end firmly on the ground. Because the substructure is contained in a single load it can be deployed with

less assembly and manual labor than most other substructures, reducing non-drilling time and cost.

### Pipe skate

The Predator pipe skate is a complete pipe handling system designed to work as an integral part of the complete Predator system. It is a single skid-mounted load, which is positioned directly behind the substructure and attached to it. The skate was designed to handle drill pipe, collars and casing. It can handle 30-foot (9 m) Range II or 40-foot (12 m) Range III oilfield drill pipe as well as Range II or Range III lengths of casing up to 24 inches (610 mm) in diameter. Use of Range III drill pipe can save both time and money over Range II in frequency of pipe changes.

The skate has foldout pipe racks on both sides. These racks have hydraulic jacks for feeding pipe onto the skate for drilling and off the skate while tripping out. The skate can be supplied without racks if hydraulic pipe tubs or A-frame racks are to be used for loading and unloading the skate. Hydraulic jacks make setup and alignment quick and simple.

The pipe handling control system can be located on the work floor and/or at ground level. Usually a crewmember handles the loading operation on the skate and elevates the pipe to a fixed position behind the work floor. The driller grips the pipe and extends it to meet the spindle for makeup. After the joint is made up, he opens the clamp and retracts it. Then the crewmember lowers the trough and loads the next pipe from the racks.

The Predator skate improves on manual pipe handling. Its automated performance ensures constant, fast pipe-handling hour after hour. Atlas Copco Drilling Solutions thoroughly engineered and tested every component of the Predator Drilling System to be certain it operates as designed.

### Alex Grant

Product Line Manager  
Well Drilling

Joe Bradfield





# Going after the hard stuff



Colorado company uses Atlas Copco's RD20 to efficiently develop unconventional Coal Bed Methane reserves.

## Colorado company's Atlas Copco RD20 efficiently develops unconventional CBM reserves

**Pioneer Natural Resources relies upon the versatility of its Atlas Copco RD20 range III drill rig to reach depths and use a variety of techniques previously not offered by truck-mounted rigs. The RD20 navigates steep inclines and acute switchbacks to take the rig where Pioneer otherwise might not be able to go, from the Raton Basin to the Rocky Mountains.**

The Raton Basin stretches across the western United States from southern Colorado to northern New Mexico, running about 30 miles (48 km) long

and 30 miles wide. In recent years the energy has been coming more from methane gas in the coal beds than the coal itself. Extracting coal bed methane from this formation requires Pioneer Natural Resources to take its Atlas Copco RD20 up into the mountains to use a drilling method that was customized for this specific formation. Pioneer Natural Resources is a large independent energy company with a vertically integrated operation whose primary business is gas production. In-house services include a drilling rig, location construction equipment, pipeline installation equipment, cementing services, fracking services, workover rigs and a maintenance department—most of the major services required to put a hole in the ground and complete a well.

“Because we are out here where there are not a lot of support companies for the drilling industry, we need everything to keep the drilling operation moving,” said Pioneer drilling superintendent Bill Chase.

“Most other rigs are just too big to work in the upper elevations,” Chase said. “Gas well depths can range from 600 to 4,000 feet, depending on the elevation. The RD20 works well because the roads to reach drill sites have steep inclines and switchbacks.”

Chase added that the RD20 also handled the terrain well. “The topography out here is really rough. We routinely deal with inclines in excess of 10 percent. The RD20 is exactly what we need for its depth and mobility.”

As for versatility, the rig was outfitted and plumbed to drill using multiple methods. The rig setup included equipment for air hammer drilling, rotary mud drilling, and aerated water drilling using a down-hole motor with a PDC bit. Air hammer operations were supported by an Atlas Copco Hurricane B7-41/1000 booster. Combined with 1,250 cfm (590 L/s) rig air and 1,150 cfm (543 L/s) from an auxiliary compressor, the booster supplied 2,400 cfm at 1,000 psi (1,133 L/s at 69 bar).



The RD20's workspace design offers a driller a good vision of mud system and rig operation from the driller station.

Rate of penetration while hammer-drilling 7 7/8-inch (20 cm) diameter holes was about 200 feet (61 m) an hour, the equivalent of 6 1/2 to 7 rods an hour. Within a 48-hour period, having finished one 2,400-foot (731 m) hole, the crew could move the rig and set conductor casing on the next hole.

Using aerated water technique, Chase said, the crew could drill to 3,200 feet (975 m) at 160 feet (49 m) per hour, with a cycle time of four days, hole to hole. Depending on which method of drilling was in use, it took up to 14 loads to rig up on site. The rig, doghouse, pipe trailer and trailer-mounted auxiliary equipment were placed close together, so hinged or retracted catwalks gave the entire work area an elevated platform. This safety measure reduced the amount of climbing between ground and work area. Pioneer used Atlas Copco's QL

120 DTH hammer for its surface work, drilling the surface hole to depths between 250 and 1,000 feet (76 to 305 m), depending on well design. The well was then cased and cemented with 8 5/8-inch casing. Wells were drilled to total depth with a 7 7/8-inch bit and cased with 5 1/2-inch casing. For DTH hammer drilling, Pioneer used an Atlas Copco Secoroc TD60 DTH hammer.

Formations here included coal seams, sandstone and old lava flows—many geological variables that could cause loss of circulation. As a result, even though DTH hammer drilling was popular with the crews, aerated water drilling was also used on the deeper wells.

As the development moved to the higher altitudes, aerated water drilling was used more often. Aerated drilling is essentially underbalanced drilling with a mixture of water, foam and air

instead of mud. There is no set amount of air volume or pressure. Pioneer operated at 300 to 700 cfm (142 to 330 L/s) and 500 to 600 psi (35 to 40 bar). A choke valve was used to adjust the mixture, injecting just enough mixture, Chase said, to allow the hole to circulate.

Chase noted that drilling methods have continuously adapted to meet the challenges of reaching the CBM resources. "We couldn't do this 10 years ago. I think we've taken the RD20 to a new level. Natural gas is today's green energy, and now we can go after it in ways that were not available in years past."

## Acknowledgements

*This article first appeared in Deephole Driller magazine issue 3 of 2010.*





# XC is for 'Extra Capabilities'

## The world's first RD20 XC for oil field pipe is a perfect fit for the US Permian Basin

The Atlas Copco RD20 XC drilling rig is designed to use externally upset pipe, also called EU or "bottleneck" pipe. Though any RD20 can be converted to use EU pipe, the RD20 XC is designed from the factory as an oilfield rig. The modifications were the result of manufacturer-contractor partnerships, such as that between Atlas Copco and Jackson Drilling Services, LP of Justin, Texas.



The tophead of the RD20 XC, which has bails and a hydraulically activated elevator rated to 120,000 pounds (54 metric tonnes), is specifically designed for bottleneck pipe handling.

Since 1972 the RD20 drilling rig and its Atlas Copco generational improvements have been helping small, independent contractors drill natural gas and coal-based methane wells to stay profitable in a highly competitive industry.

The self-contained, high-production mobile rigs have proven so valuable that a version dedicated to working in conditions such of those of the United States' Permian Basin was designed and built. As with most Atlas Copco upgrades, modifications came from field experience reported from the contractors themselves and from Atlas Copco technicians, field representatives and distributors.

Jackson Drilling of Justin, Texas, had been waiting for the bottleneck pipe version of the RD20. A long-term top hole contract with a major operator created the opportunity for Jackson to be the first customer of the new RD20 XC. The "XC" stands for Xtra Capabilities. It was the first of its kind in North America, and Jackson Drilling

helped tune its new features in the field.

Set up just northeast of Alvord, Texas, the project consisted of drilling 12 ¼-inch (310 mm) holes and then casing each with range 3 threaded 9 ⅞-inch steel casing to 940 feet (286 meters). The center hole was straight down. The well bores on either side of it were to be angled away at 3 degrees.

Using a rig such as the RD20 to do the surface casing ahead of a conventional drill has become a common practice in the Permian Basin. Surface casing is required to mitigate environmental concerns such as ground water contamination, sealing off the hole past the point of concern.

A conventional drill will then move over the cased holes later to continue drilling through the bottom plug to a kick off point before drilling horizontally along specified paths. Continuing a well bore thousands of feet into targeted production areas increases rate of yield, which makes once unprofitable resources economically feasible.

Hydraulic fracturing and packing sand into the fractures allows oil to seep into the bores faster for collection.

## Clean operations

Another benefit of the mobile rigs is the relatively clean operation. Mike Tharp, Jackson Drilling Services drilling supervisor, pointed out that the quality of air coming from the RD20 XC rig's large exhaust filtration system is often higher than that of the air in metropolitan areas. Driving the rig through these towns, in effect, filters the city air, leaving purer air post-exhaust than enters its intake pre-combustion.

On the site of this case study, large hoses between the rig and a two-tier settling pit handled the bentonite mud mix Jackson Drilling was using to drive the mud motor.

The pad's logistics were easy to maintain in an orderly fashion around the rig. The mud pump was to one side of the RD20 XC; the water truck to the other. Tall racks of casing lay along



the far fence line. And a flatbed pipe trailer was backed up to the RD20's deck, which was the center of activity.

## Xtra Capabilities

Several differences between a typical RD20 and this RD20 XC were readily apparent. First, there were two large hydraulic makeup and breakout wrenches on the helper's side, as bottleneck pipe does not have the wrench flats that are found on standard RD20 pipe. The wrenches' pedestal mounts included adjustable pin points in 2-inch (5 cm) increments to accommodate a wide variety of pipe and collar sizes.

The table of the RD20 XC was about 1 foot (305 mm) lower than a standard RD20, making room for a tapered pipe bowl and slips in the master bushing. With slips in place around the pipe, the weight of the pipe forced the pipe clamps tighter around it in the bowl, preventing the pipe from dropping back into the hole during makeup and breakout.

The RD20 XC tophead differed from the standard RD20 in that it had bails and a hydraulically activated pipe elevator attached to it, rated to 120,000 pounds (60 tonnes). It was specifically designed for EU pipe handling. Jackson Drilling Services used a short pipe adaptor in the elevator to facilitate quick hookups with the pipe from the company's modified flatbed, which bore a fabricated hydraulic pipe advancer.

Jackson also purchased the optional directional drilling brake system for its RD20 XC. The system's dual-caliper disc brake provided more than 8,000 ft-lb of rotational torque to freeze drill pipe in place while the RD20 XC continued to pump mud at up to 3,000 psi. The slight bend in the mud motor would then influence the direction of travel. Sensors within the directional drilling section pieces pulsed information back up through the mud, which acted as an electrical signal conductor. The signal was read on a small panel giving azimuth (compass direction) and inclination. There is no limit to direction, only to radius, which is controlled by the amount of bend in a particular mud motor.



The RD20 XC handles this job's range 3 threaded 9-inch (25 cm) steel casing with ease.

## Why bottleneck?

The preference for external upset pipe in areas such as the Permian Basin is the design's unrestricted flow of mud through its upset connections. To make room for the threading, 2 7/8-inch I.F. flush-jointed RD20 pipe is only about 2 inches (5 cm) wide inside a joint. However, the internal diameter in EU joints is the same as the pipe itself. It is readily available through any number of suppliers and is more familiar to conventional oil field hands, explaining why it is often referred to as "oil field pipe."

## Quick learning curve

On this job both Jackson Drilling's dayshift and nightshift crews were onsite working together. The company used dual training to ensure procedural consistency by learning the rig's operations together. Tharp said that the crew picked up on the RD20 XC very quickly. They had only used the rig on three pads together but were already

developing a high-production rhythm. Owner Doug Jackson agreed, saying, "This is only about their eighth hole with this rig and they have it down."

On this hole the crew was averaging a 30-foot (9 m) section of pipe in about 11 minutes, including connection time, an average of 2.7 feet (0.8 m) per minute. The longest time was 17 minutes, again including connection time. Drilling conditions were topsoil then sandy clay, red and gray shales, and occasionally soft to hard limestone.

Jackson Drilling Services drilled and cased the three 940-foot (286 m) holes in just a week's time before moving off the site. The holes were immediately cemented by a subcontractor. Completing the top holes this way maintained the client's leasing agreement and left the well heads ready for a conventional rig at a future date.

## Acknowledgements

*This article first appeared in Deephole Driller magazine issue 1 of 2011.*





# Nature's building blocks

## From hydraulic fracturing to carbonated beverages, drilling company finds markets for CO<sub>2</sub>

Reliant Exploration & Production, a division of Reliant Holdings, Ltd. out of Midland, Texas, is one of the companies developing the Bravo Dome formation near Bueyeros, New Mexico. The CO<sub>2</sub> reserves found there are some of the purest CO<sub>2</sub> to be found. It is present here in such quantities as to reward any who are able to access it. Reliant's new Atlas Copco RD20 is the perfect drill rig for the task, offering mobility and performance to reach the gas formation.



The site layout included both mud and air drilling options. Shown here are the mud boxes between the compressor trailer and pits.

When carbon dioxide (CO<sub>2</sub>) reserves were found in New Mexico's northeast corner in the 1940s, the market for the gas was uncertain. Today CO<sub>2</sub> is sought after because of its use in everything from refrigerated food shipments to manufacturing to enhanced oil recovery (EOR). The Atlas Copco RD20 is the perfect drill rig for use in this market, offering mobility and performance to reach the gas formation.

EOR technology using CO<sub>2</sub> drew Freddie Vanderburg, Reliant board chairman, into the petroleum business. CO<sub>2</sub> was initially found here in wells as shallow as 600 to 800 feet (182 to 244 m). Today the gas is found at depths between 1,900 and 2,950 feet (579 to 900 m) from surface in the Tubb Sandstone formation. The gas zone is about 80 feet thick. The gas is trapped in the formation by a salt seal 30 to 40 feet (9 to 12 m) thick. Experts attribute the gas to previous volcanic activity and believe the Bravo Dome may be a regenerating field, at least to some extent.

Reliant leases the center of the formation where the gas is found at around 2,300 feet (700 m) below surface. The area covers about 34 square miles (88 km<sup>2</sup>).

## Supporting the oil and gas industry

Reliant Holdings operates many businesses that revolve around the production of CO<sub>2</sub>. Its petroleum transfer business operates under the name FloCO<sub>2</sub>, and the food business operates under the name Reliant Gases. FloCO<sub>2</sub> supplies CO<sub>2</sub> to the oil and gas industry for EOR including well stimulation and hydraulic fracturing as well as pressure control treatment.

To get the gas to market, a pipeline runs from multiple locations in the west, including the Bravo Dome, to the Permian Basin CO<sub>2</sub> hub in Denver City north of Odessa. Today the oil fields of western Texas are using CO<sub>2</sub> to boost production because the price of crude is so high that maximizing recovery

pays off. CO<sub>2</sub> makes good sense for enhancement techniques like hydraulic fracturing, said Vanderburg. "For opening up a well, CO<sub>2</sub> offers many benefits. With CO<sub>2</sub>, 70 percent less water can be used versus a conventional fracturing," Vanderburg said.

No swabbing unit is needed, and the caustic nature of CO<sub>2</sub> assists in some formations by etching the formation. This eliminates the need for additional acids. It also reduces the risk of swelling clay formations, so it is cleaner. The fact that there is less waste water to dispose of also means a reduction in contamination risk with consequent savings in overall cost.

Recent research has found CO<sub>2</sub> to be important in the development of new fuels. For example, offshore oil is the result of decayed biomass, specifically algae. Discovering that algae eats CO<sub>2</sub>, scientists learned to make synthetic oil from algae, without the millions of years it took to make oil typically pumped up from underground and undersea oil reservoirs.



CO<sub>2</sub> is stored in large insulated tanks to keep it in a gaseous form.

## Food grade

The Bravo Dome gas is a good resource for the food industry because of its purity. “The gas here is nearly perfect at 99.99 percent pure,” said Vanderburg. CO<sub>2</sub> can be stripped from other processes including ethanol production and other gas formations, but pure CO<sub>2</sub> is extremely rare.

Dry ice is often used for transporting food. Reliant Gases, a Reliant Holdings company, supplies food industry giants such as Cargill and Tyson with dry ice. It also supports convenience stores with carbonated beverage fountains.

“We supply retail stores with 250-gallon tanks and drive route trucks to fill the tanks. There’s a good chance that if you got a Coke at a convenience store today, it was carbonated by us,” said Vanderburg.

CO<sub>2</sub> is transported in a liquid form by decreasing its temperature to between -53 and -20 degrees Fahrenheit (-47 and -29 C). It takes 17,000 standard cubic feet (scf) (481 m<sup>3</sup>) of CO<sub>2</sub> gas to make 1 ton (0.9 metric t) of liquid CO<sub>2</sub> and 2.8 tons (2.5 metric t) of liquid CO<sub>2</sub> to make 1 ton (0.9 metric t) of dry ice.

Vanderburg said, “Some wells can produce a million scf (28,317 m<sup>3</sup>) a day, but 500,000 scf (14,158 m<sup>3</sup>) is more common.” He added that wells

can have a long life. For instance, some have been producing since the 1970s.

## RD20 advantage

Vanderburg bought his RD20 as a low-hour used rig in good condition, but having a common rig with available parts was an important benefit when selecting it.

They purchased the rig with 7,700 hours. It needed some minor work on the table area and main valve. “I like the safety factor with this rig,” said Vanderburg, comparing the RD20 to conventional drills used in the region. “We don’t have people slinging chains or climbing up the derrick.”

The rig was also easy for the crew to learn. Driller Josh Wheeler III said getting up to speed was “no more than grabbing the handles and watching the gauges—8,000 pounds (3,630 kg) on a conventional rig’s string is the same as 8,000 pounds of pull-down on an RD20.”

## Drilling process

The rig was set up to run on mud and air. The company wanted it to be versatile for the formation, combining the speed of air and down-the-hole hammer drilling with the control that comes

from mud drilling, although CO<sub>2</sub> is not combustible.

To start off the well the crew began drilling with a 12-inch (30 ½ cm) hammer and a 17-inch (43 cm) button bit. They ran into heavy water at 15 feet (5 m) with a sandstone bottom at 40 feet (12 m) that was trapping the fresh water at 100 gallons (378 L) per minute.

Conductor pipe was set at 40 feet (12 m) on this project. The surface casing was set to 700 feet (213 m), and then the hole was drilled to depth. The production hole was drilled at 7 ⅞-inch (20 cm) diameter.

Casing the well was a bit different than for similarly profiled wells because of the caustic nature of CO<sub>2</sub>. They cemented 5 ½-inch fiberglass casing to 2,000 feet (610 m) with steel at the bottom 200 to 300 feet (61 to 91 m). “Steel alone would rust out in three years,” said Vanderburg.

Ultimately Reliant will drill an estimated 150 wells in a year, with one well per 160-acre (64 ha) quarter section of land. The rising demand for CO<sub>2</sub> ensures that Reliant’s RD20 will be busy for years to come.

## Acknowledgements

*This article first appeared in Deephole Driller magazine issue 2 of 2011.*





# Oil and gas drillers turn to 'mixed fleet' approach

## Use of RD20 to drill surface portion of production wells is both more productive and economical

Key Energy Services uses an Atlas Copco RD20 to drill 500-foot surface holes and set surface casing. Then the company moves one of its Helmerich & Payne FlexRigs over the hole to complete the well bore to total depth. This mixed fleet approach in the Permian Basin capitalizes on the RD20 rig's greater mobility, lower day rate, and enhanced safety.



The RD20 drill rig's quicker set up time and far fewer trailer-loads of drilling and ancillary equipment compared to conventional oil and gas rigs result in increased productivity and greater economy.

The advantage of drilling and casing the initial profile of a production well with an RD20 comes from its fewer components and equipment to rig-up. The smaller drill rig can get on and off the pad in a shorter period of time. Setting up the RD20, drilling, casing and cementing the upper bore takes on average only two to three days. Larger rigs are then spared the initial stages of creating the cellar and upper sections of the well bore and can be dedicated to the type of drilling they excel at: drilling at comparatively high instantaneous penetration rates to greater total depths. Key Energy Services uses its RD20 to drill 10 to 12 holes per month, in diameters specified at 12 ¼ or 14 ¼ inches (311 or 362 mm), to depths of about 500 feet (150 m).

It takes just four hours to rig the company's RD20 up compared to the four days it takes to set up the a super-single drill rigs. With only one mud pump and two diesel pumps to move fluid in and

out of the pit, the drill pad does not require nearly the equipment and site preparation necessary for larger rigs.

Drilling operations require only drill pipe, collars, and pipe racks along with a tooling box of smaller equipment such as bits, slips, cable bales, and tongs. Ancillary equipment consists of a diesel fuel tank and a water tank, and a tool trailer, dog house, and two light towers. These are easily loaded or towed to the next drill site so the RD20 can stay ahead of multiple conventional drill rigs. Moving the RD20 from one Key Energy Services pad to another requires two flatbed semitrailers, a sliding skid-deck truck and the crew's pickup trucks.

Jeff Woods, Key Energy Services' drill superintendent, said, "A two-day surface hole translates into less time over the hole than a larger rig, which really adds up."

Key Energy Services uses a saver-sub in the drill string with crossovers dropping production pipe sizes from 6 ½ inches (165 mm) to 5 ½ and 4 ½ inches (140 and 114 mm). Key Energy drillers believe a shock-sub is the key to the string. Tool pusher Tracy Wells said, "The shock-sub takes a beating, not the rotary head. It takes 50 percent of the string." They rebuild the shock-sub about every six holes.

Driller Adam Wells said some drillers will occasionally put 7,000 to 8,000 pounds (3,200 to 3,600 kg) of weight on the tricone bit. The Redbed formation requires only about 5,000 pounds (2,300 kg). The Redbed is a reddish-colored, clay-like shale stratum in the West Texas Permian Basin oil field roughly 200 to 1,400 feet (60 to 430 m) from surface. Wells is extra attentive on the controls in this formation. "There



are times the bit will go quiet and just drop. It's not uncommon." This is a result of softer or sandier formations that can require swabbing the hole to clean it. Each well can vary significantly from other holes drilled close to it. One, he said, took half the time of a typical well.

Key Energy Services' drilling crew pumps 320 gpm (20 L/s) of water while it drills with a tricone in this formation. "We are not concerned with pressure while drilling here. It doesn't take much to lift the cuttings," Wells said.

Fresh water is used for flushing, with occasional polymer sweeps every other joint and upon completion. The sweeps maintain the integrity of the hole and help to lift stubborn cuttings. Crews trip out the drill string at the conclusion of their 12-hour daylight shifts to ensure nothing falls back on the bit overnight.

The RD20 crew averages a well every two days. Allowing for time to cement a hole, the crew can move every few days. Wells said this crew works well together, resulting in a 10 to 12 well-per-month schedule.

Danny Tate, district manager for Key Energy Services, said use of the RD20 has had an impact on work schedules. Since the RD20 crew only operates during the day, it reduces a potential for fatigue-related problems. "As far as an oilfield job, this is about as close to a 9 to 5 job as you're going to get," he said.

The RD20 requires a crew just a third of that of a big rig. Once the surface hole is drilled and cemented, the RD20 can leave the pad while it cures off to another job. A big rig, however, might have to sit idle two to three days between grouting the hole and drilling again.

Tate pointed out the moving costs are also a lot less with the RD20. "It costs \$70,000 to \$80,000 to move a big rig versus \$5,000 to \$6,000 for the RD20."

Overall, Tate sees the trend toward using rigs like the RD20 to set surface casing on production wells as having nothing but benefits for the entire oil and gas production industry.

## Acknowledgements

*This article first appeared in Deephole Driller magazine issue 1 of 2012.*



*From the bit to the drill pipe multiple crossover connections drop the size from 6 1/2 to 4 1/2 inches. A shock-sub in this section absorbs half the bounce from the bit to the rotary head.*



*Packing up gear and tooling is quick with the cage and winch. The cage easily loads on a flatbed to move to the next site.*





# Tapping into a hot market

## Geothermal drilling in Australia shows RD20 deephole rig also an asset outside the oil and gas market

The Atlas Copco RD20 XC hydraulic top-drive drill rig that has been used successfully on Queensland's gas-rich Bowen and Surat basins in eastern Australia was deployed on a quite different application in the west. JSW Australia, a drilling company providing a wide spectrum of drilling services, has put the rig to work creating geothermal loop fields for a school's heating and cooling project.



JSW Australia's Atlas Copco RD20 XC is a high-powered compact, hydraulic top-drive rig that sees plenty of work in the geothermal industry.

Operating out of bases in Perth and Kalgoorlie, Western Australia, and a member of the Hughes Drilling Group, JSW Australia provides grade control drilling, drill and blast services, water well drilling, resource definition drilling, exploration drilling, paste and underground service holes, casing advance drilling, well control with bop and test pumping. As the rising demand for geothermal heating and cooling in Australia requires rigs with deeper drilling capability, JSW Australia finds itself well-suited for this niche as well, since JSW's new Atlas Copco RD20 XC high-powered rig with high power and compact mobility is ideal for drilling test holes and creating vertical loop fields in geothermal applications.

JSW was formed from the March 2010 management buy-out from Ausdrill-Brandrill of the original Strange Drilling business established as a single-rig operation in 1996. JSW's board and management team, including former Brandrill managing director Jeff Branson, have more than

500 years of collective drilling-related experience.

With fully-equipped workshops in Perth, Kalgoorlie, Boddington and Port Hedland, the company is able to maintain an expanding fleet of machinery to high standards.

### Hale School Project

Tim Westcott, JSW's veteran water well division boss, described the Hale School project in Perth's western suburb of Wembley Downs as an example. Hale is one of the state's oldest independent schools for boys. Its campus is located on a 118-acre (48 ha site about 8 miles (13 km) northwest of Perth and a mile from the coast. The project focused on using ground source heat pumps to warm the swimming pool. Other metropolitan schools, including St. Hilda's and Christ Church Grammar, had already adopted geothermal for swimming pool heating. Many schools, municipalities and private residences across Australia had already been using

geothermal technology to both heat and cool buildings.

The Hale School geothermal project's principal benefit would be year-round use of a pool heated at minimal energy costs and with minimal CO<sub>2</sub> emissions. At a time when state electricity tariffs were continuing to climb and environmental impact had become a major public concern, it was a welcome investment.

JSW started by drilling pilot holes in sedimentary formations 3,300 feet (1,000 m) below Hale School to measure temperatures and calculate the geothermal potential of the Yarragadee aquifer beneath the school grounds. Then JSW bored a deep geothermal bore to tap warm water for the system's heat exchangers. Once the heat was extracted from the earth's ground water for heating the pool, the cooled water was re-injected into a shallower part of the aquifer through an injection bore JSW had drilled. JSW drilled, constructed and tested both deep bores within a four-month timeframe. Once



Arguably the world's most successful shallow oil and gas rig in the 120,000-pound class, the RD20 has become a fixture on Queensland's coal basins.

the hole was logged, hydrogeologist consultants worked out the depth to set the screens, a crucial part of the project. Construction of the pool and of the heat exchanger was handled by a contractor specializing in that work.

### RD20 XC versatility

JSW's RD20 XC unit joined three Atlas Copco TH60 water well drilling rigs in its fleet. The TH60 is also a proven, versatile rig whose engine provides up to 550 hp (410 kW) even while reducing overall rig weight and improving weight balance, since the single-engine power source is used for both transportation and drilling operations. The rig can be set up to handle pullback ranges from 40,000 to 70,000 pounds (178 to 311 kN) and supports a wide range of JSW's drilling services.

The RD20, however, is arguably the world's most successful shallow oil and gas rig of 120,000-pound (53 tonne) class rigs. The RD20 has become a fixture on Queensland's coal basins, where coal seam gas drilling has rapidly grown in recent years. By 2013, more than 250 RD20 drilling rigs were

operating worldwide. Westcott said the highly mobile rig with its rapid set-up capability was flexible enough to adapt to almost any location. It has a patented carriage feed system and detached-table design for exceptional performance and economy. The table can handle up to a 30-inch drill casing. Overall it has the structural strength to handle tough drilling conditions.

"It's a very good machine," Westcott said. "You can run Range 3 gear on it. It's got plenty of power at 120,000 pounds (534 kN) of pullback, so you're good for 3,900- to 4,920-foot (1,200 to 1,500 m) holes. It'll do us for just about everything we want to do at this stage."

### Geothermal use increases

CSIRO, a government-funded Australian agency, has constructed a bore-field to supply cool water for the cooling of the new Pawsey Centre super-computer at the Australian Resources Research Centre in the Perth suburb of Kensington. The Pawsey Centre supercomputer was designed to be one of the world's most powerful computers and will be used for the Square Kilometre Array

telescope located in Western Australia. The geothermal cooling project will use heat exchanger technology, with cool water passing through and cooling the building. The warmed water will then be reinjected back into the aquifer. Savings of up to 10 million gallons (38 million L) of water each year are anticipated with the use of geothermal compared to a standard cooling tower solution.

A leading UWA geothermal scientist, Winthrop Professor Klaus Regenauer-Lieb, said recently that the Perth Basin under the Swan Coast Plain had the ideal geological settings to aim for the goal of "a zero emissions geothermal city."

"The new CSIRO Geothermal project will help to establish Perth as the first geothermally cooled city, and we will work to advance the geothermal industry to make this vision a reality," WA Mines and Petroleum Minister Norman Moore said.

### Acknowledgements

*This article first appeared in Deephole Driller magazine issue 1 of 2013.*





# Carizzo Sands—too loose to walk on but not to drill

## RD20 III XC fills the gap even on Carizzo-Wilcox formation's dune-like surface

The Carizzo-Wilcox aquifer's outcrop south of San Antonio, Texas, in the United States starts as a beach-like sand. It is a valuable and copious resource for oil producers as part of the larger Texas Coastal Uplands Aquifer System. Contracted to drill 1,000-foot (300 m) deep wells on the Carizzo Sands, one water well company used a bulldozer to tow equipment into position, including the company's Atlas Copco RD20.



This Atlas Copco file photo shows the ease of pipe handling with the RD20 XC.

## Oil and water go together

Water Well Services of Pleasanton, Texas, engages in agricultural, municipal and commercial water well drilling, specializing in oil pad support for major oil producers. James Forehand, vice president of Water Well Services, explained that all oil well developers and producers need water for drilling and for hydraulic fracturing. For this reason, almost every oil well in the region has an accompanying water well. A March 2013 University of Texas study announced that the region would see a steady rise from the 5,400 permitted oil wells in the region at that time of the study's publication to more than 24,000 wells over the next 10 years.

While there is very little surface water in the area, ground water is plentiful. From its outcrop, the underlying 800-foot-thick (250-m) Carizzo-Wilcox aquifer south of San Antonio downdips toward the coast at 100 feet per mile

(49 meters per kilometer) on average, though it ranges from a mere 24 feet (7.3 m) to more than 400 feet (120 m) at various points. Most of Water Well Services' customers want about 1,000 gallons per minute (3,800 lpm), but Richard Bartosh, Water Well Services' drilling superintendent, said wells here yield up to 3,000 gallons per minute (11,350 lpm), depending on how they are developed.

Water Well Services' Atlas Copco RD20 III XC, a self-contained, mobile drill rig, is the smallest rig in its fleet. Its next smallest drill is a double jackknife rig, which takes Water Well Services 18 flatbed trailer loads to mobilize. It may take a week on site to set up the jackknife rig to drill a hole. The company had originally purchased the RD20 XC to expand their services, increasing the market range of its drill fleet such as taking on large municipal jobs. Forehand said, "You can back the RD20 up in a 200-square-foot (60 m<sup>2</sup>) space and go to work."

Having used the rig for a year, he believed the RD20 XC to have a place in the oil field as well, performing as a self-contained mobile deephole drilling rig designed to endure in the South Texas geography, especially on the Carizzo Sands.

Bartosh said, "You can't walk in this sand bowl, let alone drive in it."

He described the first Carizzo well that Water Well Services completed with the RD20. The contract was to drill and case a 450-foot (137-m) water well near Poteet, Texas. The loose ground conditions there have made the area ideal for peanut and strawberry farmers, and Poteet is well known for its annual strawberry festival. The conditions are not conducive to drilling, however. The well required a 17 1/2-inch (444.5 mm) hole for 12 3/4-inch (324 mm) steel casing with a 12-inch (305 mm) IO steel screen. Bartosh said the weight of the string alone was enough to drive the hole. Average rate



Richard Bartosh, drilling superintendent for Water Well Services Inc., discusses with Mike Epley of Venture Drilling Supply (at right) how the RD20 III XC performed drilling a 450-foot, 17.5-inch diameter well on the Carizzo-Wilcox aquifer 30 miles south of San Antonio.

of penetration was kept to less than 45 feet (13.7 m) per hour with bentonite at 10 barrels a minute to adequately cake the sides. Chips were coming out at 10 feet (3 m) per minute.

In cases such as this it is not desirable to drill with air, which would quickly create voids in the formation. And Water Well Services will sometimes drill to 1,200 feet (3,600 m) or more: deeper wells bear the risk of encountering methane pockets. Therefore, mud drilling is the method of choice in these conditions.

Forehand and Bartosh also warned that drilling too fast with mud, especially as large as the bores that their customers require, comes with a risk of collapsing the hole.

It took three days to set up and drill the well. Once the five-man crew towed in pipe and casing trailers, a water truck and big pumps, they were ready to drill.

Though small in comparison to Water Well Service's jackknife rigs, the RD20 XC, whose initials stand for "extra capabilities," is a powerful drilling rig with a 755 horsepower (522 kW) engine and 120,000 lbf (534 kN) of pullback. It comes equipped with bails and a hydraulically activated elevator for oil field pipe.

The RD20 works with a smaller crew, and connections are fast, so there's lower labor and overall operating costs. Forehand believes times will continue to improve as the crew gets used to working on the rig.

As for safety, Forehand said the RD20 requires a smaller crew and doesn't require any climbing, no derrick man, so there's lower labor and overall operating costs.

The RD20 safety innovations give Water Well Services an advantage with their oil field customers. Forehand said,

"Today's oil field customers are all about safety. They don't want to see '70s-style rigs, with spin chains and all that manual labor. Retrofitting those with pipe spinners, trying to reduce manual labor, they are still more cumbersome, hazardous."

Water Well Services can also use the RD20 for some of its agricultural irrigation projects and to support development and production of its Eagle Ford Oil Field customers' oil wells. Such a versatile rig guarantees that Water Well Services can stay busy even without the favorable 10-year forecast for continued oil and gas well permitting.

## Acknowledgements

*This story first appeared in Deephole Driller magazine issue 1 of 2013.*





# Clean water for Panama

**Tough landscape and complex drilling conditions require a powerful rig, a mix of techniques and reliable tooling**

**Atlas Copco in Panama supports drilling equipment for clean water development. The rugged terrain isn't an obstacle to the T3W getting to difficult locations.**

The Panamanian government supports the water needs of its people with two development entities. One is the Institute of Water & Infrastructure (IDAAN). The other is the Ministry of Development (MDA). They both use Atlas Copco drilling equipment to accomplish their goal.

Supervising manager for rig maintenance in Panama, Nancy Gaitan, oversees both the IDAAN and MDA fleets, which include three T3Ws, four TH60s and three TH10s. While some of the rigs have been working hard for many years, such as the 26-year-old TH60, IDAAN adds new rigs as it can. The new rigs most recently acquired were three Atlas Copco T3W top drive drilling rigs.

Atlas Copco drilling equipment in Panama is supported through a Customer Center managed by Business Development Manager Hugo Arce. Arce, who also oversees all market growth throughout Central America and the Caribbean, said his focus was on training highly skilled technicians that would support the ongoing development of Panama: "The current expansion of the Panama Canal has brought growth to the region, and we are committed to the prosperity of Panama."



*The well pictured above now supports 100 residences with 500 percent growth capacity—just one of the many wells installed with the newly acquired T3W water well rigs to keep up with a surge in the region's market.*

## Drilling conditions in Panama

Environmental factors weighed heavily in the selection of which rigs and tooling would work best for Panama. Although Panama is a very rugged country, the T3W will go anywhere. The rig had the capability to drill the 1,000-foot-deep (300 m) wells they required with down-the-hole hammers as large as the Atlas Copco Secoroc QL 120.

Much of the drilling is done for community projects. Director of Administration Villegas Arias said the well shown under construction in the photograph was typical of the wells being developed in this project. It was designed to meet the needs of 100 residences, with a growth capacity to 500. The plan, he said, was to provide clean water to all communities in Panama with wells such as this one.

Chief of Drilling Ivan Cedeño said the minimum water flow they want to



Workers near completion of the numerous wells of an IDAAN initiative talk with Nancy Gaitan, IDAAN Maintenance Manager on site. Geology throughout the area required both mud and air drilling methods to penetrate the various layers of heavy loam and clay, consolidated sandstone and igneous rock.

see on a well is 30 gpm (113 L/min.). Normal procedure involved flow testing the well after drilling and again at 72 hours to ensure consistent performance. The well was also tested after construction to analyze the chemical composition of the water.

Drilling the well was just one part of a larger process. Developers at this site also laid water lines to each home. A 500-gallon gravity tank maintained a constant supply to the village.

Cedeño said the geology throughout Panama required both mud and air drilling methods. This site, 5 miles (8 km) from the Pacific coast, presented a common formation for this region. The surface was a heavy loam to clay above consolidated sandstone and igneous rock.

This particular well was drilled through clay to 60 feet (20 m) and then another 60 feet of consolidated sandstone and rock. The completed well was 130 feet (40 m) deep and 10 inches (254 mm) in diameter, cased with 8-inch (203 mm) PVC.

It was common here to start drilling with mud and a tricone before switching to air. IDAAN purchased Atlas Copco Secoroc tricone bits in 9 7/8- (250 mm) and 12-inch (305 mm) diameters, and DTH button bits in 7 7/8-, 9 7/8- and 12-inch diameters. IDAAN selected Atlas Copco Secoroc hammers for air drilling, including a QL 60, QL 80 and QL 120. The QL gave the agency the best penetration rate and had the longest life of the hammers it tried in this formation.

IDAAN wants to keep all Atlas Copco products on site for the practicality of having just one source for service and support. In addition to drilling consumables, IDAAN purchased parts and service items from Atlas Copco. Atlas Copco also supplied a complete training program and service plans to ensure the drillers got optimum productivity and useful life from the new drills.

## Acknowledgements

*This article first appeared in Deephole Driller magazine issue 3 of 2010.*





# The antidote for arsenic

## Rotary mud drilling prevents mineralized arsenic contamination in Wisconsin wells

Ingestion of mineralized arsenic in drinking water can be harmful even in small amounts if consumed routinely over a period of time. Though treatment systems can make contaminated water sources safe to drink, it is more desirable to prevent contamination. The state of Wisconsin in the U.S. requires water well drillers to use rotary technique with drilling fluid to bore through the arsenic-producing stratum. Drilling fluid prevents air from stimulating arsenic formation. Casing the well permanently isolates deep, uncontaminated aquifers from the arsenic-producing zone. It's working, as this contractor and its fleet of Atlas Copco T3W and TH60 water well rigs prove.



*This residential site's existing well tested at 36 parts per billion (0.04 mg/L)—three times the federal limit. However, tests of this replacement well photographed as it was drilled by Leo Van De Yacht's crew resulted in the finding "None Detected."*

The discovery of inorganic arsenic in Wisconsin's Fox River Valley aquifers in 1987 came about almost by accident, an unexpected result from a routine feasibility study for a proposed landfill northwest of Oshkosh. The mineral content survey showed five of eight wells had arsenic above federally accepted minimums. That prompted the Wisconsin Department of Natural Resources (WDNR) to conduct studies of the cause and extent of the arsenic problem.

WDNR researchers established an Arsenic Advisory Area with a buffer zone over a buried geology called St. Peter Sandstone, which runs from southwest of Oshkosh to just west of Green Bay. Although arsenic has been found in wells throughout the state, the principal zone of concern lies over this formation.

The U.S. Environmental Protection Agency (EPA) classifies arsenic as a carcinogen. Long-term exposure may also cause medical issues such as cardiovascular disease, immunological disorders and diabetes. Drinking water with high arsenic levels may also cause more immediate symptoms, such as stomach pain, nausea, vomiting and diarrhea. The federal government limit for arsenic in potable water sources is 0.010 mg/L, or 10 parts per billion.

Though there are treatment systems for arsenic-contaminated water, it's much more desirable to find water sources that do not require treatment. In the Fox River Valley, the solution wasn't farther away, just further down.

The Leo Van De Yacht Well Drilling company of Green Bay had been keeping up with booming residential and municipal water well needs during

a decades-long population surge in the picturesque real estate of eastern Wisconsin. The company quickly became masters of a state-required technique for getting past the poison to the clean drinking water below. The results have been restoring confidence to landowners and community residents and setting the example for other states, which initiated similar surveys that showed the problem is more widespread than had been thought.

## Arsenic layer

In eastern Wisconsin the highest concentration of arsenic-rich mineralization is present at the top of St. Peter Sandstone layer. The farther down one samples below it, the less contaminated the water. Researchers determined that when drillers got past this aquifer into



a lower aquifer above the Cambrian sandstone bedrock, the water was within acceptable standards. This is now the source that water well drillers in this region target for both public and private wells.

In 2004 the WDNR took several steps to mitigate the problem. They published land charts marked with casing and grouting depth minimums that drillers must comply with. They made it mandatory to report well geography for each well drilled, and they placed restrictions on drilling technique: Drilling must be done by rotary mud only.

Since arsenic is released by the oxygenation of sulfide minerals embedded in the layer, experts believe that the introduction of high volumes of air into this formation during drilling greatly exacerbates the problem. Furthermore, they believe once initial oxidation occurs, the process is self-sustaining and this constant release of arsenic, once triggered, will inevitably find its way to the ground water.

## Water well fleet

The Van De Yacht company's small fleet of Atlas Copco drill rigs included a 1995 Atlas Copco TH60, a 2001 TH60 with a casing hammer mounted at Atlas Copco Milwaukee's Water Well Center of Excellence, and a 2008 T3W. These three rigs have enabled them to handle just about any drilling application within their operating area, including municipal "blended" water wells, elevator ram shafts, larger diameter pre-construction piling and vertical geothermal installations.

Rigs are replaced on a rotating upgrade schedule to ensure the company maintains its competitive edge. The most recent acquisition was a newer version of the T3W. This upgrade features larger sheaves and a redesigned cable tensioner, which extends cable life. Three years into service, the Van De Yacht's T3W cables showed no signs of wear.

## Sealing off the zone

The object of drilling in strata containing embedded arsenic deposits is to do



The Van De Yacht company has a fleet of three Atlas Copco drills: One T3W and two TH60 rigs.

so without unnecessary disturbance, then quickly seal them so that they are not exposed to air and never come in contact with the well's water. Bentonite mud helps a bit, too, as its clay helps seal the walls of the bore from air as it is opened up.

The new guidelines tended to slow water well drilling rates. Prior to 2004 a six-man Van De Yacht crew was drilling more than 500 wells a year per rig, routinely drilling two 300-foot (90 m) wells per day. Their personal best, owner Troy Van De Yacht said, was 1,000 feet (300 m) in one day, using both rotary mud and down-the-hole hammer.

Switching to rotary-mud-only now meant that a single well took up to three days to first drill and case off past the St. Peter Sandstone, and then finish drilling to the pink Cambrian sandstone target.

## Case in point

The well in the accompanying photos is a good example of the company's work in the arsenic advisory area. It was drilled to replace the residential well at that site, which tested at 36 parts per billion (0.04 mg/L)—more than three and a half times the federal limit. The

DNR map specified that Van De Yacht case the hole to 168 feet (51 m) at this site and then drill the well to a total depth of 240 feet (73 m).

Using a 9-inch (230 mm) bit on 4 1/2-inch (114 mm) pipe, the crew drilled, cased and grouted the upper hole one day, then completed the 6-inch (152 mm) lower hole to total depth the following day after a 24-hour cure time for the grout.

As they drilled, he said, they were also required to sample and report the geology of the hole to the DNR's well log. At this hole, the first 50 feet were through clay. From 50 to 120 feet (15 to 36 m) the crew encountered limestone with a penetration rate of 22 minutes per 20-foot (6 m) pipe. At 120 through 240 feet (36 to 73 m) they were into the pink cuttings that identified the arsenic-free Cambrian sandstone, advancing 20 feet (6 m) every 15 minutes.

The results were right on the money. The well was producing 40 gpm (151 L/m) with an arsenic level test finding of "None Detected."

## Acknowledgements

*This article first appeared in Deephole Driller magazine issue 1 of 2011.*





# Best bit for the job



The geothermal loop field was installed alongside the 60-foot (18 m) excavation for the College of Law's new facility. Incidentally, the perfectly parallel bores on the excavation's walls represent the signature line drilling also done by Mid-State with an Atlas Copco T4W but with a 6 1/2-inch bit.

## Geothermal pioneer finds right bit for drilling bad stone

**In difficult sandstone conditions a percussive bit's body not only has to endure the energy transfer of hammer blows into stone but also the continuous abrasion of stone cuttings as they are blasted from the bottom of the hole. Atlas Copco Secoroc's 5 3/4-inch (145 mm) convex bits with hemispherical BH66-grade carbide inserts proved capable of making it to total depth in bores drilled for a geothermal project for a correctional facility's expansion. The bit proved itself again on a second, unrelated geothermal project undertaken by the contractor in less abrasive conditions.**

Mid-State Construction Company in Livingston, Tennessee, U.S., is a geothermal pioneer, having entered the market back in the early 1990s. Mid-State CEO and founder Johnny Coleman had been an early proponent of geothermal in the heating and cooling industry. Today this energy-saving strategy for cooling and heating is widely accepted, and Mid-State routinely installs it for new construction as well as for retrofitted upgrades or rehabilitation projects.

Mid-State's reputation as a regional geothermal leader has kept its drilling division almost continuously in the field on large-scale installation projects, often on multiple sites simultaneously throughout its five-state area of operation. The jobs include high schools and colleges, federal, state and municipal buildings.

The company ensures uninterrupted production at each of its concurrent projects by keeping an up-to-date equipment fleet or those makes and models

it believes are most reliable. Of its 125-piece fleet, 30 units are drilling rigs. Among the larger machines are 12 Atlas Copco T4W rigs and a T3W.

Powerful as these rigs are, their production capability relies heavily on the bit at the bottom of the drill string. In the difficult conditions at the Bledsoe County Correctional Complex near Pikeville, Tennessee, only one bit proved cost effective: an Atlas Copco Secoroc 5 3/4-inch bit with conical carbide buttons on an Atlas Copco Secoroc QL 50 DTH hammer.

## Abrasive conditions

The correctional facility is a medium security prison capable of housing 971 inmates. Operating since 1980 as the Southeastern Tennessee State Regional Correctional Facility, it was renamed and designated the intake diagnostic center for the Tennessee Department of Correction. Just before the changeover,



the site underwent an expansion that allowed it to house another 1,444 inmates. It has one maximum security unit, several medium units, young adult accommodations, a co-occurring component, an annex and a 300-bed women's unit. Climate control comes largely from the geothermal loop field of 580, 5 3/4-inch vertical holes to 500 feet (152 m) drilled by Mid-State.

Crews at the correctional complex site encountered extremely abrasive sandstone within only a few feet of the surface, which continued to 480 feet (146 m). Jason Gentry, project manager for Mid-State, described the complex formation as red, pink and white, with three water seams. The water seams were found to run consistently throughout the field. The sandstone eroded most bits so quickly that competitor brands could not complete the holes they started.

Gary Brown, project superintendent, said the company did have success with diamond bits. While the diamond bits could each manage two holes before they were exhausted, however, they were not cost-effective compared to the Atlas Copco carbides in these conditions. Mid-State purchased 600 of the carbide button bits for this project.

## One hole per bit

Atlas Copco T4W rigs started each hole with a new bit, drilling to total depth. Then drillers retrieved the bit, sharpened it and set it aside for later use in projects with less difficult conditions.

Up to five T4W rigs were in use at a time during the year-long contract. As the T4W rigs were drilling, their electronics simultaneously logged the seams and water voids found in each bore. This precise information allowed grouter Jacob Collins to stop exactly at the voids to pack them with gravel. Otherwise, Collins said, he'd lose his grout. This would waste untold amounts of the thermally-enhanced mix used for this application, since the seams ran throughout the breadth and width of the loop field.

The loops were connected by 8-foot (2.4 m) trenches and then run to an exchange house. Two large pipes exiting the rear of the exchange house will



Top: An Atlas Copco T4 and its partnering T3 worked together to drill a hundred 500-foot holes with an Atlas Copco 5 3/4-inch carbide button bit.

permit auxiliary air conditioning or heating if ever the geothermal loops need to be turned off.

## More cost-effective even in better stone

Mid-State was engaged in several other large geothermal projects during the prison expansion work. On-site at Belmont University in Nashville, the company was using the same Atlas Copco 5 3/4-inch carbide bits. This project was for the College of Law's Randall and Sadie Baskin Center, a 71,000 square foot (21,640 m<sup>2</sup>) facility with a five-level, 500-space underground parking garage.

Brown said the project plans called for 100 bores. These were also drilled to 500 feet with T4W and T3W rigs.

Brown assessed the drilling here to be better than at the prison, as it was in limestone with no sandstone at all. There was very little water and no

voids. Bit longevity on average was 9,000 to 11,000 feet (2,743 to 3,352 m) before changing or sharpening.

## Extending value

Though the bits at the correctional facility had drilled only 500 feet each, Brown said the resharpened bits would see additional duty in Mid-State's quarry projects.

Brown said that such frugality over a bit might seem excessive at first, considering the size of the projects and the expense of the rig and hammer. In the increasingly competitive geothermal market, however, bit choice could greatly influence profit margin, in any formation.

## Acknowledgements

*This article first appeared in Deephole Driller magazine issue 2 of 2011.*





# Diamonds in the rough

## Atlas Copco T3W shines in spite of the harsh arctic climate to keep a world-leading diamond mine dry

Facing demanding conditions of the arctic environment, startup of Russia's Grib diamond mine depended on the reliability of a rugged Atlas Copco T3W water well rig. The rig was selected for the task after a two-year-long vetting period. As drillers became more comfortable operating the T3W water well drill rig and discovered which flushing medium and drill bit combinations worked best, production increased.



In July 2011, AGR had plans to drill 40 dewatering holes, as well as a few monitoring wells.

The Atlas Copco T3W water well rig was hard at work at the Grib diamond mine in the Verkhotina license area of northwest Russia, which lies within the Arctic Circle about 75 miles (120 km) north of Arkhangelsk. The first sign of civilization in this remote, rugged location is upon arrival at the mine camp some three hours after departing Arkhangelsk City.

The Grib Mine diamond deposit, an irregularly shaped kimberlite intrusion known as a "pipe," was first discovered in 1996. Development did not begin until 12 years later, however, due to a legal dispute for ownership, which was won by LUKoil.

The diamond reserve was estimated at 98.5 million carats with a predicted annual production capacity for 3.62 million carats. However, in order to effectively extract the diamonds from the deposit, a large volume of water would have to be removed. Dewatering would continue to be essential for the

mine to remain in production over its anticipated 15-year lifespan.

LUKoil is one of Russia's largest companies and one of the largest privately owned oil and gas companies in the world. It contracted its sister company, Arkhangelskgeolrazvedka (AGR), to dewater the Grib Mine. AGR began research for a machine for the bulk of the dewatering work, relegating their existing 15-year-old Russian model water well drill rig to other tasks.

General Director of AGR Igor Prokudin said his mind was made up when he visited an Atlas Copco T3W in Kuzbass in the eastern region of Russia. For Prokudin, the multiple Atlas Copco branches in the region and throughout Russia were a strong selling point, making his decision to purchase a T3W that much easier.

For a little more than two years Prokudin worked with an Atlas Copco salesman who helped Prokudin at every

step of the vetting process. When deciding which rig to purchase, the salesman and Prokudin took a trip to Siberia to show him how the rig works in some of the world's toughest conditions. Atlas Copco also worked with AGR to calculate different technology parameters for the rig to show how the T3W would work in a variety of geological conditions. When it became clear that the Grib Mine's geological conditions were more difficult in reality than they had originally estimated on paper, Prokudin said working with Atlas Copco became even more attractive.

When Lukoil was finally ready to offer AGR the contract to drill dewatering holes around the mine, AGR was ready to purchase its T3W. AGR began drilling with the T3W in July of 2011 with plans to drill a minimum of 40 dewatering holes as well as a few monitoring wells. This freed AGR's Russian model water well rig for exploratory well drilling around the mine.



AGR believes that the T3W drill rig's efficiency is its greatest asset. One drill operator estimated that the T3W was drilling the 300- to 1,000-foot-deep (100 m to 300 m), 25.6-inch-diameter (650 mm) holes about four times faster than the other rig could drill them.

AGR was using an Atlas Copco QL 120 DTH hammer with Atlas Copco 15-inch (381 mm) spherical bits. The depth of each hole depended on the water-bearing zone location, since the water-bearing zone must first be crossed to pump as much water as possible from the hole.

They were initially drilling three holes to test different technologies, learning how to manage the geological conditions. The goal was to find the right combination of drill bit and flushing medium while using the down-the-hole drilling method on air to depths of approximately 100 feet (30 m), with clay-based drilling fluid as the primary choice, though either foam or mud drilling could be used to complete the holes to depths of 820 to 885 feet (250 to 270 m).

An Atlas Copco XAHS 186 compressor was used for developing the water well after the T3W finished drilling the hole. The compressor was needed to lift cuttings from the hole and remove small fragments of sand that would otherwise wear out the pump in a matter of hours. The compressor was instrumental in the well's development, because it moved excess mud and water from the hole's wall, making the water-bearing zone as productive as possible. This process took between three and seven days. The process was complete when clear water began to emerge from the hole.

Once clear water appeared, the small pipe used to inject air into the hole was removed, and an electric submersible pump was placed in the hole to pump the water on a regular basis. The water-bearing zone was not at a consistent depth throughout the mine. Each location required a different depth of crossing for most efficient dewatering.

One of the more noticeable modifications AGR made to the rig was the side paneling added to protect it from the elements, especially during the winter months. Since the average



AGR's plan for commercial production at the Grib mine are set for 2015. Processing facilities are being designed to handle 5 million tons of ore per year.

temperature in the Arkhangelsk region during the winter ranges from 14 to 20 degrees Fahrenheit (-20 to -6 degrees Celsius) in the beginning of winter down to minus 30 degrees Fahrenheit (-34 degrees Celsius) as the winter season progresses, AGR purchased the T3W cold weather package.

Spring and summer seasons at Grib are much less severe. During this part of the drilling season, the crew removes the side paneling on the rig to enjoy working in the northern Russian wilderness, at least for a few months until winter bears down on the T3W drilling crew again.

While the initial geologic exploration of the Grib pipe was completed in 2009, commercial production was

not anticipated to begin until 2015 or later. Processing facilities constructed at the site were being designed with the capacity to handle up to 5 million tons (4.5 million tonnes) of ore per year. Dewatering services may be required for much longer than 15 years if speculation proves true, as some authorities believe that the Grib pipe may support operations 10 to 20 years beyond its original mining plan.

## Acknowledgements

*This article first appeared in Deephole Driller magazine issue 1 of 2012.*





# Draining saturated ground



Cuttings from the discharge line are captured in a steel box so they can be hauled away or disposed of easily. Attaching the discharge line to the box anchors the line and diverts water away from the work area.

## A simple solution for evacuating rainwater in a high water table location such as the Bahamas

The tropical island nation of the Bahamas receives an abundance of annual rainfall. Since the islands' surface is little more than a meter or two above sea level, there is no adequate storm drainage system. Rainwater must be absorbed into the ground. Drainage wells increase the rate of absorption. One drilling contractor finds the Atlas Copco T2W to be the perfect rig to quickly drill and case these relatively shallow drainage wells.

In the past, water well drill rigs in the Bahamas didn't need great depth or speed. Surface water is fresh, and most potable water for the islands comes from reverse osmosis well systems. Bottled water and water from a 3-million-gallon (11,000 kL) tanker arrives daily. Deeper water wells are not productive, since within 20 feet (6 m) of the surface the groundwater becomes brackish and by 30 feet is completely salt water.

Bahamas Hot Mix (BHM) will complete 60 to 140 of the wells a year, completing one well about every two days for an average of three a week.

As alluded to in its name, the company is the chief supplier of asphalt for the islands and does much of the paving. Drainage wells are necessary in construction projects for roads as well as property development. To stay ahead of its projects, BHM needed more drilling capacity than can be done by cable rigs, which had been previously

used for such work. What started out as an additional service to grading and paving work quickly became a full time occupation of its own. The drill has not stopped in the four years since its acquisition.

Service for the previously-owned rig comes directly from Atlas Copco USA's Water Well Center of Excellence office in Milwaukee, Wisconsin, via phone consultations with Technician Joel Kraft and Parts Manager Steve Matic. BHM drill operator Jimmy McAleenan said that when he needs anything, the Atlas Copco office takes his call. The technician who answers knows what he needs without asking for a part number. This is important to the crew members, who must perform all maintenance themselves.

McAleenan was a shop maintenance foreman before becoming a self-taught-driller. The T2W was an easy platform for him to learn, he said. And the company had never had a major



Joseph "Spike" Mather just finishes hooking the wench line for Driller Vernon "The Bear" Moss to pull back to the pipe trailer.

problem with the rig except for one instance when the seals gave out in the swivel due to the abrasiveness of the rock. Even then, the rig was down just two days, and that two-day delay was caused by the lag in shipping time between the U.S. and the Bahamas.

## Drainage wells

One of BHM's projects entailed drilling 60 drainage wells over a 22-month period. Specifications for the wells required clean holes to 150 feet (45 m). BHM crews drilled 170-foot bore holes to allow space for material caving in slightly while setting casing.

The formation was somewhat unpredictable. Crews would unexpectedly

discover loose rock, voids and caves. McAleenan said wells right next to each other could give completely different results while drilling.

The rock is mostly oolitic limestone, but McAleenan said they also have seen dolomite and some quartz. The most difficult material to drill through was clay-like sand, whose appearance he described as beach sand that when compressed in his fist behaved more like clay.

These sandy zones ranged in thickness. The only way the crew could get through them was to pack it into the drill string and trip out to clean it from the pipe. The zones were usually too thin to justify the time required to change to different tooling or methods.

The method that worked best for BHM was reverse circulation using both 4 1/2- and 7-inch dual wall pipe. The Atlas Copco T2W rig's 750 cfm, 300 psi (21.24 m<sup>3</sup> / 2,068 kPa) compressor provided ample air to raise the cuttings. Cuttings showed a mixed variety of material, from extremely hard, dark-colored limestone to crumbly dead coral and seashells.

McAleenan found that drilling in the limestone formation worked best while rotating anywhere from 80 to 200 rpm. BHM used a tricone bit with ballistic carbide tips to get fairly aggressive cuttings. To use this tricone bit, BHM welded steel across the air opening to choke down the air flow. This kept down chip size. Slowing down feed pressure also prevented the pipe from being crowded with cuttings.

To top the first 60 feet (18 m) of the 16-inch-diameter (406 mm) holes, BHM used 10-inch (254 mm) schedule 40 casing. That took care of the top 60 feet while the bottom 9 7/8-inch (250 mm) hole would remain open. A collection box for water runoff will ultimately be built over each open well. McAleenan said BHM is happy with the T2W and this method of drilling. It only takes about seven minutes to change pipe, which helps BHM maintain the pace it needs to stay ahead of its projects. Since each hole's conditions differ so much, it was not possible for BHM to provide an accurate assessment of penetration rates. One day a hole might be completed in seven hours, but if voids or the sandy clay-like material were encountered, it would take much longer.

Fuel economy of the T2W was an added value. When the rig was working hard, it consumed only 12 gallons (45 L) per hour. Average use, however, was closer to 10 gallons (38 L) per hour.

Finishing the Bahama drainage wells required flexibility, since the hole conditions varied so much. In each case, however, the Atlas Copco T2W was more than enough rig for the job.

## Acknowledgements

*This article first appeared in Deephole Driller magazine issue 1 of 2012.*





# Core drilling with an Atlas Copco TH60DH

**Originally designed as a water well rig, this truck-mounted top drive is a multi-application drilling platform—even for coal seam exploration**

Like all Atlas Copco water well rigs, the TH60DH (deephole) design gives it great versatility. The rig can be used for a wide variety of applications by both diversified contractors and specialty contractors. The TH60DH has been used for geothermal, dewatering, degassing, leaching, coring, reverse circulation, uranium and potash drilling and, as demonstrated here, exploration.



*Driller Pat Reeter uses a sifter to sample the material of the hole in order to determine the rock type in each location. The most commonly encountered materials at greater depths were shale, limestone and coal.*

Western Kentucky, located in the southeastern United States, is known for its ample reserves of coal. Although it might seem unusual to see an Atlas Copco TH60 water well rig at work in a coal mine, Armstrong Coal Company found it valuable in starting up its two new mines.

Armstrong Coal controls more than 300 million tons (272 million tonnes) of proven and probable coal reserves in western Kentucky where they operate five mines, surface and underground.

The company became interested in the exploration and core drilling capabilities of the TH60DH drill rig when it started the expansion in 2011. Armstrong used both rotation motors with a speed of 145 rpm to get its core samples and found the TH60DH was fast enough to get the quality they had been looking for.

Armstrong Director of Engineering Keith Brown said the company is doing exploration drilling to look for normal mining strata, targeting some areas to search for strip faults— anomalies where drilling would not be productive.

Core drilling and the exploration process are imperative to understanding different types of rock conditions, faults and abnormalities that will affect the design of the mine. Sandstone, shale and limestone are the most common rock formations in western Kentucky.

Executive Vice President of Operations Kenneth Allen said Armstrong was particularly focusing on strata to determine the integrity and competency of the underground roof and the overall quality of the coal seam. Armstrong's engineers analyze the coal for ash, sulfur, moisture and BTU content, as well as perform a trace element analysis.

“It is important to know the constituents of the coal for marketing purposes,” Allen said. “We evaluate the floor material to help us size the pillars that support the mine—the softer the floor, the bigger the pillars.”

## Mining in Kentucky

Approximately one month after the TH60DH arrived on site, Armstrong Coal drilled a continuous core for the new mine shaft with the TH60DH in Union County, Kentucky. Once completed, drillers used the TH60DH to bore seven to eight water monitoring wells. This process involved drilling both shallow and deep wells, monitoring both surface water and deep water for at least six months prior to filing an application for a permit to mine. Armstrong Coal also initiated exploratory drilling



to target depths that could be used for the roof, floor and seams at different localities around the location of their future mine. Operators drilled to depths ranging between 270 feet to 1,500 feet (80 to 500 m), depending on the coal seam or slopes being analyzed.

As of August 2012, the TH60DH had drilled more than 20,000 feet (6,100 m) in Union County and logged more than 1,800 hours of drill time. According to Project Manager/Coordinator Steve Kane, the TH60DH was running at 95 to 96 percent availability and had no major issues since it arrived.

### Gaining flexibility

Armstrong Coal was pleased with the versatility of the TH60DH. The greatest benefit of having this rig, Kane said, was flexibility for drilling jobs Armstrong used to contract, saving the company money by doing them itself. Some of these tasks included monitoring wells, drilling holes for the safe rooms and core drilling for the underground, travel way and belt slopes.

Using Atlas Copco PDC or tricone bits, the size of the holes varied from 9 to 12 ¼ inches (230 to 311 mm), with consistent use of 3 ½-inch (89 mm) drill pipe. Armstrong Coal also used bits ranging from 5 ⅞ to 6 ⅛ inches (150 to 155 mm) for grouting once the casing was set. They drilled through the casing, concrete, and then used a 4 ⅞-inch (117 mm) bit to finish drilling the hole. They cased with PVC mostly but used steel when deeper than 1,000 feet (300 m).

Allen said the decision-making process to purchase an Atlas Copco TH60DH for use in a coal mine was simple: Armstrong had had good productivity from its Atlas Copco blast-hole drill fleet, backed with dependable service support. When Armstrong was investigating the use of deephole drills, the Atlas Copco TH60 appeared to have exactly what Armstrong required, Allen said, and it was a brand they were comfortable with.

The other Atlas Copco drill rigs in Armstrong Coal's fleet were three Pit Viper 275 rotary blasthole drill rigs, three DML blasthole rigs and two ROC F9 top hammer drills. The company



Ricky Hawes (left) and Pat Reeter (right).

also uses Atlas Copco bits for a number of projects.

The ability to take core at 1,500 feet (460 m) was important to Armstrong. Armstrong Coal doesn't need auxiliary air, even at those depths.

Kane was also adamant about having at least 50,000 pounds (220 kN) of pullback capacity. "We wanted something that had a lot of pullback power and with the TH60DH, of course we've got 70,000 pounds (310 kN) of pullback in case we get in trouble. We felt that with the versatility, we could make the TH60 do what we needed to do with everything we were involved in."

### Future plans

Drilling of exploratory holes continues to determine the best locale and structure for the new underground mine. Once all exploratory holes are completed for this project, the TH60DH will

begin drilling safe-room holes, which are required for underground mines in case of disaster.

"We have to provide so many days of water, so many days of food, oxygen tanks, but also you have to have a surface hole coming all the way down and into that room so you can use it to drop communications, more food, more water," said Kane. "As soon as the undergrounds get progressed enough to need those, then we'll be putting those in, too." Kane said the TH60DH will be drilling a 10 ⅞-inch (270 mm) hole and setting 8-inch (203 mm) casing.

Kane is confident the TH60DH can handle the job no matter what project comes up for Armstrong Coal.

### Acknowledgements

*This article first appeared in Deephole Driller magazine issue 2 of 2012.*





# The water below

## Thirsty Ethiopians have only one direction left to go for water—down.

While Ethiopia may not have plentiful aquifers, it does have groundwater. Experts continue to regard accessing these aquifers as the best way—in some locations, the only way—to meet water demands. Groundwater has the lowest construction time, least capital outlay, lowest impact on aquifer quality and quantity and greatest drought resilience. Drilling rigs such as the T3W water well and T3WDH deep-hole water well models, as well as the highly mobile TH10, are hammering out what often tend to be difficult wells in fractured rock conditions. The versatility of the T3W rigs allows drillers to shift from air to rotary as needed. Coupled with well and water supply education programs and with agreements that give local constituents ownership and care of the wells, the real shortage might only be the pool of skilled drillers.

Ethiopia is urgently pursuing ways to increase its water supply. Surface water sources are scarce in the land-locked country of mountains, arid deserts, agricultural plains and eroded ravines, forcing it to get its water from underground. Yet the difficult rocky soil conditions have traditionally only permitted a few wells, sometimes at great distances from those who rely on them. Further complicating matters, the recent trend toward urbanization has shifted the nation's water priorities toward supplementing overburdened municipal wells, pitting urban necessity against agricultural demand to water crops and livestock, which continues to rise as the country's farms



*A drill rig like this TH10 always draws onlookers in Ethiopia where people still must walk to get water for their daily needs.*

strive to feed Ethiopia's 80 million-plus population. That means Ethiopia needs dependable equipment to tap aquifers in challenging drilling locations. Atlas Copco rigs and drilling tools are providing a reliable solution. Whether they are used by companies working government contracts or by private organizations providing relief services, Atlas Copco drill rigs have been turning the traditional woman's ritual of carrying back a day's water from sources far from home into a nostalgic story to be told by the elderly to their grandchildren.

## Government water well drilling

Oromia Water Works Construction Enterprise (OWWCE) is Ethiopia's administrative government agency responsible for water projects in the

Oromia Region. It is both a drilling and construction company focused on water projects. OWWCE uses its Atlas Copco T3W rigs to drill large-diameter water wells because they can get to the most difficult locations, often where there are no roads.

Much of the Oromia region is mountainous with fractured shale, basalt and sandstone. The water is generally sourced in the sandstone strata. Ninety percent of the drilling is done by air hammer, but 10 percent is mud drilled in sand, gravel or alluvial sedimentations. A driller has to be alert to formation changes at any time.

Unlike private or non-governmental organizations drilling in Ethiopia, OWWCE will work a water project from well through delivery. OWWCE also does large scale commercial projects such as dams and municipal water systems. Of the more than 2,000



Along with the Atlas Copco T3W, crews use Atlas Copco down-the-hole hammers and a tricone bit when necessary.

employees, 237 work in the drilling segments of the business.

The Ethiopian government commissions up to 400 wells annually. Of nearly 240 wells that were commissioned by Oromia's regional government in 2012, 53 were awarded to OWWCE. The agency can have seven drills working at any one time, but for the deep and large diameter work it uses the Atlas Copco T3W rigs. Its fleet includes one each of the 30,000, 50,000 and 70,000 pound (135, 220 and 311 kN) pullback machines. The rigs use 900 or 1070 cfm, 350 psi (425, 505 L/s, 24 bar) onboard air for all drilling.

The T3W works well for OWWCE because of its mobility in the rough terrain, but also because it has a deck engine. OWWCE drilling manager Kumo Kedir said they put excessive time on the drive engine and he doesn't want to overwork the deck engine, since driving from one site to another could take days. Also, the crew could be set up at a hole for 10 to 15 days drilling. Having a second engine balances out engine usage.

## Hole construction

OWWCE often drills with a 21-inch (530 mm) tricone bit, cementing with 14-inch (355 mm) casing to 20 feet (6 m) using an Atlas Copco QL80 DTH hammer and 12-inch (300 mm) bit and case with 10-inch (250 mm) steel production casing. A 17-inch (430 mm) tricone to 650 feet (200 m) will be used as the formation or design calls for it. Occasionally OWWCE will drill a deeper telescoping hole if the conditions call for it. After setting 10-inch casing, OWWCE continues with an 8-inch (200 mm) bit and cases with 6-inch (150 mm) casing.

They always use welded casing for its strength and integrity.

## Challenging projects

The water well projects that the Ethiopian government selects for OWWCE are in the most difficult environments and situations, Kedir said. For example, they often work in Oromia lowland areas, including the

borders of Oromia Somali, Kenya and South Sudan. These countries have been in turmoil and civil war for years. The government has difficulty getting contractors to bid on drilling projects near border towns.

"We go where others won't," Kedir said. "That's just what we do."

In addition to political hostility, the formations themselves in these locations also present difficulties. Trying to bore wells in the broken formations using mud and air drilling methods requires advanced skills. Kedir said OWWCE often gets tasked to drill where independent contractors don't have the skill level necessary.

OWWCE's drillers have years of experience. Its crews live with the drill rigs, moving the camp from one drill site to the next with the rig.

"We fill the gap," Kedir said. "We do what others won't or can't."

## Commercial contractor

KLR is owned by Hagbes PLC, Atlas Copco's distributor in Ethiopia. This





relationship works well for KLR because Hagbes offers services and maintenance capabilities to the smaller company. Currently Hagbes has three service facilities in Ethiopia, but only one is dedicated to rig maintenance. Hagbes's Sales and Marketing Manager Abayou Sitotaw said Atlas Copco rigs are larger than other brands commonly sold in Ethiopia. Hagbes supports all brands with tooling and compressor needs, too. Hagbes Sales Engineer Dejene Adugna said there are lots of companies selling consumables, but Hagbes offers Atlas Copco quality products that customers see as a value for both reliability and cost. "Often our customers are drilling long distances from population centers. If you're 400 miles (640 km) from Addis Ababa, it's important to have quality," he said.

In addition to maintenance technicians, Hagbes' ownership helps KLR with other professional services such as logistics, procurement and accounting so the company can focus on drilling. KLR drilling Supervisor Mulgeta Banteyirga said his group has a focused goal—drilling. "We need to concentrate on the target and do what we can. Our goal is to be a successful leader in the drilling business in Ethiopia." KLR Ethio Water Well Drilling PLC opened for business in 2005 with the intention of becoming a new player in the water well drilling business in Ethiopia. As KLR's General Manager Fekadu Debalkie Alemayehu put it, "There's a lot of opportunity here."

Fekadu said, "We are a country of 80 million people. Of those, 85 percent are farmers." A drive through the country presents one farm after another, closely knit family units of thatched-roof huts. Many homes are surrounded by happy children playing and people working outside in year-round pleasant weather conditions. Yet corporate mega-hectare farms have a strong presence in Ethiopia as well, all vying for the same water supply.

"It rains here three months of the year," Fekadu pointed out, "so we have abundant ground water. We've got plenty of water both for farming and for the people." KLR purchased two Atlas Copco T3WDH drill rigs, each with 70,000 pounds of pullback (95 kN). The



*The increased effort to drill more wells in Ethiopia will mean fewer people have to walk long distances carrying water for their daily needs.*

T3WDH gives KLR the mobility to go wherever needed, whether over improved road surfaces or off-road through rural landscapes. It also has the strength to bore deep, large diameter, large capacity wells. Most of the work the company is doing is in the 656-foot (200 m) depth range.

Fekadu defines three types of water wells needed in Ethiopia. First are shallow wells in the 330- to 490-foot (100 to 150 m) range that are mostly hand-pump wells or small, rural wells. These are for private customers, though primarily on government or non-governmental organization contracts.

Second are the mid-sized wells in the 490- to 985-foot (150 to 300 m) range for commercial, agricultural, industrial and municipal use. Last are deeper wells in the 985- to 2,620-foot (300 to 800 m) range. The deepest municipal water well is a 1,970-foot (600 m) well in Addis Ababa. Though the government is looking for large diameter irrigation wells, too, KLR has been working mostly municipal water well contracts. Various cities throughout

the country will have an average of two wells, but some have up to 14. In the last year and a half KLR has drilled 49 wells of a 71-well contract it needed to finish before the annual rains began. The rains would end their drilling season. Although the specifications change slightly with the geology, well design was uniform. The top 32 feet (10 m) of the profile is drilled to 17-inches (432 mm) diameter and cased with 14-inch (355 mm) casing. KLR uses tricone bits for this and has a variety of cutter styles on hand to fit the formations. The holes are drilled to total depth at 12 inches diameter with an Atlas Copco QL80 hammer and carbide button bits. Then they cased with 8-inch (203 mm) steel casing. KLR water wells average a flow rate of 8 gallons per second (30 L/s). In the driest regions in the north of Ethiopia the flow rate can be as low as 4 gallons per second (15 L/s) in these 12-inch (305 mm) wells.

KLR Operations Manager Ourgie Zeleke said he doesn't see a slowdown in business anytime soon.



The T3W is shown drilling in the Oromia region.

## Church mission

The Ethiopian Kale Heywet Church (EKHC) Integrated Water and Sanitation Program brings water to local communities and educates them with proper sanitation processes. This program is funded through the church by donors such as Tearfund UK, Tear NL, Evangelische Entwicklungsdinet (EED), Tearfund Australia and Conrad N. Hilton Foundation through Living Water International.

Low-cost technology is favored over high-tech. The group develops surface water resources by training residents to gather rain water and maintain more shallow, hand-dug wells. However, drilling for water is also a part of EKHC's mission. Deep wells are drilled with large rigs for manually operated pumps, which locals maintain. The program educates people on how to handle household waste and teaches basic water hygiene. The program delves into other areas of education such as HIV prevention, domestic animal control and safe food handling, all of which keep communities more healthy. To drill these community wells EKHC's

Hydrogeologist Tesfaye Tessema works with the local government administration and EKHC to establish community development opportunities.

EKHC has owned many drills over the years including its drill of preference, the Atlas Copco TH10 drill rig. The church has also purchased an Atlas Copco XRHS 366 compressor to provide the necessary air-flushing power.

In just the first year and a half that the TH10 was in operation, the organization drilled 64 productive wells. Tessema said it's this speed that is the biggest benefit of the TH10.

The process of establishing a well's location starts with the government and the local community establishing need based on population. Normally, Tessema said, they drill a well to serve about 500 people. In one case, the well was replacing as water source two springs that lay in opposite directions from the village. For years, women had walked about 30 minutes to fill their containers with water from them. In dry seasons these springs would dry up to the point that only one of them was left as a source of water, and the number of people pulling water from

it would increase significantly. A well located in the town would be a tremendous relief from that laborious task. Most of the wells drilled in Ethiopia are air-drilled with only about 10 percent requiring a mud pump. For drilling with air, the preferred tools are the Atlas Copco QL80 and QL60 down-the-hole hammers with 8.5- or 6.5-inch bit sizes (165 or 216 mm), respectively. Although the XRHS provides up to 290 psi (20 bar), Tessema said the depth of holes seldom requires more than 230 psi (16 bar). The XRHS offers up to 784 cfm (370 L/s) at 290 psi and can be dialed down to provide only the amount of air necessary to match requirements for the varying well depths of the Shashemene Oromia Region.

Once the well is drilled, the crew gravel packs the well and moves off-site. Part of EKHC's agreement with the community is that the community must provide the sand and concrete to finish off the hydrant. EKHC's foundation installment crew will finish the site and turn it over to the community. Tessema said paying for sand and concrete is a minor expense, but it is vital for sustainability.

Ownership consists of the nine-person committee formed to maintain the operation of the well and educate the community to its use and benefits. In Africa, domestic duties of the household such as fetching water have traditionally been considered women's work. Having local ownership means men must also get involved with maintenance of the site. Increased stakeholder involvement has traditionally proved the best means of ensuring a communal commitment toward effective stewardship. The committee in charge of the well includes trainers, educators, caretakers and organizers who established the well location and will now keep the well in good condition. The government will continue communicating with this group even after completion to ensure the project's success.

## Acknowledgements

*Original case stories appeared in Deep-hole Driller magazine issue 3 of 2012.*





# Exploring Chile's Norte Grande region with Atlas Copco's RD10+



Atlas Copco RD10+ is designed for deephole RC drilling. With a pullback capacity of 100,000 pounds force (445 kN) it can reach deposits 4,000 feet (1,200 m) deep. The RD10+ features a 755 hp (563 kW) Cummins diesel engine. Drilling is fast and efficient with torque of 10,000 pound-feet (13,560 Nm).

## Reverse circulation specialty contractor uses the compact drill rig to locate metal resources

Producing more than one-third of the world's copper supply, Chile also has an abundance of gold, silver and iron. Mining companies are always exploring new ground to locate these precious resources. Most often these corporations contract exploration services through specialists such as PerfoChile, experts in reverse circulation drilling with Atlas Copco RD10+ drill rigs.

Chile has an economy in large part driven by the mining sector. While multinational corporations generally own and operate the mines, mining also supports a number of smaller companies that provide services large operations prefer to contract such as exploration. PerfoChile is an independent exploration contractor, and its rig of choice for the job is Atlas Copco's RD10+.

PerfoChile was founded in 1984 by Osvaldo Carmona Vergara, a former mine superintendent just outside of Santiago. After the mine that he worked for closed, Carmona founded his own contracting business. To get started he purchased a T4BH at another closing mine's auction. Having worked with the rubber-tired blasthole drill in the past, Carmona was pleased with the output the T4BH offered. Initially, Carmona was contracted to drill blastholes for

production in large-scale mining. He later decided to specialize in reverse circulation (RC) air drilling and diamond-core drilling in the mines.

Today PerfoChile is known for RC air drilling, blasthole drilling, and service work with shops based in Santiago, Antofagasta and Pozo Almonte. Most of the company's contracting jobs are in northern Chile. The company has drilled more than 23 million feet (7 million m) since Carmona started the business nearly 30 years ago.

In addition to their fleet of RD10+ rigs, PerfoChile has three T4BH rigs and one T5BH. The drills are all used for exploratory and production drilling contract jobs.

The majority of exploration contractors in Chile focus on core drilling, which is a much slower process than RC drilling. The two methods are similar,



but have differences. The speed of RC makes it ideal for the earlier phases of exploration. RC method also tends to be more cost effective.

PerfoChile typically drills between 1,000 to 2,300 feet (300 to 700 m) depth for their customers. Every job is different, and depending on the terrain, drillers may have to drill different depths for each hole. Operation Manager Osvaldo Carmona Morales said there was no defined pattern for exploration drilling. Sometimes holes were 1 kilometer apart and other times 500 meters apart, according to the instructions of the customer's geologist.

Customers analyze the samples. While PerfoChile's drillers are aware of what's been found in the sample, discussing the findings of a hole is not allowed.

## Exploring northern Chile and beyond

According to Carmona Morales, the RD10+ has had at least 90 percent availability. PerfoChile maintains a tight service schedule to minimize downtime.

With a three-man crew consisting of one driller and two drill helpers, PerfoChile works three shifts per location, including a relief shift. Typically each shift includes time for breaks, set-up and maintenance.

Most jobs consist of eight to 10 holes, typically drilling a total of 10,000 feet (3,000 m) per month. On average each hole will be about 1,312 feet deep.

Carmona Morales said they even hit a total of 16,400 feet (5,000 m) in one month for a customer that needed 10 holes drilled to a depth of approximately 1,640 feet (500 m). Ground and rock conditions determine how quickly and smoothly a job will be in a given location.

Each hole is typically 5 3/4 inches (146 mm) in diameter using a down-the-hole, RC hammer drilling method. Atlas Copco's RD10+ is a hydraulic top-head drive drill that produces 100,000 pounds of pullback (445 kN) and 10,000 pound-feet (13,560 Nm) of torque.

A great majority of Chile's mining takes place in the Norte Grande region.



In 2012, Carmona Morales visited the Atlas Copco Drilling Solutions factory in Garland, Texas, USA.

Within Norte Grande lies the Atacama Desert, a 600-mile (1,000 km) stretch of the driest desert in the world. Average rainfall per year in this region is just 0.04 inches (1 mm). Working in this rugged, remote location requires PerfoChile to set up camp for each job.

The compact design of the RD10+ is beneficial for working in remote locations, Carmona Morales said. He explained that the rig will be used in the mountains but also driven on the highway over long distances, relocating up to 900 miles (1,400 km) between jobs. PerfoChile will send one compressor and booster with the rig, one truck for rods, and another truck for fuel. Trailer campers are included for

remote locations. Although it takes at least three truck loads on average to move from site to site, relocation can be done in a single day.

Globally regarded as expert RD10+ operators and having a strong relationship with Atlas Copco, PerfoChile drillers helped with the setup and training for RD10+ rigs going to other companies, such as one delivered to a customer in Brazil.

## Acknowledgements

*This article first appeared in Deep-hole Driller magazine issue 3 of 2012.*





# Designing a versatile water well rig

**Drillers inspired the Atlas Copco T2W Series III drill rig—small enough for residential jobs yet powerful enough for big-diameter agricultural wells**

Some water well rigs can be either too big or too small to use when their owners try to expand their services. One U.S. contractor teamed with Atlas Copco to design upgrades to its preferred rig model, the T2W. The Atlas Copco T2W drill rig's power combined with its relatively small footprint helped the company hold its own in a struggling water well market, giving access to a variety of jobs beyond the reach of some other rigs.



*The rig is quiet enough even while drilling, owner-driller Wayne Findlay and helper Mike McCall can easily communicate over the rig's single 500 hp engine.*

To update its T2W drilling rig, Atlas Copco met with drillers to learn what improvements were most desirable. Dilden Bros. Drilling of Lafayette, Indiana, has a long history with T2W rigs and welcomed the opportunity to help with the upgrade. Many of Dilden Bros.' preferences are incorporated in the T2W Series III.

Dilden Bros.' co-owners Wayne and Don Findlay depend upon their two T2W drilling rigs to maintain the company's 80-year-old legacy of trusted service to residential, commercial, municipal and agricultural customers. Dilden's rig replacement rotation scheme ensures that there are always two rigs at work funding the latest upgrade.

## T2W Series III features

The T2W Series III upgrade is well suited to the applications Dilden Bros. provides its customers. First, the Series III maintains the characteristic T2W solid boom tower design, which provides ample clearance to perform such work as welding casing. Wayne Findlay, who is in charge of field operations and is chief operator, said he prefers the design because of its less restrictive access to large diameter tools and casings compared to the "caged work area" of lattice-style derricks.

Findlay also appreciates the T2W drill rig's speed, which he attributes to three things: a well-designed, three-speed head; the feed system; and its

rod handling. The feed rate both up and down is 190 feet per minute (58 m per minute).

The rig is available with a variety of air packages. The largest is a 900 cfm, 350 psi (425 L/s, 24 bar) model. It also comes as 750 cfm/300 psi (355 L/s, 14 bar), 500 cfm/200 psi (236 L/s, 14 bar) and no air configurations. Findlay's rig has the 500 cfm/200 psi package.

Findlay also requested an Allison automatic transmission, which is now a T2W option for the no-air and 500 cfm/200 psi packages and is required for 750 cfm/300 psi and 900 cfm/350 psi air models, though Atlas Copco offers a manual transmission for the 750 cfm/300 psi air model as of the first quarter 2013.



Once a 15-inch socket is created in the limestone, Wayne Findlay switches from mud to air to put the QL 120 to work on the Muncie municipal well. With a 15-inch concave bit, rate of penetration was anywhere from 10 to 15 inches per minute in fractured limestone.

Dilden Bros.' rig also has the optional hydraulic front axle assist, which gives the driver near all-wheel-drive capability without raising the truck height. Findlay said they decided to go with super single instead of dually tires on the rear. Other T2W options include mud pumps, pipe spinner, sand reel, water injection and service hoist.

### Geothermal modifications

Though the bulk of Dilden Bros.' business had been water well drilling and installation, in 2008 the company received increasing demand for its geothermal services. Atlas Copco expanded the capacity of the 3 1/2-inch (90 mm) carousel from nine rods to 12 rods. The rig now also allows the driller the ability to backload the carousel from the rod box for uninterrupted pipe handling. Though the carousel was upgraded specifically for geothermal jobs, Wayne Findlay said he had come

to rely on it for many water well applications as well.

Capacity was not the only upgrade to the carousel, which is a swing-in design that brings pipe under the head instead of moving the head to a fixed carousel. The head can still move aside to the right, for instance during case-setting, but alignment is guaranteed over the pipe by a positive stop that ensures that the head always returns exactly to center.

Wayne said the swing-in carousel design is also beneficial during transportation. In its stored position, it centers itself over the truck, balanced down its longitudinal axis rather than to the side of it.

Tom Moffitt, U.S. sales manager for Atlas Copco water well drilling rigs, noted that Dilden Bros.' feedback has been instrumental in making a rig that has always been popular even better. Many of the features Dilden Bros. requested for its rig, Moffitt said, are

standard options now that make the T2W appealing to a wider customer base.

### Large bore capability

Findlay explained that drilling large well bores with air started only as a Dilden Bros. sideline. The capability of the T2W drilling rig to support both wide-diameter rotary mud and large DTH hammers gave Dilden Bros. additional contracts. Though some of Dilden's clients have their own drilling rigs, they tend to be rotary drills, augers and even cable rigs, since most of the drilling in this part of the Midwest generally does not involve much work in rock. When these clients take on large commercial and municipal projects in rock formations, they prefer to subcontract Dilden with its T2W fleet.

The T2Ws have sufficient torque and pullback to drill larger agricultural and municipal wells in any formation in





Dilden Bros.' area of operation. A T2W rig's three-speed rotary head has 12,000 pound-feet (1,627 Nm) of torque at 80 rpm, 8,000 pound-feet (10,847 Nm) at 120 rpm, and 3,500 pound-feet (4,745 Nm) at 275 rpm. With the rig's 410 hp (372 kW) engine, 30,000-pound (133 kN) pullback capability and 15,000-pound (6.9 tonne) hoist, Dilden Bros. had been comfortably boring to 24 inches (610 mm) as part of its normal well services repertoire for six years without any trouble.

Findlay said drilling up to 15-inch (380 mm) diameter bores on air with the T2W evolved incrementally. Dilden Bros. had initially acquired an auxiliary compressor to assist the rigs with an 8-inch (203 mm) hammer. The compressor, though, gave Dilden Bros. the power to run larger hammers, which led eventually to a 12-inch (300 mm) QL 120 hammer.

With the T2Ws, Dilden Bros. can combine rotary and air techniques on the same job, as the following two cases illustrate.

## From residential to wide-bore agricultural well

The T2W rig's popularity is due as much to its versatility as it is to its brand reliability. For instance, Dilden Bros.' rig had just been used on a Friday for a 6-inch (150 mm) residential water well. The following Monday, Findlay set up for a large-bore irrigation well. Findlay said that the changeover from small-diameter residential water well to large-bore agricultural water well involved only the need to haul along a pipe trailer and picking up the larger tools he would need from their base in Lafayette before heading to the site.

The irrigation project required two 168-foot-deep (51 m) wells on land that had produced only 3 bushels per acre (188 kg/ha) that season, which was far from enough to justify the cost of planting or harvesting the section. The problem was due to unrestricted drainage. Only two feet of topsoil lay above sand and gravel that ran to 170 feet (52 m) with a static ground water level of 81 feet (25 m). These conditions meant that any rain falling on the field



*On this irrigation well job Dilden Bros. crews switched deftly from 6 5/8-inch pipe on the trailer to 3 1/2-inch pipe on their 12-rod carousel in moments.*

drained too rapidly to fully benefit the crops at the surface.

Dilden Bros. began on the first well, drilling to within 20 feet (6 m) of total depth the first day with a 17 1/2 inch (445 mm) tricone, returning the next day to complete the well to total depth and to set a 20-foot section of 100 slot stainless steel screen at the bottom beneath 12-inch (305 mm) steel casing. The crew backfilled the annulus around the screen with gravel and developed the well with air until it was clean and producing maximum flow. The well was anticipated to produce over 1,000 gallons (3,785 L) per minute.

Cleaning the irrigation well at this site demonstrated the T2W rig's ability to switch quickly and easily from rotary mud to air. It was a simple matter of changing a hose from the mud pump piping to the compressor and switching from the 6 5/8 inch (170 mm) drill pipe to working with the 3 1/2 inch (9 mm) drill pipe that was in the carousel.

## Muncie municipal blended wells

Bastin-Logan Water Services of Franklin, Indiana, subcontracted Dilden Bros. to help with two replacement wells for Indiana-American Water Co., which provides water services for Muncie, Indiana. Although Muncie's primary source of drinking water is actually the White River, Indiana-American discovered that blending groundwater with water from the river prior to treatment results in improved water quality at lower cost for its customers. Blending water this way is preferred to just using groundwater due to the volume it provides. While water wells will produce hundreds of thousands of gallons of water a day, the river can supply millions. Due to projected increases in demand, Indiana-American needed to upgrade several of its aging 8-inch (200 mm) wells. Dilden Bros.' assignment was to drill



two new 320-foot (100 m) well profiles that began at 24-inches (610 mm) in diameter. These were to be cased with 18-inch (460 mm) steel through sand, clay and gravel layers and sealed 3 feet into limestone. Once into limestone, the profile would narrow to 15 inches (380 mm) and continue down to shale lying just past 300 feet (90 m).

The first well drilled by Dilden Bros. on this job already had its head on and its decking constructed. Forty feet (12 m) of 18-inch (460 mm) casing was set 5 feet into limestone, and then it was hammer-drilled to 324 feet (99 m) total depth. The drilling conditions were more difficult in the second well. It had been raining steadily for two days already with the forecast calling for more. Since the site was just a few feet above river level and only a few dozen yards from the bank, any more moisture could threaten completion. Soon the spongy, saturated ground would not support equipment in spite of the number of mats and timbers in place. The crew had to work fast to beat the worsening conditions.

Findlay drilled and cased the top portion of the well on rotary mud and then sent down a stepped tricone starter bit into the limestone bedrock. This was an 18-inch (460 mm) diameter reamer of bit thirds with a 15-inch (380 mm) tricone extending ahead of it. The pilot bit created a perfectly centered rock socket to start the QL 120 with a 15-inch bit. When chip samples from the discharge convinced him the pilot hole was cleanly cut into the limestone, Findlay withdrew the piloting bit and switched the T2W over to air.

Once in the hole, the hammer was followed by two collars, one 12 inches (300 mm) and the other 8 inches (200 mm), to give it about 7,000 pounds (3,200 kg) of weight. Then a sub adaptor connected the lower part of the string to 20-foot (6 m) lengths of 6 3/8-inch (170 mm) pipe.

A veteran driller, Findlay tuned weight-on-bit by ear and string vibration. The 1070 cfm (505 L/s) auxiliary compressor that was boosting the rig's 500 cfm (236 L/s) compressor was set to about 225 psi (15.5 bar). Findlay added water at 4 gpm (15 L/min.). No adjustments were necessary during the

completion of the 15-inch hole to 320 feet.

Twenty-foot (6 m) pipe lengths descended at rates of 20 to 25 minutes each, with drilling progressing at 10 to 12 inches a minute (255 to 305 mm/min) from start to finish. Dilden completed all but 40 feet (12 m) on this second hole by dark and returned to finish it the following morning, just ahead of the rain. Initial estimates judged the wells to be producing at about 800 gpm (3,028 L/min.) each prior to official testing.

Delford Dunn, the Bastin-Logan project manager on the site, said it might have taken Bastin-Logan three to four

weeks to complete a well such as this with its own rigs, which are designed more for loosely consolidated soils. By comparison, in spite of the soggy conditions alongside the river, Dilden spent just three and a half days on this hole on air, start to finish, with its QL 120 hammer and the versatility of a perfectly matched rig capable of this job and more.

## Acknowledgements

*These articles first appeared in Deep-hole Driller magazine in issue 2 of 2012 and issue 1 of 2013.*



### The attraction of an automatic transmission

This is Dilden's third T2W with automatic transmission. Co-owner Wayne Findlay said they had noticed how well their pipe and water trucks worked with automatic transmissions and made a request for it in their 2001 T2W. Though some operators theorize about driveline and rear end fears, Dilden Bros. has had no issues on this rig or a previous model that also had an automatic transmission. Maintenance amounted to changing the oil on schedule. A manual transmission with the same road time would likely have had its clutch replaced.

Dilden Bros.' experience has been that on the open road, the automatic transmission out-accelerates a manual transmission. Gear changes are quick and smooth. In high-drag situations, such as over a soft field, the automatic transmission will upshift and downshift quickly, as opposed to a manual transmission that might come to a stop while the driver shifts gears. Drivers do not need to "ride" the clutch while backing up slowly. In addition, Findlay pointed out, any driver can operate an automatic transmission without prior training or experience in a manual transmission vehicle.

Lyndell Pannell, a fleet account representative for Southwest International Trucks Inc., is a proponent of the Allison automatic transmission. He believes they are safer to drive because the driver is concentrating on the road rather than on operation of the vehicle.

Pannell said that automatic transmissions also increase productivity. The Allison, for instance, has prognostics that tell when it needs service so owners and operators can avoid over- and under-servicing the transmission. The automatic transmission allows the engine to operate at a lower rpm, which results in better fuel economy. Pannell also pointed out that safety features can be programmed into an Allison transmission based on the application. He believes higher initial cost is offset over time by the decrease in driveline and clutch and transmission related failures.





# Star of India

## New technology

As India explores its oil and gas reserves to enhance domestic production, a new technology has emerged for deep well drilling – the Predator Drilling System. Developed by Atlas Copco Drilling Solutions in the U.S., Predator is now helping the Indian oil and gas industry to take drilling performance, energy efficiency and safety to a new level. For a country looking to reduce its dependence on imports of oil and petroleum products by exploiting its domestic natural gas, the latest technology and advanced equipment is critical.

India still predominantly uses conventional methods of exploration and production drilling, which is time consuming and expensive. That's why, when Indore-based contractor Shivganga Drillers Pvt Ltd., was approached by various oil and gas exploration companies, it realized that a significant advantage could be had by adopting the latest technology.

"We were aware that Atlas Copco had done extensive field trials with both mud drilling and air drilling and that its Predator Drilling System incorporated very advanced, new generation technology," says Anuj Rathi, Shivganga's Chief Operating Officer. "We decided it was extremely suitable for this task."

As a result, Shivganga brought the world's first Predator system to India in 2013, and soon after its arrival, the company was awarded a major drilling contract from ONGC (Oil & Natural Gas Corporation Ltd) India's largest oil and gas exploration and production company, to drill a well more than 2 000 m in depth.

## Difficult challenge

However, this project was not as easy as Shivganga initially thought. Located in the interiors of central India, the site

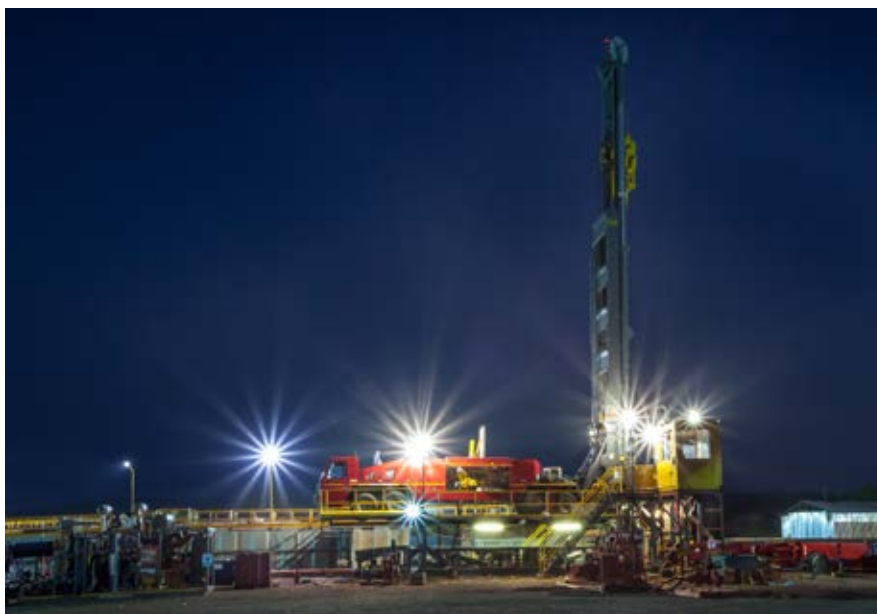

Nightfall at the site: The giant, mobile Predator drilling a gas well more than 2 000 m deep.

posed a major challenge. In most zones, the company encountered sandstone with an abrasiveness of 80–85 percent, mixed with much softer formations making it difficult for the driller to anticipate the hardness of the rock and act accordingly.

"The compressive strength of the formation was fickle, ever-changing and never a constant. When you encounter a formation that changes so fast you need to be very careful and have very precise control over all the parameters," explains Rathi. "Thankfully, the Predator gave us that kind of precision and we were able to keep changing the parameters depending on the requirements. The machine responds very quickly and you can change these parameters instantly."

During the project Shivganga says it achieved a performance of more than 400 m in 18 hours – a speed it believes may be a record in such formations. "We managed to keep our promise and delivered a time saving of 35 to 40 percent," Rathi comments. "Using conventional drilling technology, it would have probably taken around six to eight months to drill this well, whereas

we did it in just two and half months, including field trials, testing, setup and drilling. That's probably never been equalled."

## Outstanding rock drilling tools

Shivganga insisted on full support from Atlas Copco and therefore chose Secoroc DTH hammers and bits for this deep, high pressure, percussive drilling application. Secoroc QL 120 hammers were chosen for the larger diameters (442 and 323 mm) and QL 80 hammers for the final 216 mm diameter finishing section of the well.

The performance of these hammers was unmatched. Perfectly married to the Predator they delivered exactly the desired speed for the depths. The QL hammers also came with additional attachments such as a hydrocyclone and a bit retrieval system, which made them even more efficient. The retrieval system could hold the bit in case of breakage from the shank, and under no circumstances could a bit be lost inside the well, eliminating the need for "fishing" and the risk of having to



abandon a hole. The bits also had buttons specially made with polycrystalline diamonds, on the face and gauge, to make them more aggressive in the hardest rock.

“ONGC was very excited with the progress we made with this rig,” says Rathi. “They were a little skeptical initially about the outcome if we found hydrocarbons, but we managed to finish the work successfully.”

## Safety and environmental impact

The oil and gas industry is both hazardous and environmentally sensitive, calling for the highest levels of safety and health precautions. Any contractor or company aiming to get into Oil & Gas exploration and mining has to follow strict guidelines set by the Director General of Mines Safety. Shivganga was no exception and had to ensure stringent safety and environmental norms when carrying out the drilling work. In this respect, the energy efficient and environmentally friendly design of the Predator gave Shivganga an added advantage in negotiating the contract.

“The Predator consumes less diesel and requires fewer oil changes in comparison to other drilling systems,” says Rathi. “The level of emission and sound pollution is also extremely low for the rig. In fact, it’s way below the permissible limits in India.”

Another big plus point was the Predator’s mobility that reduces the rig setup time. “With conventional rigs, it takes roughly two months to mobilize and set them up, whereas the Predator, being a mobile machine, can be set up in a matter of hours. Also, it’s an automated drill so you need less manpower which means there are fewer safety hassles and hazards,” adds Rathi.

Shivganga managed to complete the ONGC contracts in the preset time frame, which enabled the company to win two more drilling contracts in quick succession.

## High quality service and support

One of the company’s main concerns, as a newcomer to the O&G drilling



*Manning the control panel: The Predator completed the targeted depth of more than 2 000 meters on time and with a “best performance per shift” which the company believes is a record in the Indian O&G industry.*

business, was the consequences of not being able to source spare parts in time in the event of a breakdown.

“In the O&G business, once the explorer identifies the well, they set up a timeline for drilling. This is defined in the actual contract and the job has to be completed within the stipulated time period. If the work goes beyond that, a penalty has to be paid by the contractor,” adds Shivganga’s Director

B L Rathi, who has three decades of experience in water well drilling before entering the O&G business.

“We took this challenge and the risk because we felt confident that Atlas Copco could support us as they have been in India for so many years. All of the promises made to us during the purchasing process, right from providing adequate backup to bringing engineers from abroad to support us and train our people, were fulfilled satisfactorily. Their response was fast, they listened to our problems and attended to them very quickly.”

## Working to improve

Mukul Bahety, Chief Executive Officer at Shivganga, explains that the company is now working to make the Predator even better. “We are in a learning phase, understanding the opportunities that an advanced system like the Predator can offer and are working together with the Atlas Copco team to further improve the machine’s performance.” He concludes: “Overall our customer, ONGC, as well as ourselves, are extremely satisfied with the Predator. I see this rig having a huge future in India and I anticipate that the Predator population in this country will go to at least eight or ten within the next five years.”

## Acknowledgements

*This article first appeared in Mining and Construction magazine Vol. 2 of 2014.*





www.atascopca.com

hurricane  
PROTECTOR





# Lightweight water well

Atlas Copco's range of lightweight water well drill rigs have been designed to withstand aggressive, rugged environments with minimal maintenance in the remotest regions of the world. Hydraulically powered through a deck engine, the flexibility of the range ensures a multipurpose top-head drilling rig designed to drill water and bore wells using mud rotary, air and down-the-hole hammers. The lightweight series includes the TH5, TH10, TH10 LM for rotary and DTH drilling, ranging from 2,270 kg to 12,000 kg (5,000 lb to 26,455 lb) of pullback.

TH5		
Pullback	2,270 kg	5,000 lb
Pulldown	1,364 kg	3,000 lbs
Rotary Head Torque	92 kgf m	8,000 in lbf
Rotary Head Speed	0 to 100 rpm	0 to 100 rpm
Module Option	Yes	
Mud Pump Option	Yes	
Water Injection Option	Yes	
Breakout Wrench	Manually operated	
DHD Lubricator	Yes	
Winch	No	
Deck Engine	Yes	
On-board Compressor	No	

TH10		
Pullback	6,818 kg	15,000 lb
Pulldown	4,080 kg	9,000 lb
Rotary Head Torque	518 kgfm	3,750 ft lb
Rotary Head Speed	0 to 85 rpm	0 to 85 rpm
Module Option	Yes	
Mud Pump Option	Yes	
Water Injection Option	Yes	
Breakout Wrench	Yes	
DHD Lubricator	Yes	
Winch	No	
Deck Engine	Yes	
On-board Compressor	No	

TH10LM		
Pullback	12,000 kg	26,455 lb
Pulldown	7,000 kg	15,432 lb
Rotary Head Torque	518 kgfm	3,750 ft lb
Rotary Head Speed	0 to 85 rpm	0 to 85 rpm
Module Option	Yes	
Mud Pump Option	Yes	
Water Injection Option	Yes	
Breakout Wrench	Yes	
DHD Lubricator	Yes	
Winch	Yes	
Deck Engine	Yes	
On-board Compressor	Yes	

Visit [www.atlascopco.com/wwdrills](http://www.atlascopco.com/wwdrills) for more information









# T2W-III

More features were designed into the T2W than any machine in its class, providing the benefits of larger, more expensive drilling rigs. With its open work area, excellent control of feed speed and exceptional on and off road mobility, the T2W is not only perfectly suited for water well drilling but also for a wide variety of environmental, air rotary and DTH drilling. The Atlas Copco T2W is a lightweight, truck-powered water well drill designed for air/mud applications.

Technical Specifications		
Pullback	30,000 lbs	13,607 kg
Pulldown	30,000 lbs	13,607 kg
Rotary Head		
Option 1	2 motor spur gear tophead, 3-speed	
	12,000 ft-lb @ 0 to 80 RPM	
	8,000 ft-lb @ 0 to 110 RPM	
	3,500 ft-lb @ 0 to 275 RPM	
	2 1/2 inch Spindle ID	
*Hydraulic valve		
Option 2	8,300 ft-lb @ 0 to 85 RPM	
	6,213 ft-lb @ 0 to 119 RPM	
	2,850 ft-lb @ 0 to 255 RPM	
	*2 5/8 inch Spindle ID	
*Both options have hydraulic off-hold slide to the right		
Hoisting System		
Standard	12,000 lb / 150 ft/min	95,443 kg / 45.7 m/min
Option	15,000 lb / 146 ft/min	6,803 kg / 44.5 m/min
*2 part winch line for Main Hoist		
Main Hoist, integral brake	8,000 lb / 85 ft/min	3,629 kg / 35.9 m/min
Aux Hoist, integral brake	4,000 lb / 120 ft/min	1,814 kg / 36.6 m/min
Sandreeel, Without clutch	2,000 lb	907 kg
Compressor		
500 cfm/200 psi (236 L/s / 14 bar)		
750 cfm/300 psi (354 L/s / 20 bar)		
900 cfm/350 psi (425 L/s / 24 bar)		

Option
Water injection
On-board mud
Hydraulically operated off-board mud piping
350 Gallon Swing up mud pit with Moyno grout pump
Floating sub spindle
DHD lubricator
Single rod loader (cannot be used with carousel)
Pipe spinner
6x6 hydraulic front drive
Larger rod box (cannot be used with carousel)
Automatic Allison transmission

Visit [www.atlascopco.com/wwdrills](http://www.atlascopco.com/wwdrills) for more information









# TH60 & TH60 DH

With up to 600 hp (477 kW) under the hood and 1,850 ft-lb (2,508 Nm) of torque to the rear wheels, the TH60 moves along at highway speeds, delivering the power to move in mountainous locations without continuously downshifting, as well as ample torque throughout its range of gears on the jobsite. The single engine configuration reduces overall rig weight and improves weight balance. Reduced noise and deck congestion make service and maintenance easier. The TH60DH is a mid-weight, truck-powered, hydraulic tophead drive drill rig. It is designed for water well and other applications requiring air or mud rotary and downhole hammer drilling methods. The drill is suitable for drilling 5 to 12 in (127 to 305 mm) holes but can drill up to 20 in (508 mm) and handle up to 19 in (483 mm) diameter casing.

Technical Specifications TH60		
Pullback	40,000 lb	18,144 kg
Pulldown	25,000 lb	11,340 kg
*Option of 30,000 lb pulldown		
Drawworks - Single Line Bare Drum		
Standard	18,000 lb 165 fpm	8,165 kg 50 m/min
Optional	30,000 lb 150 fpm	13,608 kg 45 m/min
Compressor		
900 or 1070 cfm/120 to 350 psi (425 l/s or 505 l/s / 8.3 to 24.1 bar)		
*900 CFM only available on export TH60		

Technical Specifications TH60DH		
Pullback	70,000 lb	31,751 kg
Pulldown	30,000 lb	13,608 kg
Drawworks - Single Line Bare Drum		
Standard	18,000 lb 165 fpm	8,165 kg 50 m/min
Optional	30,000 lb 150 fpm	13,608 kg 45 m/min
*2-part line taking 30,000 lb winch to 60,000 lb		
Compressor		
1070 cfm/120 to 350 psi (505 L/s / 8.3 to 24.1 bar)		

Rotary Head TH60 / TH60 DH		
Standard at 145 RPM, single-speed rotary head	5,500 ft-lbf	7,458 Nm
Optional at 145 RPM, two-speed rotary head or Optional at 195 RPM, Second Speed	5,500 ft-lbf or 4,000 ft-lbf	7,458 Nm or 5,424 RPM
Optional at 134 RPM, single-speed rotary head	6,250 ft-lbf	8,475 Nm
Optional, at 134 RPM, two-speed rotary head or Optional at 180 RPM, Second Speed	6,250 ft-lbf or 4,650 Nm	8,475 Nm or 6,310 Nm
Optional at 105 RPM, single-speed rotary head	8,000 ft-lbf	10,848 Nm
Optional, at 105 RPM, two-speed rotary head or Optional at 145 RPM, Second Speed	8,000 ft-lbf or 5,500 ft-lbf	10,848 Nm or 7,458 Nm

Standard Carrier		
Standard	Peterbilt 367 Cummins ISX	
Standard, at 1800 RPM	600 hp	448 kW
Standard wheelbase	24' 7"	7,493 mm
Standard, GVWR	68,000 lb	30,844 kg
Options TH60 / TH60 DH		
Mud pumps		
Floating-spindle sub		
No-air option		
High-pressure air piping		
Pipe spinner		
Sand reel		
Water injection		
Single-pipe loader		
Service hoist		
DHD lube injection		

Visit [www.atlascopco.com/wwdrills](http://www.atlascopco.com/wwdrills) for more information









# T3W & T3W DH

A combination of old and new technology on the T3W boosts productivity, efficiency and fuel savings while providing the familiarity and reliability you expect from an Atlas Copco drill. The T3W DH is designed to handle larger, deeper holes with larger diameter casing than the standard T3W. With 1070/350 on-board air, 70,000 lb (31,751 kg) pullback and a 20 in (508 mm) table opening, this rig offers contractors an expanded application range and all of the proven T3W operating system advantages.

Technical Specifications T3W		
Pullback	40,000 lb	18,144 kg
Pulldown	25,000 lb	11,340 kg
*Option of 30,000 lb pulldown		
Feed System		
Single Cylinder	Cable Feed	
D:d Ratio, cable	28:1, 7/8"	22 mm
Drill Feed Rate	20 fpm	6.1 m/min
Fast Feed Up/Down	150 fpm	45.7 m/min
Derrick		
Capacity	45,000 lb	20,412 kg
Main Cord Length	36' 6"	11 m
Head Travel	27' 4"	8,330 mm
Width	36"	914 mm
Depth	28"	711 mm
Standard Carrier		
Standard	Navistar 7600, 6x4 Cummins ISX 15	
Standard, at 2100 RPM	450 hp	335 kW
Standard wheelbase	23' 2"	7,061 mm
Standard, GVWR	68,000 lb	30,844 kg
Drawworks - Single Line Bare Drum		
Standard	18,000 lb 165 fpm	8,165 kg 50 m/min
Optional	30,000 lb 150 fpm	13,608 kg 45 m/min

Technical Specifications T3WDH		
Pullback	70,000 lb	31,751 kg
Pulldown	30,000 lb	13,608 kg
Feed System		
Twin Cylinder	Cable Feed	
D:d Ratio, cable	28:1, 7/8"	22 mm
Drill Feed Rate	20 fpm	6.1 m/min
Fast Feed Up/Down	150 fpm	45.7 m/min
Derrick		
Capacity	75,000 lb	34,019 kg
Main Cord Length	36' 6"	11 m
Head Travel	27' 4"	8,330 mm
Width	36"	914 mm
Depth	28"	711 mm

Standard Carrier		
Standard	Navistar Paystar 5600i 6x4 Cummins ISX 15	
Standard, at 2100 RPM	450 hp	335 kW
Standard wheelbase	23' 2"	7,061 mm
Standard, GVWR	68,000 lb	30,844 kg
*2-part line		
Drawworks - Single Line Bare Drum		
Standard	18,000 lb 165 fpm	8,165 kg 50 m/min
Optional	30,000 lb 165 fpm	13,608 kg 50 m/min
Rotary Head T3W / T3WDH		
Standard at 145 RPM, single-speed rotary head	5,500 ft-lbf	7,458 Nm
Optional at 145 RPM, two-speed rotary head or Optional at 195 RPM, Second Speed	5,500 ft-lbf or 4,000 ft-lbf	7,458 Nm or 5,424 Nm
Optional at 134 RPM, single-speed rotary head	6,250 ft-lbf	8,475 Nm
Optional, at 134 RPM, two-speed rotary head or Optional at 180 RPM, Second Speed	6,250 ft-lbf or 4,650 ft-lbf	8,475 Nm or 6,310 Nm
Optional at 105 RPM, single-speed rotary head	8,000 ft-lbf	10,848 Nm
Optional, at 105 RPM, two-speed rotary head or Optional at 145 RPM, Second Speed	8,000 ft-lbf or 5,500 ft-lbf	10,848 Nm or 7,458 Nm
Powerpack T3W / T3WDH		
Option 1	900 cfm at 350 psi - Caterpillar C15 diesel engine, 575 hp (354 kW) at 1,800 RPM. IR HR 2.5 over-under screw compressor, 900 cfm (425 L/s) flow, direct coupled 120 to 350 psi (8.3 to 24.1 bar), optional in/out compressor disconnect	
Option 2	1070 cfm at 350 psi - Caterpillar C15 diesel engine, 575 hp (421 kW) at 1,800 rpm. IR HR 2.5 over-under screw compressor, 1070 cfm (505 L/s) flow, WITH STANDARD IN/OUT BOX. 120 TO 350 psi (8.3 to 24.1 bar)	
* Refer to Atlas Copco for Tier4 final options.		

Visit [www.atlascopco.com/wvdrills](http://www.atlascopco.com/wvdrills) for more information





# T4W

The T4W continues its legacy with chassis and drill enhancements that raise the benchmark of water well drills in the 70,000 lb/31,752 kg class. Standard and optional features provide contractors with additional capacity and improved performance.

Technical Specifications, Carrier	
Export Chassis	6 x 4 Custom, 203 in. wheelbase (Export)
US & Canada	8 x 4 twin steer (U.S. & Canada)
Optional Chassis	6 x 6 all-wheel drive 8 x 4 twin steer Polished aluminum wheels, air conditioning
Derrick	
Dimensions	33' 3" x 46" x 33"
Feed System	
Heavy Duty Chain	
Pulldown	30,000 lb
Pullback	50,000 lb
Optional pullback w/regen	70,000 lb
Drill Feed Rate	11 ft/min
Fast Feed Rate	Up 110 ft/min
Fast Feed Rate	Down 70 ft/min
Rotary Head	
Standard worm Gear	5,983 ft-lb @ 0-109 rpm
Optional Spur Gear	8,000 ft-lb @ 0-110 rpm
Swivel and Piping	
Rated for 350 psi operation	
Swivel I.D.	2"
Piping I.D.	2"
Jib Hoist/Casing Hoist	
Lifting Capacity (standard)	1,250 lb
Optional	2,500 lb
Line Speed	70 ft/min
8,000 lb casing hoist	80 ft/min
Powerpack Selections	
Compressors	1070/350 - 30.3 cu.m <sup>3</sup> /min/2413 kPa 1250/350 - 35.4 cu.m <sup>3</sup> /min/2413 kPa
Cummins' Engines	QSX-15-C - 600 hp @ 1800 rpm QSK-19C - 700 hp @ 1800 rpm
Dimensions and Weights	
Legth, Derrick Down	34' 11"
Height, Derrick Down	13' 10"
Width, Outside Jacks	8'
Weight, Standard Rig less pipe	60,500 lb

Options
Hydraulic indexing cylinder
Collar handling package
Deephole package w/regen
Water injection
Mud pumps
DHD lubrication
Auxiliary fuel tank
Universal pipe handling
Extended derrick
Deck engine starting aid
Water tank
High-torque rotary head

Visit [www.atlascopco.com/wwdrills](http://www.atlascopco.com/wwdrills) for more information







# RD20 II and RD20 III

The RD20 is self-contained, powerful and mobile. Drill functions are hydraulically driven to provide a combination of quick response and precise control. They are designed to deliver maximum productivity while operating as efficiently as possible, even in the most extreme drilling conditions.

Technical Specifications RD20 II		
Pullback	RD20 II	
Carrier		
Custom tandem chassis built to Atlas Copco specifications		
wheelbase	226"	5.7 m
GVWR	86,000 lb	39,010 kg
Powerpack		
Cummins QSK-19C engine, 755 hp / 522 kW at 1800 rpm, IR		
HR2.5 over/under screw air end 1250/350 at 1800 rpm, engine silencer		
Derrick Dimensions		
L x W x D	51' x 1 1/2" x 48 1/2" x 41"	15.6 m x 1.2 m x 1.0 m
Feed System		
Pullback	110,000 lbf	489 kN
Pulldown	30,000 lbf	60.5 kN
Drill Feed Rate	22 ft/min	6.7 m/min
Fast Feed Up (regen on)	141 ft/min	42.9 m/min
Fast Feed Down	176 ft/min	53.6 m/min
Rotary Head		
4SF-2-12 spur gear head, 0-120 RPM, 8,000 ft-lbf torque, Piping: 3 in (76 mm) circulation rated at 1,500 psi working pressure		
Jib Boom & Hoist		
Lifting capacity, bare drum	4,000 lb	1,814 kg
Line Speed, bare drum	100 ft/min	30.5 m/min
Casing Hoist		
Lifting capacity, maximum	7,500 lb	3,402 kg
Line Speed, maximum	60 ft/min	18.3 m/min

Technical Specifications RD20 III		
Pullback	RD20 III	
Carrier		
Custom tandem chassis built to Atlas Copco specifications		
wheelbase	281"	7.1 m
GVWR	113,000 lb	51,364 kg
Powerpack		
Cummins QSK-19C engine, 755 hp / 522 kW at 1800 RPM, IR		
HR2.5 over/under screw air end 1250/350 at 1800 RPM, engine silencer		

Derrick Dimensions		
L x W x D	61' x 11 1/2" x 48 1/2"	18.9 m x 1.2 m x 1.0 m
Feed System		
Pullback	120,000 lbf	489 kN
Pulldown	30,000 lbf	60.5 kN
Drill Feed Rate	29 ft/min	8.8 m/min
Fast Feed Up (regen on)	106 ft/min	32.3 m/min
Fast Feed Down	180 ft/min	54.9 m/min
Rotary Head		
4SF-2-12 spur gear head, 0-120 RPM, 8,000 ft-lbf torque, Piping: 3 in (76 mm) circulation rated at 1,500 psi working pressure		
Jib Boom & Hoist		
Lifting capacity, bare drum	4,000 lb	1,814 kg
Line Speed, bare drum	225 ft/min	68.5 m/min
Casing Hoist		
Lifting capacity, maximum	7,500 lb	3,402 kg
Line Speed, maximum	106 ft/min	32.3 m/min
Options RD20 II / RD20 III		
Collar-handling package		
Drill pipe carousel		
Water injection		
Hydraulic table levelling jacks		
Compressor disconnect		
Mud manifold		
DHD lube		
CAT C27 800 hp Deck Engine		

Visit [www.atlascopco.com/RD20](http://www.atlascopco.com/RD20) for more information





# RD20 XC

The RD20 is self-contained, powerful and mobile. Drill functions are hydraulically driven to provide a combination of quick response and precise control. They are designed to deliver maximum productivity while operating as efficiently as possible, even in the most extreme drilling conditions. RD20 XC handles oilfield external upset "Bottleneck" drill pipe: 2 7/8" to 4 1/2" OD, Range 2 lengths.

Technical Specifications, Rig Performance		
Hookload	120,000 lb	54.4 tonnes
Pulldown	30,000 lbf	13,636 kg
Fast feed up	106 ft/min	32.3 m/min
Fast feed down	180 ft/min	54.9 m/min
Drill feed	29 ft/min	8.8 m/min
Torque	8,000 lbf-ft	10.8 kNm
Speed	0-120 RPM	0-120 RPM
Spindle	3"	76.2 mm
Swivel Type	Multi chevron packings	
Opening	2 1/2"	63.5 mm
Carrier		
Twin H-beam main frame - reinforced	16"	406.4 mm
5-axle, custom carrier	425 hp	317 kW diesel engine
8-speed transmission	Manual with lo - lo and reverse	
Tridem rear axles with lockers	23,000 lb	10,433 kg each
Tandem front steering axles	22,000 lb	9,979 kg each
Derrick		
Length	61 ft 11 1/2"	18.88 m
Width	48 1/2"	1.23 m
Depth 41 in	1.04 m	
Top of table to spindle	51' 6"	15.7 m
Table to ground (rig sitting on tires)	44"	1,118 mm
Table to ground (jacks fully extended)	92"	2,337 mm
Rig Dimensions		
Height derrick down	13' 10"	4.22 m
Height derrick up	62' 6"	19.05 m
Width	8' 4"	2.54 m
Shipping weight (less tooling)	88,000 lb	40,000 kg
RD20 XC Unique Specifications, Tip out Links		
Forged steel	150 ton	136 tonnes
Length	60"	1,524 mm
Tip out	hydraulic cylinder on each link	
Angle	0-90° from vertical	
Control	driller's console	

Table & Master Bushing		
Design	folding with twin hydraulic jacks	
Max opening	26"	660 mm
API split master bushing	17 1/2"	445 mm
Capacity	60 ton	54.4 tonnes
High Torque Make Up & Break Out Wrench		
Type	petol chain wrenches hydraulic cylinder actuated flip-over wrench heads	
Wrench Torque	50,000 lbf-ft	67.8 kNm
Adjustable size range	3 to 8 1/4"	76-210 mm
Height adj. BO	13"	330 mm
Height adj. MU	13"	330 mm
Control	driller's console	
Circulation Manifold		
Capacity	3,000 psi	206.8 bar
Diameter	3"	76.2 mm
Main valve	hydraulically actuated	
Mixer line	manually actuated	
Pressure gauge in line		
Air/Mud hose	3"	76.2 mm
Capacity	3,000 psi	206.8 bar
Circulation Manifold - Air		
Capacity	1,500 psi	103.4 bar
Diameter	2 1/2"	63.5 mm
Main valve	hydraulically actuated	
Blow down	electrically actuated	
Isolation valve	manually actuated	
Aux. comp. in	2 1/2"	63.5 mm
To Booster	3"	76.2 mm
From Booster	2 1/2"	63.5 mm
Air/Mud hose	3"	76.2 mm
Capacity	3,000 psi	206.8 bar
Elevators		
Forged Steel	100 ton	90.7 tonnes
Size	2 7/8 - 5"	73 - 127 mm
Actuation	hydraulic cylinders open/close & lock	
Control	driller's console	

Visit [www.atlascopco.com/RD20](http://www.atlascopco.com/RD20) for more information





# Automatic Pipe Loader

Designed exclusively for the RD20 or RD20 XC, Automatic Pipe Loader (APL) is a reliable, hands-free pipe-and-casing handling system that has a major impact on enhancing efficiency, safety and performance during the drilling process. APL is a skid-mounted load that is simple to mobilize and rig up. A wireless control module and hands-free operation reduce manual labor, enhance efficiency and reduce pipe-handling time and cost.



Technical Specifications		
Length	50.4'	15.3 m
Width (transport)	8.5'	2.6 m
Width (drilling)	20.6'	6.2 m
Height	4.7'	1.4 m
Weight	35,000 lb	15,875 kg
Pipe Handling Size Range		
Outside diameter	3 1/2" - 13 3/8"	88.9 - 339.7 mm
Length	28' - 45'	8.5 - 13.6 m
Maximum pipe weight	6,000 lb	2,727 kg

Powerpack - Self contained skid		
Electric motor, totally enclosed fan cooled	100 hp	75 kW
	50/60 Hz at 230/460V	50/60 Hz at 230/460V
Hydraulic Output	64 gpm at 3000 psi	242 lpm at 207 bar
Remote Controller	Class 1, Division 1 wireless radio remote, lightweight and weatherproof	

Visit [www.atlascopco.com/oilandgas](http://www.atlascopco.com/oilandgas) for more information





# Predator Drilling System

The Predator Drilling System is a unique package that applies innovation and proven new technology to exploration and production drilling. With a 30 year history and an experience-base of over 300 rigs in the global oil patch, Atlas Copco's Predator brings a new generation of design that reduces non-drilling time and cost, improves performance and energy efficiency and enhances safety. With its 200,000 pounds of hookload, Predator has the strength and capacity to drill vertical, directional and horizontal wells to depths of 8,000 feet in today's global oil, CBM and natural gas basins.

Technical Specifications		
Hook Load Capacity	110 ton / 220,000 lb	100 tonnes / 100,000 kg
Top Drive - hydraulic power		
High torque range	30,000 lbf-ft @ 0-90 rpm	40.7 kNm @ 0-90 rpm
High Speed range	15,000 lbf-ft @ 0-180 rpm	20.3 kNm @ 0-180 rpm
Spindle ID	3" or 5"	76.2 mm or 127 mm
Additional features	0-90° tip out with lock replaceable swivel cartridge directional rotation lock floating sub	
Telescoping mast	Licensed API 4F, 3rd edition	
Hydraulic "Carriage" feed system	180 ft/min	54 m/min
Single engine power	950 hp	708 kW
Custom carrier with hydraulic drive	500 hp	373 kW
Substructure with BOP House	Licensed API 4F, 3rd edition	
Rated Capacity	110 ton / 220,000 lb	100 tonnes / 100,000 kg
Large, Uncluttered Work Floor	220 ft <sup>2</sup>	20.4 m <sup>2</sup>
Removable Table (clear opening)	44"	1,118 mm
Bare Table Opening	27 ½"	699 mm
API Master Bushing (slip assembly)	17 ½"	445 mm
Hands-Free Breakout System Hydraulic roughneck	2 7/8" - 8 ¼" 65,000 lb-ft make-up 80,000 lb-ft breakout	73 mm - 338 mm 89.2 kNm make-up 108.5 kNm breakout
Operator's Control Station	On work floor or in drill cabin: optional Class 1, Division 2 rating	
Hands-Free Pipe Handling System	Hydraulic pipe skate	
Pipe & Casing Handling Capacity	Range II and III	
Pipe Storage and Handling	Twin fold-out pipe racks	

Visit [www.atlascopco.com/predator](http://www.atlascopco.com/predator) for more information



# Klaw Bits

## Design Features:

- Klaw cutters are placed at specific locations and attack angles for maximum formation removal
- 3D designed cutter locations and bit features are CNC machined to meet exact design specifications and ensure product repeatability
- Open center design for maximum air or fluid flow to all cutters on bit
- One-piece 4140 alloy steel bit body ensures maximum blade and body strength
- Strategically placed Tungsten Carbide inserts protect bit body
- Receptacle in shank allows use of air flow reduction washer when needed in 4 1/2" and 6 5/8" Reg API pin connections



### Technical specifications

K	4	1	L	F	C	X
K = Klaw Series	Blade Count	Pick Attack Angle 1 = H1, 2 = H2, 3 = H3	Port Size, S = Small, M = Medium, L = Large	Fishneck	Cased Hole (gages to API specs.)	Light Set (fewer picks - faster)

Typical Bit Sizes	API Pin Connection	Pick Count	Blade Count
5 5/8"	2 7/8" Reg	6	3
6", 6 1/4", 6 1/2", 6 3/4"	3 1/2" Reg	7, 8	3
7 7/8", 8 3/4", 9", 9 7/8", 10 5/8"	4 1/2" Reg	9-14	3, 4
9 7/8", 10 5/8", 11", 11 1/4", 11 3/4", 12 1/4", 13 1/2"	6" Reg	12-20	3, 4
17 1/2" to 36"	7" Reg	38 and up	7 and up



# Matrix Body PDC Bits

## Design Features:

- Cast infiltrated Tungsten Carbide matrix shell for maximum erosion and abrasion resistance
- 3D designed and CNC machined internal steel blank for maximum blade and body strength
- Thermally Stable Polycrystalline (TSP) diamond enhanced gage pads for maximum gage protection
- Parabolic profile is optimized for blade count, cutter quantity and bit stability
- Force-balanced PDC cutter locations minimize bit whirl and drill a precise round hole
- Asymmetrical blade design reduces drilling harmonics
- Blade protection elements are located strategically to maximize bit life. Standard bits have back-up tungsten carbide bumpers while "X" bits have back-up PDC cutters



### Technical specifications

Typical Bit Sizes	API Pin Connection	Standard PDC Cutter Size	Optional PDC Cutter Size	Standard Blade Count	Optional Blade Count
5 7/8", 6", 6 1/8", 6 1/4", 6 1/2", 6 3/4"	3 1/2" Reg	16 mm	13 mm, 19 mm	5, 6	4, 7, 8
7 7/8", 8 1/2", 8 3/4"	4 1/2" Reg	16 mm	13 mm, 19 mm	4, 5, 6	7, 8
9 7/8", 10 5/8", 11", 12 1/4"	6 5/8" Reg	16 mm	13 mm, 19 mm	5, 6	4, 7, 8
13 1/2", 13 3/4", 14 3/4"	6 5/8" Reg	19 mm	16 mm	6, 7	5, 8
15 1/2", 16", 17 1/2"	7 5/8" Reg	19 mm	16 mm	7, 8	6, 9

# Dirt Digger Premium PDC Bits

## Design Features:

- Cost effective PDC drill bit ideally suited for mining, construction, fiber optic, water well, geothermal and shallow oil & gas drilling
- PDC bit advantages over a traditional roller cone bit include longer bit life, smoother drilling operations and increased penetration rates
- 3D designed one-piece 4140 alloy steel body is CNC machined to exact design specifications for maximum blade and body strength
- Tapered parabolic profile design offers an optimal combination of cutter protection and ROP capabilities for a variety of formations and drilling conditions
- Optimized cutter distribution profile for blade count, cutter quantity, drilling conditions and bit stability
- Force-balanced PDC cutter locations minimize bit whirl and drill a precise round hole
- Asymmetrical blade layout reduces drilling harmonics
- Dirt Digger Premium (DP) bits have Tungsten Carbide Hardface applied to critical areas of the bit for erosion resistance

## Technical specifications

### DP316

Available sizes	Port count and size	TFA
6½"	6 @ 16/32"	1.18 in <sup>2</sup>
6¾"	6 @ 15/32"	1.18 in <sup>2</sup>
7⅞"	6 @ 17/32"	1.33 in <sup>2</sup>
8½"	6 @ 19/32"	1.66 in <sup>2</sup>
8¾"	6 @ 19/32"	1.66 in <sup>2</sup>

### DP516

Available sizes	Port count and size	TFA
7⅞"	5 @ LOP Nozzle	0.38 in <sup>2</sup> to 1.53 in <sup>2</sup>
8½"	5 @ LOP Nozzle	0.38 in <sup>2</sup> to 1.53 in <sup>2</sup>
8¾"	5 @ LOP Nozzle	0.38 in <sup>2</sup> to 1.53 in <sup>2</sup>

### DP616

Available sizes	Port count and size	TFA
8⅞"	8 @ LOP Nozzle	0.61 in <sup>2</sup> to 2.45 in <sup>2</sup>
12¼"	8 @ LOP Nozzle	0.61 in <sup>2</sup> to 2.45 in <sup>2</sup>





# Dirt Digger PDC Bits

## Design Features:

- Cost effective PDC drill bit ideally suited for mining, construction, fiber optic, water well, geothermal and shallow oil & gas drilling
- PDC bit advantages over a traditional roller cone bit include longer bit life, smoother drilling operations and increased penetration rates
- 3D designed one-piece 4140 alloy steel body is CNC machined to exact design specifications for maximum blade and body strength
- Optimized cutter distribution profile for blade count, cutter quantity, drilling conditions and bit stability
- Force-balanced PDC cutter locations minimize bit whirl and drill a precise round hole
- Asymmetrical blade layout reduces drilling harmonics

Technical specifications				
<b>D013</b>				
Available sizes				Series Specific Design Features
3"	3¾"	3⅞"	4¼"	Flat parabolic profile design offers maximum protection when drilling non-homogeneous and unconsolidated formations
4½"	4⅝"	4¾"	4⅞"	
5⅞"	5¼"	5⅝"	5½"	
5⅞"				
<b>D313</b>				
Available sizes				Series Specific Design Features
3⅞"	4¼"	4½"	4⅝"	Tapered parabolic profile design offers maximum ROP when drilling homogeneous and consolidated formations
4¾"	4⅞"	5⅞"	5¼"	
5⅞"	5½"	5⅝"	5⅞"	
<b>D513</b>				
Available sizes				Series Specific Design Features
5⅞"	5⅞"	6"	6⅞"	Tapered parabolic profile design offers an optimal combination of cutter protection and ROP capabilities for a variety of formations and drilling conditions
6¼"	6½"	6¾"	7⅞"	
8½"	8¾"	9⅞"	10⅝"	
11"	12¼"			



# PlugMaster PDC Bits (For drilling hydraulic fracturing plugs)

## Applications:

- PlugMaster PDC drill bits are specifically designed for drilling hydraulic fracturing plugs in lateral, vertical and directional wellbores
- Unique spiral blade configuration reduces torque fluctuations and promotes dynamic stability by distributing the cutting forces around the entire bit
- Deep junk slots allow efficient removal of all sizes of cuttings for all plug materials
- One piece steel body construction ensures bit integrity throughout the entire run
- Tungsten Carbide (TC) inserts in the gauge pads provide maximum gauge protection
- Each blade has its own dedicated fluid port for optimum flushing and removal of the cuttings

## Design Features:

- 3D designed one-piece 4140 alloy steel body is CNC machined to exact design specifications for maximum blade and body strength
- Cutter locations are optimized for blade count, cutter quantity, hydraulic frac plug drilling conditions and bit stability
- Fluid ports are sized and positioned to maximize hydraulic removal of the cuttings
- Spiral blade configuration allows smooth drilling through the various materials found in frac plugs



## Technical specifications

Size	Style	Part number	Number of blades	Number of 13 mm PDCs	Port size	TFA	Pin connection
3 3/8"	S413P	88053617	4	20	4 @ 1 5/32"	0.79 sq in	2 3/8" API Reg
3 3/4"	S413P	88053613	4	21	4 @ 1 5/32"	0.79 sq in	2 3/8" API Reg
3 7/8"	S413P	88053614	4	21	4 @ 1 5/32"	0.79 sq in	2 3/8" API Reg
3 7/8"	S413P	88053618	4	21	4 @ 1 5/32"	0.79 sq in	2 3/8" API Reg
4"	S413P	88053646	4	22	4 @ 1 5/32"	0.79 sq in	2 3/8" API Reg
4 1/2"	S613P	88053538	6	38	6 @ 1 5/32"	1.04 sq in	2 7/8" API Reg
4 5/8"	S613P	88053468	6	38	6 @ 1 5/32"	1.04 sq in	2 7/8" API Reg
4 3/4"	S613P	88053467	6	38	6 @ 1 5/32"	1.04 sq in	2 7/8" API Reg



# Steel Body PDC Bits

**Design Features:**

- 3D designed 4140 alloy steel body CNC machined for maximum blade and body strength
- Tungsten Carbide hardfacing in critical areas for increased erosion and abrasion resistance
- Tungsten Carbide Insert (TCI) enhanced gage pads for increased gage protection
- Parabolic profile is optimized for blade count, cutter quantity and bit stability
- Force-balanced PDC cutter locations minimize bit whirl and drill a precise round hole
- Asymmetrical blade design reduces drilling harmonics
- Blade protection elements are located strategically to maximize bit life. Standard bits have back-up TCI bumpers while "X" bits have back-up PDC cutters



Technical specifications					
Typical Bit Sizes	API Pin Connection	Standard PDC Cutter Size	Optional PDC Cutter Size	Standard Blade Count	Optional Blade Count
7 7/8", 8 1/2", 8 3/4"	4 1/2" Reg	16 mm	13 mm, 19 mm	5, 6	4, 7, 8
9 7/8", 10 5/8", 11", 12 1/4"	6 5/8" Reg	16 mm	13 mm, 19 mm	5, 6	4, 7, 8
13 1/2", 13 3/4", 14 3/4"	6 5/8" Reg	19 mm	16 mm	6, 7	5, 8
15 1/2", 16", 17 1/2"	7 5/8" Reg	19 mm	16 mm	7, 8	6, 9
20" to 36"	8 5/8" Reg	19 mm	16 mm	9, 11, 13	15

# Hydrocyclone and Jet Sub

## Dry hole – Better performance

Fluids sometimes need to be injected to clean a drilled hole, and until Hydrocyclone technology, drilling speeds were compromised as fluids were injected. Atlas Copco Secoroc's exclusive, patented system expels injected fluids just above the down-hole drill. The result? As much fluid as necessary can be injected without concern for loss of performance.

The hole stays clean, and the hammer runs as if it were operating dry. Over-the-hammer Jet Subs allow large volumes of air to be bypassed above the hammer. This feature reduces operating pressure and allows more hole cleaning for deep, wet or soft rock applications.

## Hydrocyclone features and benefits

- Increases performance with liquid injection.
- Expels liquids above DTH.
- Excellent choice for oil & gas and waterwell applications.

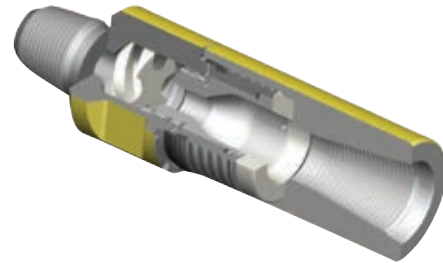

### Hydrocyclone kits

Size	Description	Thread	Outside diam. (English)		Length (shoulder to shoulder)		Wrench flat size	Max orifice size (six holes)	Weight	
			mm	inch	mm	inch			kg	lbs
3½"	Assembly with 1/8" orifice (6 gpm at 350 psig)	3½" API reg pin x box, pin up	142	5.60	371	14.6	4 AF x 2¼"	2 x ⅛"	2,800	6.300
4½"	Assembly with blank plate (14 gpm at 350 psig)	4½" API reg pin x box, pin up	181	7.13	181	22.5	5.9 AF x 2¼"	2 x ⅜"	4,000	8.800

## Jet Sub features and benefits

- Increases down-the-hole air capacity without need for booster
- Improves cuttings removal in deep holes
- Increased down-the-hole performance

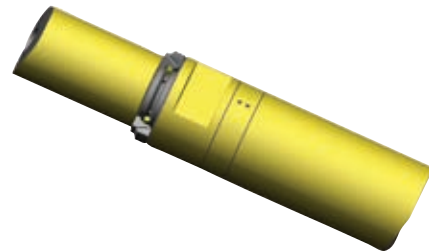

### Jet Sub crossover adapters

Thread configuration	Diameter	
	mm	inch
2⅝" API REG PIN X 3-1/2 API REG BOX	101.6	4.00
2⅝" API REG PIN X 2-7/8 API REG BOX	101.6	4.00
2⅞" API REG PIN X 3-1/2 API REG BOX	101.6	4.00
2⅞" API REG PIN X 2-7/8 API REG BOX	101.6	4.00
2⅝" API REG PIN X 2-3/8 API REG BOX	93.7	3.69
3½" API REG PIN X 3-1/2 API REG BOX	138.2	5.44
4½" API REG PIN X 4-1/2 API REG BOX	180.8	7.12
6⅝" API REG PIN X 6-5/8 API REG BOX	228.6	9.00

The above adapters can be added to any existing DTH hammer with the thread configuration as shown. They can also be added into the drill string between pipes as needed. There are also many models of Secoroc DTH hammers that are offered with the Jet Sub built into the backhead. Contact your Atlas Copco Secoroc customer center for information.



# Secoroc QLX 40 down-the-hole hammer

## QLX 40 – the latest in high performance 4" DTH hammers

The new Secoroc QLX 40 DTH hammer is the latest in the comprehensive line of QLX hammers. They represent the latest technology available on the market today by offering unbeatable capability, productivity and reliability in deep-hole drilling.

QLX hammers are optimized for deephole drilling applications in hard rock. At operating pressures up to 35 bar and a further improved QL™ air cycle the QLX 40 hammer can drill faster and deeper than any other hammer of its size.

The Secoroc QLX 40 is a 4" hammer that suits the water-well and geothermal market perfectly. The QLX 40 hammer is designed to operate in deephole conditions, with heavy water influx and severe back pressure. This means optimum

performance with regards to productivity and reliability in deephole conditions.

The QLX 40 12-spline bit shank maximizes the life of both the drive chuck and the bit splines. The shrink fit inner cylinder reduces the number of internal moving parts and increases the reliability. Add to that the new reliable check valve, and the QLX 40 is well protected from water and dirt entering the hammer.

The Secoroc QLX 40 can drill holes from 110 mm (4 15/16") to 130 mm (5 1/8") and is the ideal product for the drilling contractors looking for the best total economy of their drilling operations.

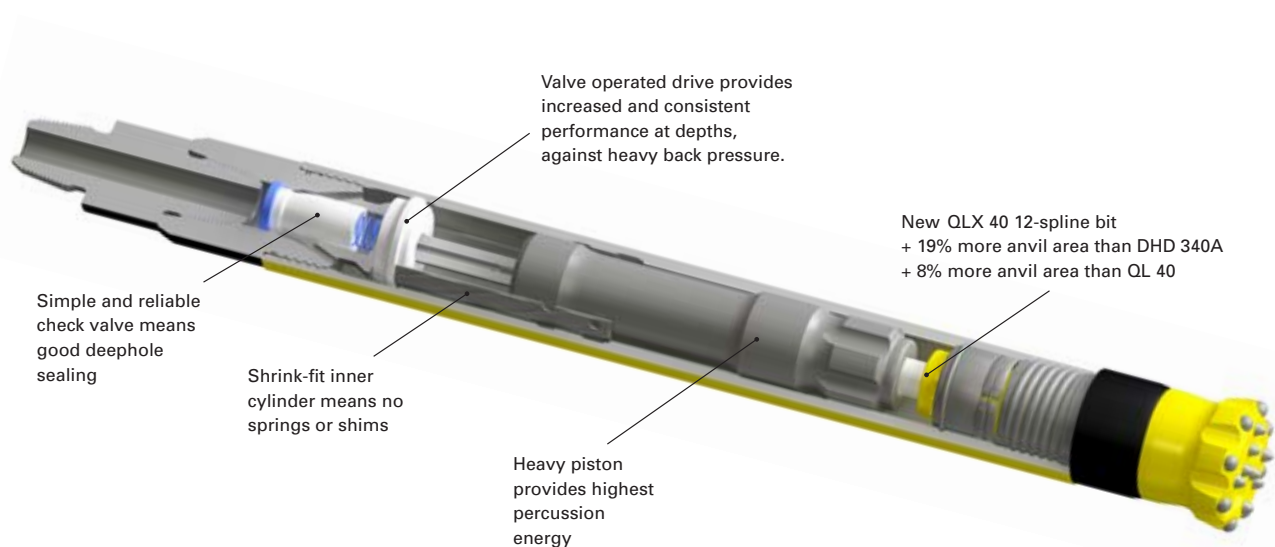

### General specifications

Backhead thread (excl. pin-pin sub)	2 3/8" API Reg box	
Bit shank	QLX 40	
Outside diameter	4"	101.6 mm
Length w/o bit shoulder to shoulder	35.3"	897.0 mm
Weight w/o bit	101.4 lb	46.0 kg
Backhead across flats	3"	76 mm
Recommended min. bit size	4.5"	115 mm
Recommended max. bit size	5.125"	130 mm
Bore	3.13"	79.5 mm
Piston weight	21.8 lb	9.9 kg
Stroke	4"	101.6 mm
Max pressure differential	508 psi	35.0 bar
Make-up torque	4,000 ft-lb	5,416 Nm

### Operational specifications

Feed force	2,000-3,000 lb	9-13 kN
Rotation speed	60-90 rpm	

### Air consumption and impact frequency

Air pressure	scfm	l/s	bpm**
100 psi / 6.9 bar	207	98	1,165
150 psi / 10.3 bar	297	140	1,320
200 psi / 13.8 bar	383	181	1,486
250 psi / 17.2 bar	480	227	1,618
300 psi / 20.7 bar	598	282	1,710
350 psi / 24.1 bar	727	343	1,835
400 psi / 27.6 bar*	831	392	2,057
450 psi / 31 bar*	947	447	2,254
500 psi / 34.5 bar*	1,063	501	2,449

\* Estimated value \*\* Blows per minute

### Secoroc QLX 40

Product No.	Product code	Thread
89010117	9704-QX-00-10P-64-000	2 3/8" API Reg Pin (incl. pin-pin sub)

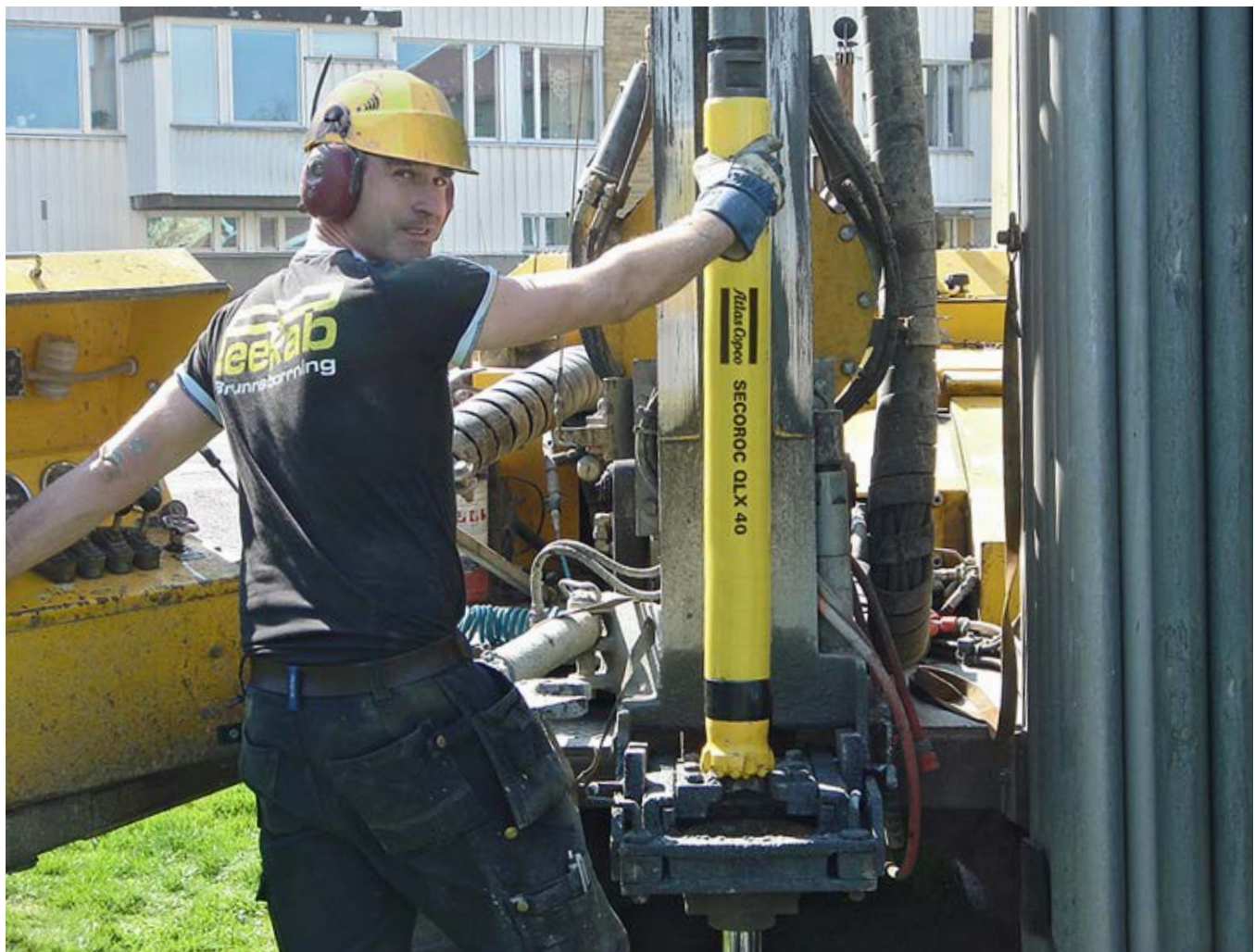

Bits mm (inch)	Product No.	Product code	No. of buttons x button diameter, mm (inch), shape	
			Gauge buttons	Front buttons
110 mm (4 3/16"), Flat front	90516005	100-5110-64-1210,10-20	8 x 14.5 mm (9/16"), Spherical	7 x 12.7 mm (1/2"), Spherical
115 mm (4 1/2"), Flat front	90516006	100-5115-64-1210,10-20	8 x 14.5 mm (9/16"), Spherical	8 x 12.7 mm (1/2"), Spherical
115 mm (4 1/2"), Flat front	90516450	100-5115-64-1228,10-20	8 x 15.8 mm (5/8"), Semi-ballistic	6 x 12.7 mm (1/2"), Semi-ballistic
120 mm (4 3/4"), Flat front	90516506	100-5120-64-1210,10-20	8 x 14.5 mm (9/16"), Spherical	8 x 12.7 mm (1/2"), Spherical
125 mm (4 9/16"), Flat front	90516227	100-5125-64-1210,10-20	8 x 14.5 mm (9/16"), Spherical	10 x 12.7 mm (1/2"), Spherical
130 mm (5 1/8"), Flat front	90516007	100-5130-64-1218,10-20	8 x 15.8 mm (5/8"), Spherical	8 x 14.5 mm (9/16"), Spherical
140 mm (5 1/2"), Flat front	90516447	100-5140-64-1218,10-20	8 x 15.8 mm (5/8"), Spherical	10 x 14.5 mm (9/16"), Spherical
152 mm (6"), Flat front	90516446	100-5152-64-1217,10-20	8 x 15.8 mm (5/8"), Spherical	8 x 15.8 mm (5/8"), Spherical
115 mm (1 1/2"), Speed bit	90516008	100-5115-64-1250,10-20	8 x 14.5 mm (9/16"), Spherical	8 x 12.7 mm (1/2"), Ballistic
120 mm (4 3/4"), Speed bit	90516516	100-5120-64-1250,10-20	8 x 14.5 mm (9/16"), Spherical	8 x 12.7 mm (1/2"), Ballistic
125 mm (4 9/16"), Speed bit	90516364	100-5125-64-1250,10-20	8 x 14.5 mm (9/16"), Spherical	10 x 12.7 mm (1/2"), Ballistic
130 mm (5 1/8"), Speed bit	90516365	100-5130-64-1250,10-20	8 x 14.5 mm (9/16"), Spherical	10 x 12.7 mm (1/2"), Ballistic
115 mm (4 1/2"), Concave	90003644	100-5115-64-0210,10-20	8 x 14.5 mm (9/16"), Spherical	6 x 12.7 mm (1/2"), Spherical
121 mm (4 3/4"), Concave	90516009	100-5121-64-0210,10-20	8 x 14.5 mm (9/16"), Spherical	8 x 12.7 mm (1/2"), Spherical
110 mm (4 3/16"), Rocket bit	90516010	100-5110-64-623A,10-20	8 x 12.7 mm (1/2"), Ballistic	8 x 12.7 mm (1/2"), Ballistic
115 mm (4 1/2"), Rocket bit	90516011	100-5115-64-623A,10-20	8 x 12.7 mm (1/2"), Ballistic	8 x 12.7 mm (1/2"), Ballistic
115 mm (4 1/2"), Rocket bit	90516012	100-5115-64-6210,10-20	8 x 14.5 mm (9/16"), Spherical	8 x 12.7 mm (1/2"), Spherical
Exhaust tube	90516004	9115		
Assembly tool	90516013	9141		



# Secoroc QLX 50/55 down-the-hole hammers

## QLX – the latest in high performance DTH hammers

QLX 50 and QLX 55 are primarily deephole hammers, but have also proven to be high performance hammers for other applications.

These new 5" hammers offer 20% more all-round performance than the QL hammers and better water-logged deep-hole drilling capacity than its predecessor, the TD 50 hammer. They are benchmarks with the highest rate of penetration (ROP), and reliability that are a cut above the rest, thanks to solutions such as the new e-kit making servicing easier and

quicker to execute. The QLX 55 has thicker heavy duty (HD) casing for longer service life when drilling in abrasive rock formations.

The QLX 50 and QLX 55 has been stringently field tested in USA and Sweden prior to launch. They have proven outstanding in water well, geothermal drilling and other applications, thanks to the air select feature that enables the QLX to match a variety of air packages while utilizing the excess air for hammer power.

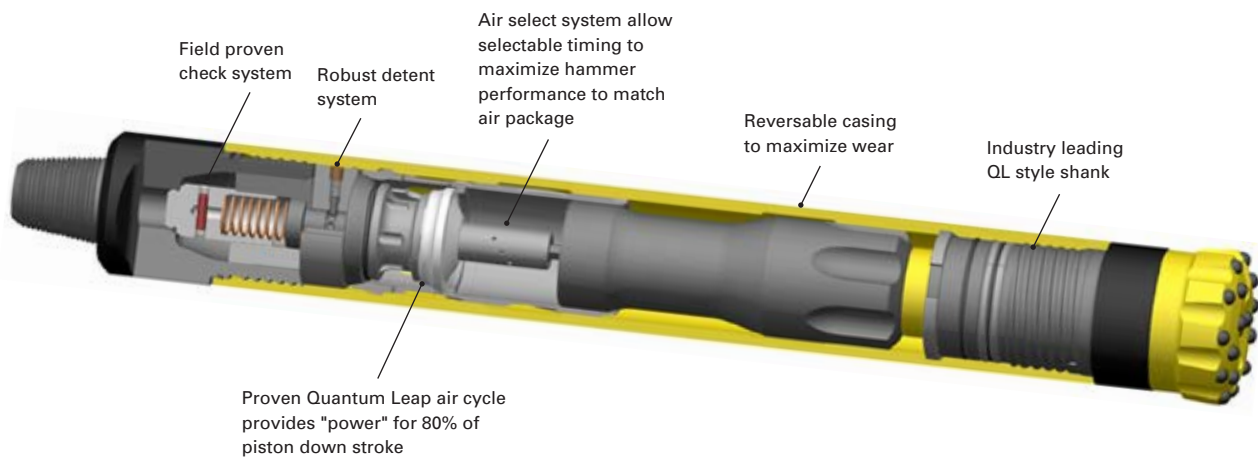

General specifications	QLX 50		QLX 55	
Connection Thread	3½" API Reg pin			
Bit shank	QL 50			
Outside diameter (in/mm)	4.8"	121.9	5.08"	129.0
Length w/o bit shoulder to shoulder (in/mm)	41.76"	1,060.7	41.76"	1,060.7
Weight w/o bit (lb/kg)	153.0	69.5	178.0	80.9
Backhead across flats (in/mm)	3.7"/4"	95/102	3.7"/4"	95/102
Recommended Min bit size (in/mm)	5.25"	134	5.5"	140
Recommended Max bit size (in/mm)	6"	152	6"	152
Bore (in/mm)	3.95"	100.3	3.95"	100.3
Piston weight (lb/kg)	33.0	15.0	33.0	15.0
Stroke (in/mm)	3.75"	95.3	3.75"	95.3
Max pressure differential (psig/bar)	500	34.5	500	34.5
Make-up torque (ft-lbf/Nm)	5,000	6,770	5,000	6,770

### Operational specifications

Feed force	1,500-2,000 lb	7-9 kN
Rotation speed	50-80 rpm	

Secoroc QLX 50/55			
Model	Product No.	Product code	Thread
QLX 50	89010092	9705-05-68-00	3½" API Reg pin
QLX 55	89010093	9705-05-68-14	3½" API Reg pin

### E-kit

Model	Product No.	Product code	Thread
QLX 50	89010124	9705-05-68-00-040	3½" API Reg pin
QLX 55	89010125	9705-05-68-14-040	3½" API Reg pin

### Air consumption and impact frequency (with Air select on default setting 2)

Air pressure	scfm	l/sec	bpm
100 psi / 6.9 bar	155	73	1,305
150 psi / 10.3 bar	257	121	1,426
200 psi / 13.8 bar	374	177	1,547
250 psi / 17.2 bar	508	240	1,668
300 psi / 20.7 bar	657	310	1,788
350 psi / 24.1 bar	822	388	1,909
400 psi / 27.6 bar*	961	453	2,029
450 psi / 31 bar*	1,109	524	2,114
500 psi / 34.5 bar*	1,258	594	2,270

\* Estimated value



Bits, mm (inch)	Product No.	Product code	No. of buttons x button diameter, mm (inch), shape	
			Gauge buttons	Front buttons
134 mm (5 1/4") Flat front	90514420	100-5134-25-1218,10-20	8 x 16 mm (5/8"), Spherical	8 x 14.5 mm (9/16"), Spherical
134 mm (5 1/4") Speed bit	90514674	100-5134-25-1248,10-20	8 x 16 mm (5/8"), Spherical	8 x 14.5 mm (9/16"), Semi-ballistic
134 mm (5 1/4") Concave	90514424	100-5134-25-0218,10-20	8 x 16 mm (5/8"), Spherical	7 x 14.5 mm (9/16"), Spherical
140 mm (5 1/2") Flat front	90514382	100-5140-25-1218,10-20	8 x 16 mm (5/8"), Spherical	8 x 14.5 mm (9/16"), Spherical
140 mm (5 1/2") Speed bit	90514386	100-5140-25-1248,10-20	8 x 16 mm (5/8"), Spherical	10 x 14.5 mm (9/16"), Semi-ballistic
140 mm (5 1/2") Concave	90514387	100-5140-25-0218,10-20	8 x 16 mm (5/8"), Spherical	8 x 14.5 mm (9/16"), Spherical
140 mm (5 1/2") Convex	90515424	100-5140-25-2339,10-20	9 x 14,5 mm (9/16"), Ballistic	10 x 14.5 mm (9/16"), Ballistic
140 mm (5 1/2") Convex	90515428	100-5140-25-2337,10-20	8 x 16 mm (5/8"), Ballistic	7 x 16 mm (5/8"), Ballistic
146 mm (5 3/4") Flat front	90515087	100-5146-25-1218,10-20	8 x 16 mm (5/8"), Spherical	8 x 16 mm (5/8"), Spherical
146 mm (5 3/4") Concave	90514484	100-5146-25-0217,10-20	8 x 16 mm (5/8"), Spherical	8 x 16 mm (5/8"), Spherical
146 mm (5 3/4") Convex	90514713	100-5146-25-2338,10-20	9 x 16 mm (5/8"), Ballistic	11 x 14.5 mm (9/16"), Ballistic
152 mm (6") Flat front	90514958	100-5152-25-1217,10-20	8 x 16 mm (5/8"), Spherical	8 x 16 mm (5/8"), Spherical
152 mm (6") Concave	90514974	100-5152-25-0217,10-20	8 x 16 mm (5/8"), Spherical	8 x 16 mm (5/8"), Spherical



# Secoroc QLX 60/65 down-the-hole hammers

## QLX – the latest in high performance DTH hammers

QLX 60 and QLX 65 are primarily deephole hammers, but have also proven to be high performance hammers in mining applications.

These new 6" hammers offer 20% more all-round performance than QL hammers and better water-logged deephole drilling capacity than its predecessor, the TD hammer. They are benchmarks with the highest rate of penetration (ROP), and reliability that are a cut above the rest, thanks to solutions such as the new e-kit making servicing easier and

quicker to execute. The QLX 65 has a thicker Heavy Duty (HD) casing for longer service life when drilling in abrasive rock formations.

The QLX 60 and QLX 65 have been stringently field tested, drilling almost 750,000 feet prior to the launch. They have proven outstanding in water well and mining applications, thanks to the air select feature that enables the QLX to match a variety of air packages while utilizing the excess air for hammer power.

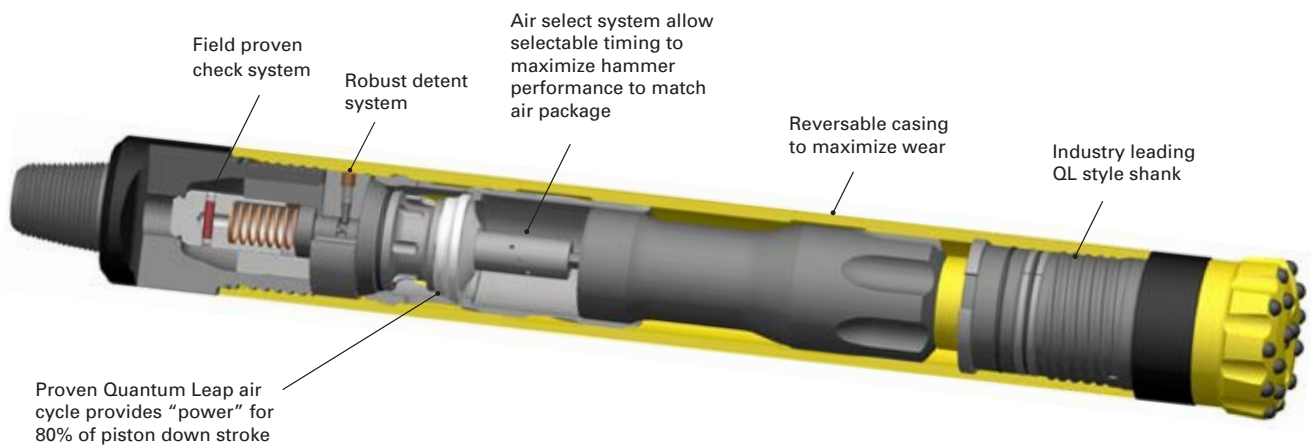

General specifications	QLX 60		QLX 65	
<b>Connection</b>	<b>3 1/2" API Reg pin</b>			
Bit shank	QL 60			
Outside diameter	5.60"	142.2 mm	5.88"	149.4 mm
Length w/o bit shoulder to shoulder	42.9"	1,090.7 mm	42.9"	1,090.7 mm
Length with bit ext.	48.1"	1,222.3 mm	48.1"	1,222.3 mm
Length with bit retracted	46.6"	1,184.4 mm	46.6"	1,184.4 mm
Weight w/o bit	205 lb	93.2 kg	235 lb	104.8 kg
Backhead across flats	2 1/4" x 4 AF	57.1 x 101.6 mm	2 1/4" x 4 AF	57.1 x 101.6 mm
Recommended min. bit size	6.125"	156 mm	6.50"	165 mm
Recommended max. bit size	8.00"	203 mm	8.00"	203 mm
Bore	4.750"	120.65 mm	4.750"	120.65 mm
Piston weight	47 lb	21.4 kg	47 lb	21.4 kg
Stroke	3.75"	95.3 mm	3.75"	95.3 mm
Max. pressure differential	500 psi	34 bar	500 psi	34 bar
Make-up torque	6,000 lbf-ft	8,135 Nm	6,000 lbf-ft	8,135 Nm

## Secoroc QLX 60/65

Model	Product No.	Product code	Thread
QLX 60	52352465	9706-05-68-00	3 1/2" API Reg pin
QLX 65	52352473	9706-05-68-14	3 1/2" API Reg pin



**Air consumption and impact frequency (with Air select on default setting 2)**

100 psi / 6.9 bar	229 scfm	6.5 m <sup>3</sup> /min	1,384 bpm
150 psi / 10.3 bar	360 scfm	10.2 m <sup>3</sup> /min	1,500 bpm
200 psi / 13.8 bar	502 scfm	14.2 m <sup>3</sup> /min	1,616 bpm
250 psi / 17.2 bar	655 scfm	18.5 m <sup>3</sup> /min	1,732 bpm
300 psi / 20.7 bar	818 scfm	23.1 m <sup>3</sup> /min	1,847 bpm
350 psi / 24.1 bar	994 scfm	28.1 m <sup>3</sup> /min	1,963 bpm
400 psi / 27.6 bar	1,160* scfm	32.9* m <sup>3</sup> /min	2,078* bpm
450 psi / 31.0 bar	1,330* scfm	37.7* m <sup>3</sup> /min	2,194* bpm
500 psi / 34.5 bar	1,499* scfm	42.5* m <sup>3</sup> /min	2,309* bpm

\* Estimated value

**Operational specifications**

Feed force	2,000-3,000 lbs	8.9-13.3 kN
Rotation speed	30-60 rpm	

Bits mm (inch)	Product No.	Product code	No. of buttons x button diameter, mm (inch), shape	
			Gauge buttons	Front buttons
156 mm (6 1/8") Dual Gauge	90515716	100-5156-26-4211,08-12	10 x 16 mm (5/8"), Spherical	10 x 16 mm (5/8"), Spherical
156 mm (6 1/8") Concave	90515684	100-5156-26-0217,08-20	8 x 16 mm (5/8"), Spherical	8 x 16 mm (5/8"), Spherical
159 mm (6 3/4") Flat front	90515688	100-5159-26-1217,08-20	8 x 16 mm (5/8"), Spherical	9 x 16 mm (5/8"), Spherical
159 mm (6 3/4") Dual Gauge	90515717	100-5159-26-4211,08-12	10 x 16 mm (5/8"), Spherical	10 x 16 mm (5/8"), Spherical
165 mm (6 1/2") Flat front	90515589	100-5165-26-1211,08-20	10 x 16 mm (5/8"), Spherical	10 x 16 mm (5/8"), Spherical
165 mm (6 1/2") Flat front	90515706	100-5165-26-1312,08-20	9 x 19 mm (3/4"), Spherical	9 x 16 mm (5/8"), Spherical
165 mm (6 1/2") Speed bit	90515609	100-5165-26-1241,08-20	10 x 16 mm (5/8"), Spherical	10 x 16 mm (5/8"), Semi-Ballistic
165 mm (6 1/2") Concave	90515617	100-5165-26-0217,08-12	8 x 16 mm (5/8"), Spherical	8 x 16 mm (5/8"), Spherical
165 mm (6 1/2") Convex	90515652	100-5165-26-221B,08-20	10 x 19 mm (3/4"), Ballistic	8 x 19 mm (3/4"), Ballistic
171 mm (6 3/4") Flat front	90515595	100- 5171-26-1211,08-20	10 x 16 mm (5/8"), Spherical	9 x 16 mm (5/8"), Spherical
171 mm (6 3/4") Concave	90515662	100-5171-26-0212,08-20	10 x 19 mm (3/4"), Spherical	12 x 16 mm (5/8"), Spherical
171 mm (6 3/4") Convex	90515634	100-5171-26-231B,08-20	9 x 19 mm (3/4"), Ballistic	10 x 19 mm (3/4"), Ballistic
171 mm (6 3/4") Convex	90516461	100-5171-26-231B,08-12	9 x 19 mm (3/4"), Ballistic	10 x 19 mm (3/4"), Ballistic
203 mm (8") Flat front	90514314	100-5203-26-1211,08-20	10 x 16 mm (5/8"), Spherical	16 x 16 mm (5/8"), Spherical



# Secoroc QLX 60 OG down-the-hole hammer

## QLX – the latest in high performance Oil and Gas DTH hammers

After taking the best from the TD hammer, added the best of the QL design, thrown in a few new ideas, Atlas Copco has created the QLX 60 OG DTH hammer.

This new 6" hammer offers 20% more all-round performance than QL hammers and better water-logged deephole drilling capacity than its predecessor, the TD hammer. The QLX 60 OG (with the new bit retrieval system) is a benchmark with the highest rate of penetration (ROP) and reliability, that is a cut above the rest thanks to solutions such as the new e-kit making servicing easier and quicker to execute.

The QLX 60 OG has been stringently field tested, drilling almost 750,000 feet prior to the launch. It has proven outstanding in oil and gas thanks to the design of the hammer to consume a large amount of air that is used in oil and gas drilling. Operators can push more air through the hammer by using the option with the vented bit bearing.

The QLX 60 OG is the first of a completely new range of reliable, high performers with the latest technology.

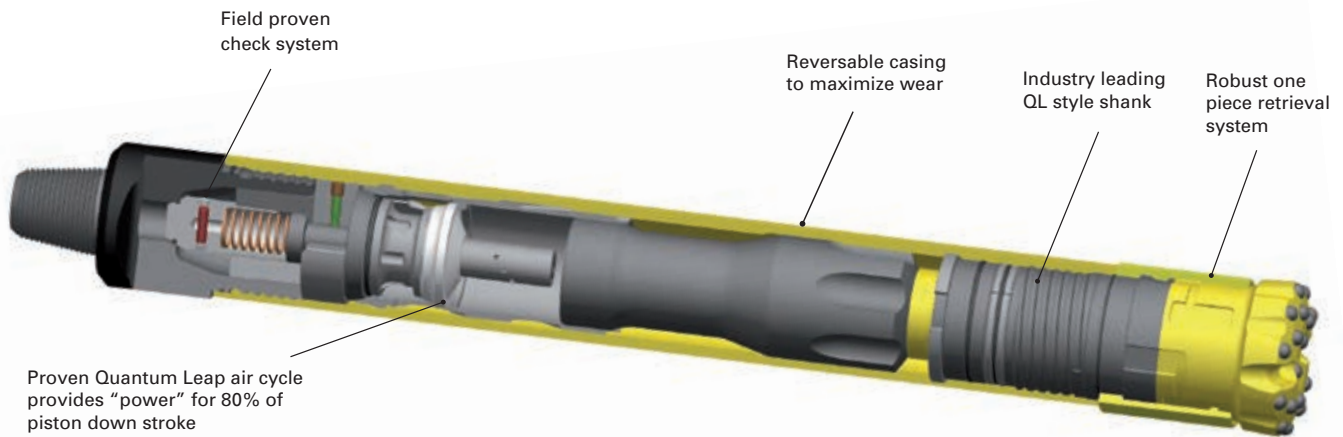

General specifications	Secoroc QLX 60 OG	
<b>Connection</b>	<b>3 1/2" API Reg Pin</b>	
Bit shank	QL 60	
Outside diameter	5.60"	142.2 mm
Length w/o bit shoulder to shoulder	42.9"	1,090.7 mm
Length with bit extended	48.1"	1,222.3 mm
Length with bit retracted	46.6"	1,184.4 mm
Weight w/o bit	205 lb	93.2 kg
Backhead across flats	2 1/4" x 4 AF	57.1 x 101.6 mm
Recommended min. bit size	6.125"	156 mm
Recommended max. bit size	6.50"	165 mm
Bore	4.750"	120.65 mm
Piston weight	47 lb	21.4 kg
Stroke	3.75"	95.3 mm
Maximum pressure differential	500 psig	34 bar
Make-up torque	6,000 ft-lb	8,135 N-m

Operational specifications		
Feed force	2,000 - 3,000 lb	8.9 - 13.3 kN
Rotation speed	30 - 60 rpm	

Secoroc QLX 60 OG		
Product No.	Product code	Thread
52354180	9706-QX-OG-14P-64-00R	3 1/2 API Pin, retrieval chuck, standard bearing
89010218	9706-QX-OG-14P-64-000	3 1/2 API Pin, standard chuck, standard bearing
89010219	9706-QX-OG-14P-64-00V	3 1/2 API Pin, standard chuck, vented bearing
89010220	9706-QX-OG-14P-64-00X	3 1/2 API Pin, retrieval chuck, vented bearing

Air consumption and impact frequency						
Pressure	with standard bearing			with vented bearing		
	scfm	m <sup>3</sup> /min	bpm	scfm	m <sup>3</sup> /min	bpm
250 psi / 17.2 bar	822	23.3	1,738	937	26.5	1,440
300 psi / 20.7 bar	1,018	28.8	1,855	1,228	34.7	1,704
350 psi / 24.1 bar	1,224	34.7	1,971	1,475	41.7	1,878
400 psi / 27.6 bar	1,440	40.8	2,086	1,680	47.5	1,956
450 psi / 31.0 bar	1,666	47.2	2,200	1,840	52.0	2,067
500 psi / 34.5 bar	1,901	53.8	2,312	1,958	55.0	2,162

# Secoroc QL80 down-the-hole hammer

## Strong performance and affordability

Our Quantum Leap product line is available for those seeking a good balance between strong performance and cost. This product line was the drilling industry's first hybrid combination

of valve and valveless-air cycle down-hole drills. Setting many industry benchmarks, the Quantum Leap® line continues to offer good value.

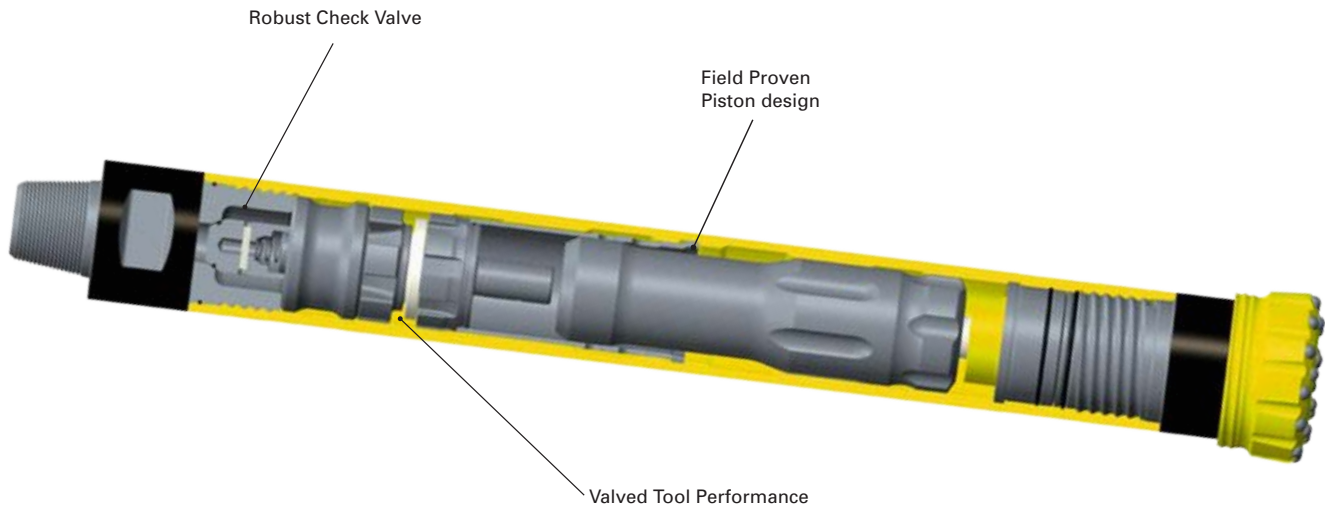

General specifications				
	Standard		Soft Rock/HF	
	English	Metric	English	Metric
<b>Standard drill pipe connection (see options)</b>	4½ API reg pin		4½ API reg pin	
Outside diameter (in, mm)	7.1	181	7.1	181
Length w/o bit shoulder to shoulder (in, mm)	57.5	1,461	57.5	1,461
Length with bit extended (in, mm)	63.5	1,612	63.5	1,612
Length with bit retracted (in, mm)	61.7	1,567	61.7	1,567
Weight w/o bit (lb, kg)	446	203	446	203
Backhead across flats (in)	2x5 ½ AF		2x5 ½ AF	
Minimum bit size (in, mm)	7.9	200	7.9	200
Maximum bit size (in, mm)	12.0	305	12.5	305
Bore (in, mm)	5.9	149	5.9	149
Piston weight (lb, kg)	112	51	117	53
Stroke (in, mm)	3.75	95	2.75	70
Maximum pressure differential (psig, bar)	350	25	350	25
Maximum choke diameter (in, mm)	0.50	12.7	0.50	12.7
Make-up torque (lbf-ft and Nm)	8,000	10,832	8,000	10,832
Shank style	QL80		QL80	

Air consumption				
	Standard		Soft Rock/HF	
	English	Metric	English	Metric
100 psi/6.9 bar (scfm, L/s)	391	184	331	156
Blows per minute	866		1,242	
150 psi/10.3 bar (scfm, L/s)	505	238	559	264
Blows per minute	966		1,282	
200 psi/13.8 bar (scfm, L/s)	680	321	784	370
Blows per minute	1,058		1,333	
250 psi/17.2 bar (scfm, L/s)	915	432	1,006	475
Blows per minute	1,141		1,396	
300 psi/20.7 bar (scfm, L/s)	1,211	571	1,225	578
Blows per minute	1,216		1,469	
350 psi/24.1 bar (scfm, L/s)	1,568	740	1,441	680
Blows per minute	1,283		1,283	

Above specifications/ratings are based on initial factory setting



# Secoroc TD85/90 down-the-hole hammer

## Maximum productivity

Our Total Depth product line is the best for drilling contractors, owner-operators and large corporations seeking maximum productivity from their costly drill-rig investment. This product line delivers industry-leading drilling performance using state-of-the-art technology. Our hybrid valved/valveless

design maximizes the productivity of your air compressor. An enlarged piston bore coupled with accurate matching of piston-to-bit weight deliver the industry's highest power output.

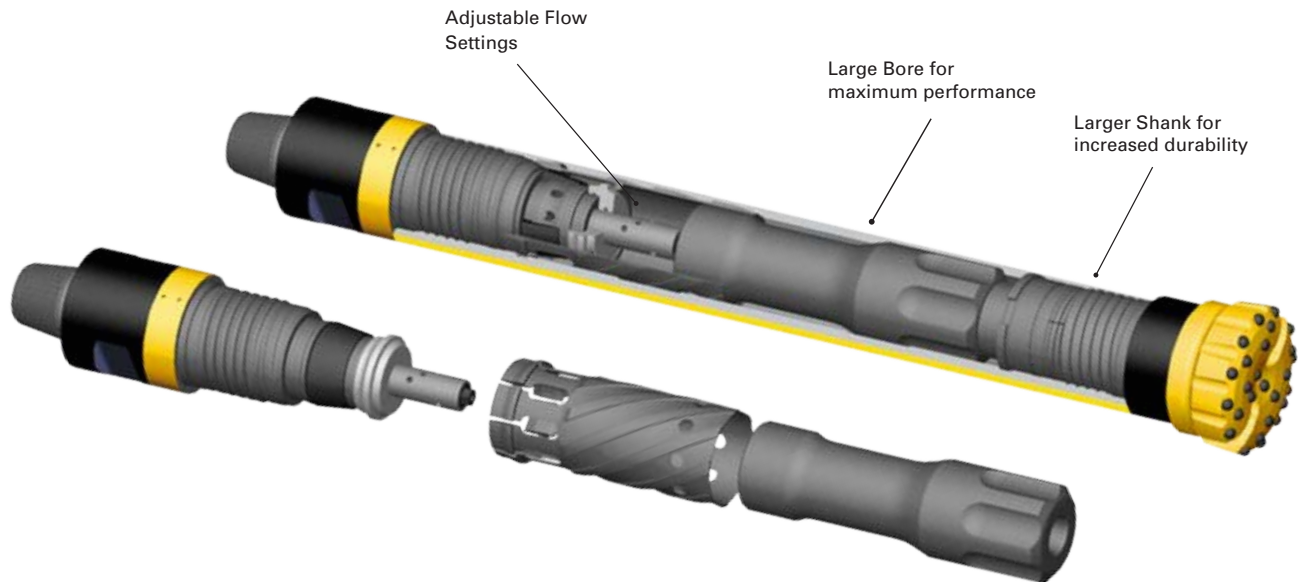

General specifications				
	TD85 Standard		TD90 Standard	
	English	Metric	English	Metric
<b>Standard drill pipe connection (see options)</b>	<b>4½ API reg pin</b>		<b>4½ API reg pin</b>	
Outside diameter (in, mm)	7.75	197	7.75	197
Length w/o bit shoulder to shoulder (in, mm)	55.5	1,410	55.5	1,461
Length with bit extended (in, mm)	63.8	1,619	63.8	1,619
Length with bit retracted (in, mm)	62.0	1,575	62.0	1,575
Weight w/o bit (lb, kg)	525	239	525	239
Backhead across flats (in)	6½x 2AF		6½x 2AF	
Minimum bit size (in, mm)	8.75	222	8.75	222
Maximum bit size (in, mm)	12.0	305	12.0	305
Bore (in, mm)	6.3	160	6.3	160
Piston weight (lb, kg)	119	54	119	54
Stroke (in, mm)	4.0	102	4.0	102
Maximum pressure differential (psig, bar)	350	25	350	25
Maximum choke diameter (in, mm)	0.50	12.7	0.50	12.7
Make-up torque (lbf-ft and Nm)	8,000	10,832	8,000	10,832
Shank style	QL80		TD90	

Air consumption		
	TD85/90	
100 psi/ 6.9 bar (scfm, L/s)	181	85
Blows per minute	902	
150 psi/ 10.3 bar (scfm, L/s)	468	221
Blows per minute	1,001	
200 psi/ 13.8 bar (scfm, L/s)	756	357
Blows per minute	1,099	
250 psi/ 17.2 bar (scfm, L/s)	1,044	492
Blows per minute	1,198	
300 psi/ 20.7 bar (scfm, L/s)	1,332	628
Blows per minute	1,297	
350 psi/ 24,1 bar (scfm, L/s)	1,619	764
Blows per minute	1,396	
Above specifications/ratings are based on initial factory setting		

# Secoroc QL120 down-the-hole hammer

## Strong performance and affordability

Our Quantum Leap product line is available for those seeking a good balance between strong performance and cost. This product line was the drilling industry's first hybrid combination

of valve and valveless-air cycle down-hole drills. Setting many industry benchmarks, the Quantum Leap line continues to offer good value.

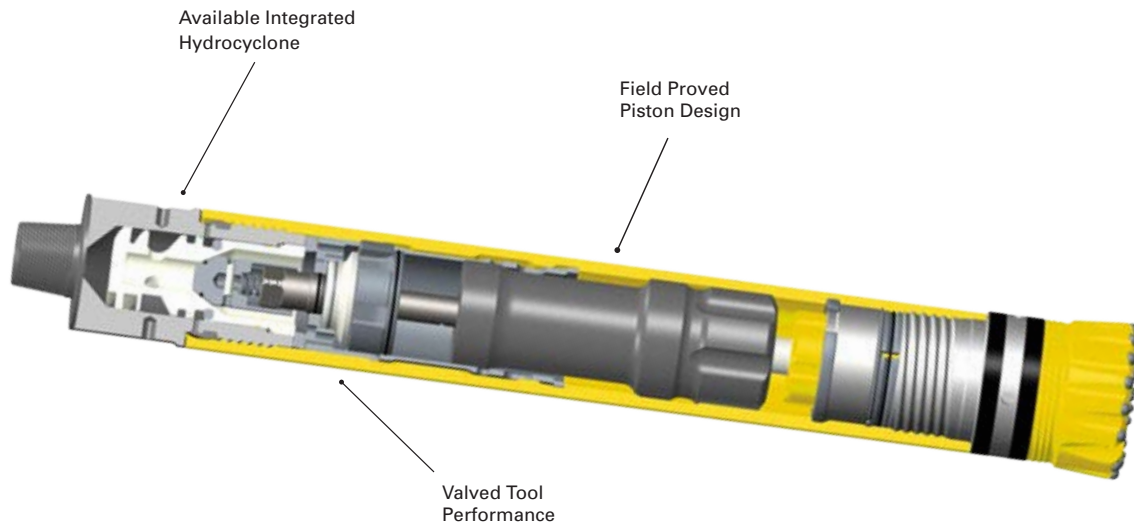

General specifications	Standard		Slim	
	English	Metric	English	Metric
<b>Standard drill pipe connection (see options)</b>	6% API reg pin		6% API reg pin	
Outside diameter (in, mm)	11.2	285	10.75	273
Length w/o bit shoulder to shoulder (in, mm)	72.3	1,837	72.3	1,837
Length with bit extended (in, mm)	82.0	2,083	82.0	2,083
Length with bit retracted (in, mm)	80.0	2,032	80.0	2,032
Weight w/o bit (lb, kg)	1,430	650	1,257	571
Backhead across flats (in)	4x1" AF		4x1" AF	
Minimum bit size (in, mm)	12.25	311	12.25	311
Maximum bit size (in, mm)	22.0	559	22.0	559
Bore (in, mm)	9.25	235	9.25	235
Piston weight (lb, kg)	350	159	350	159
Stroke (in, mm)	5.0	127	5.0	127
Maximum pressure differential (psig, bar)	250	17	250	17
Maximum choke diameter (in, mm)	0.75	19.0	0.75	19.0
Make-up torque (lbf-ft and Nm)	12,000	16,248	12,000	16,248
Shank style	QL120		QL120	

Air consumption		
	Standard	
100 psi/6.9 bar (scfm, L/s)	804	379
Blows per minute	585	
150 psi/10.3 bar (scfm, L/s)	1,248	589
Blows per minute	695	
200 psi/13.8 bar (scfm, L/s)	1,680	792
Blows per minute	805	
250 psi/17.2 bar (scfm, L/s)	2,100	990
Blows per minute	915	
300 psi/20.7 bar (scfm, L/s)	2,508	1,183
Blows per minute	1,025	
350 psi/24.1 bar (scfm, L/s)	2,904	1,370
Blows per minute	1,135	

Above specifications/ratings are based on initial factory setting



# Secoroc QLX 100 OG down-the-hole hammer

## Maximum performance

The QLX 100 OG 10" class hammer is equipped with the most reliable features from the industry leader in 12" hammers – the QL120 hammer. It delivers the maximum performance you have come to expect from the QLX line.

With the perfectly matched "shank to bit head ratio" and the hybrid QL valve cycle, the QLX 100 OG has proven to be a cut above the rest in both field trials and lab testing.

## Customer benefits

- Field proven "R4" retrieval system
- Available with new one piece design integrated Hydrocyclone
- High air consumption to maximum hole cleaning
- Highest ROP of any 10" hammer on the market

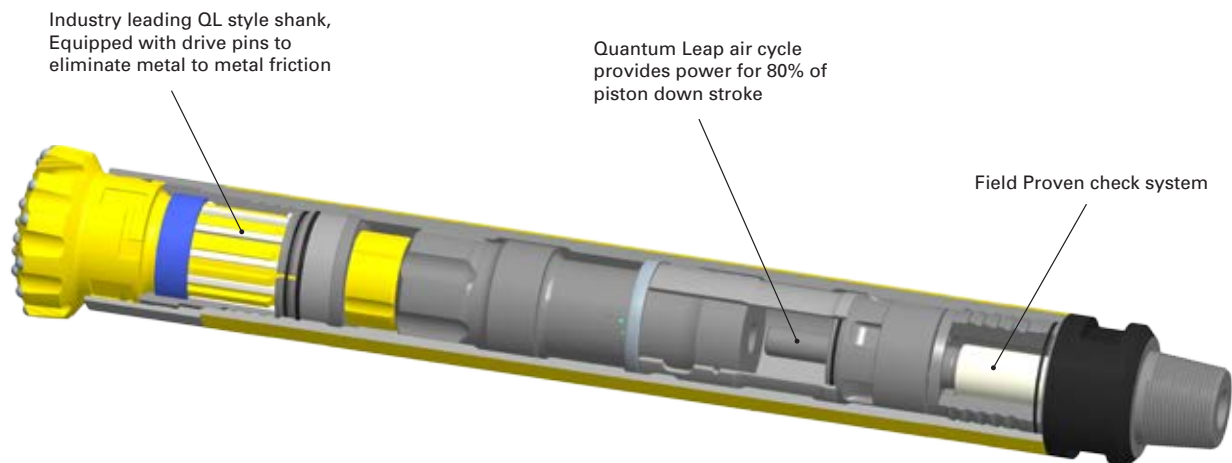

## QLX 100 OG specifications

General	English	Metric
Connection	6 $\frac{5}{8}$ Reg. pin	6 $\frac{5}{8}$ Reg. pin
Outside Diameter	9.00"	228.6 mm
Length, shoulder to shoulder, less bit	63.8"	4,620.5 mm
Length, bit extended	72.2"	1,833.9 mm
Length, bit retracted	70.4"	1,788.2 mm
Weight, less bit	1,007 lb	456.8 kg
Backhead flats	2.5" x 7" AF	63.5 mm x 178 mm AF
Minimum bit size	9.875"	251 mm
Maximum bit size	11"	279 mm
Bore	7.5"	190.5 mm
Piston weight	180 lb	81.6 kg
Stroke	4.75"	120 mm
Max pressure differential	500 psi	34.5 bar
Make up Torque	10,000 lbf-ft	1,130 Nm

## Operational specifications

General	English	Metric
Feed Force	4,000 - 5,000 lb	17.8 - 22.2 kN
Rotation Speed	20 - 40 rpm	20 - 40 rpm



Secoroc QLX 100 OG			
Model	Part No.	Product Code	Threaded Connection
QLX 100 OG - STD	89010474	9710-QX-OG-18P-40-00D	6 5/8" Reg Pin
QLX 100 OG - RET	89010479	9710-QX-OG-18P-40-00R	6 5/8" Reg Pin
QLX 100 OG - HC	89010534	9710-QX-OG-18P-40-0H0	6 5/8" Reg Pin
QLX 100 OG - HC - RET	89010535	9710-QX-OG-18P-40-0HR	6 5/8" Reg Pin

Air consumption		
Pressure	Flow (English)	Flow (metric)
100 psi, 6.9 bar	1,097 scfm	31.0 m <sup>3</sup> /min
100 psi, 6.9 bar (frequency)	827 bpm	827 bpm
150 psi, 10.3 bar	1,400 scfm	39.6 m <sup>3</sup> /min
150 psi, 10.3 bar (frequency)	910 bpm	910 bpm
200 psi, 13.8 bar	1,784 scfm	50.5 m <sup>3</sup> /min
200 psi, 13.8 bar (frequency)	993 bpm	993 bpm
250 psi, 17.2 bar	2,250 scfm	63.7 m <sup>3</sup> /min
250 psi, 17.2 bar (frequency)	1,075 bpm	1,075 bpm
300 psi, 20.7 bar	2,797 scfm	79.2 m <sup>3</sup> /min
300 psi, 20.7 bar (frequency)	1,158 bpm	1,158 bpm
350 psi, 24.1 bar	3,427 scfm	97.0 m <sup>3</sup> /min
350 psi, 24.1 bar (frequency)	1,240 bpm	1,240 bpm

Air consumption		
Product number	Description	Product code
59000180	9-5/8Q10R4XHG12XXXGPX	1RF-6244-40-431M,08-A1
59000181	9-7/8Q10R4XHG12XXXGPX	1RF-6251-40-431M,08-A1
59000182	10-5/8Q10R4XHG12XXXGPX	1RF-6270-40-431M,08-A1
59000176	10-7/8Q10R4XHG12XXXGPX	1RF-6276-40-431M,08-A1
59000183	11Q10R4XHG12XXXGPX	1RF-6279-40-431M,08-A1



# Booster B7-42/2175

## Standard features

- Automatic load / unload system
- On-board fuel tank
- Booster bypass manifold (single and 2-stage only)
- Engine speed adjustment
- Double acting concentric valves
- Watercooled booster block
- Precooler (a+15°F / 8°C) & suction scrubber tank
- Aftercooler (a+50°F / 28°C)
- Low pressure switch at booster inlet
- Open skid with fork lift pockets
- 24 volt DC starting and operating system
- Suction, interstage and discharge safety relief valves
- Full function instrument panel monitoring all pressures, temperatures and controls with full protection shutdown and fault indicators

## Options

- Digital control panel
- Automatic scrubber drain valve
- Cold weather kit (containerized units only)
- Manual louvers in front of coolers
- Airstarter
- Spark arrestor
- Overspeed shutdown valve
- Inlet particle filter
- Lights for night operation
- Service packs 250 / 500 hours
- Valve and piston kits

\* Containerized and rig safe models as well as other options, capacities and pressures are available upon request.



## Specifications

Booster type	Model 276 - 4 cylinders, reciprocating	
Drive Engine	Caterpillar C7 275 bhp @ 1800 rpm	
Booster stages	2	
Max suction pressure (psi / bar)	350 / 24	
Max discharge pressure (psi / bar)	2-stage: 2,175 / 150	1-stage: 800 / 55
Capacity at max suction pressure (cfm / m <sup>3</sup> /min)	2-stage: 1,288 / 37	1-stage: 1,600 / 45
Booster oil capacity (gal / l)	2.25 / 9	
Engine oil capacity (gal / l)	7.5 / 28	
Fuel tank capacity (gal / l)	85 / 321	
Max operating ambient temperature (°F / °C)	125 / 52	
Wet weight (lb / kg)	8,480 / 3,846	
Overall dimensions, L x W x H (in / cm)	150 x 85 x 89 / 381 x 216 x 226	
Suction connection	3" npt	
Discharge connection	1½" npt	

# Down-the-hole drill strings

## Atlas Copco waterwell drill rigs

For over 100 years Atlas Copco drills have had a major impact on the drilling community worldwide and have set the standard for quality, longevity, reliability and performance.

The T2W is a PTO (Power Take Off) truck mounted rig. While the T2W has evolved over the years to stay current with the markets requirements, it still maintains its rapid robust feed system and ability to carry water injection, mud system and air on-board the rig. The T2W comes complete with pipe box and carousel to carry up to 150m (500ft) with the drill rig.

Now the mainstay of the waterwell range, the T3W/TH60 still derive their roots from the original cyclone design with the carousel integrated into the tower. As with the T2W both units carry all options on-board and have the ability to carry nearly 180 m (600 ft) of drill pipe combined in the carousel and pipe box.

Developed in 1968 the T4W started a revolution in air drilling with its large deck engine to drive a 'big air' package. The T4W is still viewed as the workhorse in the range.



Specifications	T2W	
Rig data	metric	imperial
Derrick/feed length	6.4 m	21 ft
Pull back	13,600 kg	30,000 lb
Pull down	13,600 kg	30,000 lb
Hole range	110 - 203 mm	4 5/16 in - 8"
Hole depth*	360 m	1,200 ft
Spindle thread connection	API 4" IF BOX	
Spindle sub length (s/s) mm, in	1,778 mm	70"
Spindle sub threads opt. 1	API 4" IF PIN x API 2 3/8" IF PIN	
Spindle sub threads opt. 2	API 4" IF PIN x API 2 7/8" IF PIN	
Spindle sub threads opt. 3	-	

T3W	
metric	imperial
8.3 m	27 ft 4"
18,100 kg	40,000 lb
11,300 kg	25,000 lb
105 - 254 mm	4 1/8" - 10"
450 m	1,500 ft
API 3 1/2" IF PIN	
1,016 mm	40"
API 3 1/2" IF BOX x API 2 7/8" IF PIN	
API 3 1/2" IF BOX x API 3 1/2" Reg PIN	
API 3 1/2" IF BOX x API 3 1/2" IF PIN	

T3WDH	
metric	imperial
8.3 m	27 ft 4"
31,700 kg	70,000 lb
13,600 kg	30,000 lb
105 - 254 mm	4 1/8" - 10"
915 m	3,000 ft
API 3 1/2" IF PIN	
1,016 mm	40"
API 3 1/2" IF BOX x API 2 7/8" IF PIN	
API 3 1/2" IF BOX x API 3 1/2" Reg PIN	
API 3 1/2" IF BOX x API 3 1/2" IF PIN	

Air capacity	T2W	
Compressor opt. 1	189 L/s / 14 bar	500 cfm / 200 psi
Compressor opt. 2	330 L/s / 21 bar	750 cfm / 300 psi
Compressor opt. 3	423 L/s / 24.1 bar	900 cfm / 350 psi

T3W	
423 L/s / 24.1 bar	900 cfm / 350 psi
505 L/s / 24.1 bar	1,070 cfm / 350 psi
-	-

T3WDH	
423 L/s / 24.1 bar	900 cfm / 350 psi
505 L/s / 24.1 bar	1,070 cfm / 350 psi
-	-

Drill string	T2W	
DTH hammer size	4/5/6/8"	
Design group for pipes	TH60	
Pipe configuration	PIN down	
Pipe length	6.1 m	240"
Pipe OD	89 mm, 114 mm	3 1/2" in, 4 1/2"

T3W	
4/5/6/8"	
TH60	
PIN down	
6.1 m	240"
89 mm, 114 mm	3 1/2", 4 1/2"

T3WDH	
4/5/6/8"	
TH60	
PIN down	
6.1 m	240"
89 mm, 114 mm	3 1/2", 4 1/2"

Thread connection	T2W	
Pipe - Thread option A	API 2 3/8" IF	
Pipe - Thread option B	API 2 7/8" IF	
Pipe - Thread option C	-	

T3W	
API 2 3/8" IF	
API 2 7/8" IF	
API 3 1/2" Reg	

T3WDH	
API 2 3/8" IF	
API 2 7/8" IF	
API 3 1/2" Reg	





T4W	
metric	imperial
10.1 m	33 ft 3"
22,700 kg	50,000 lb
13,600 kg	30,000 lb
140 - 254 mm	5 1/2" - 10"
550 m	1,800 ft
API 4" IF BOX	
482 mm (Spur gear head)	19"
381 mm (Worm gear head**)	15"
API 4" IF PIN x API 2 7/8" IF BOX	
API 4" IF PIN x API 3 1/2" Reg BOX	
-	

T4WDH	
metric	imperial
10.1 m	33 ft 3"
31,800 kg	70,000 lb
13,600 kg	30,000 lb
140 - 254 mm	5 1/2" - 10"
915 m	3,000 ft
API 4" IF BOX	
482 mm (Spur gear head)	19"
381 mm (Worm gear head**)	15"
API 4" IF PIN x API 2 7/8" IF BOX	
API 4" IF PIN x API 3 1/2" Reg BOX	
-	

TH60	
metric	imperial
8.3 m	27 ft 4"
18,100 kg	40,000 lb
11,300 kg	25,000 lb
105 - 254 mm	4 1/8" - 10"
450 m	1,500 ft
API 3 1/2" IF PIN	
1,016 mm	40"
API 3 1/2" IF BOX x API 2 7/8" IF PIN	
API 3 1/2" IF BOX x API 3 1/2" Reg PIN	
API 3 1/2" IF BOX x API 3 1/2" IF PIN	

TH60DH	
metric	imperial
8.3 m	27 ft 4"
31,800 kg	70,000 lb
13,600 kg	30,000 lb
105 - 254 mm	4 1/8" - 10"
915 m	3,000 ft
API 3 1/2" IF PIN	
1,016 mm	40"
API 3 1/2" IF BOX x API 2 7/8" IF PIN	
API 3 1/2" IF BOX x API 3 1/2" Reg PIN	
API 3 1/2" IF BOX x API 3 1/2" IF PIN	

T4W	
505 L/s / 24.1 bar	1,070 cfm / 350 psi
590 L/s / 24.1 bar	1250 cfm / 350 psi
-	-

T4WDH	
505 L/s / 24.1 bar	1,070 cfm / 350 psi
590 L/s / 24.1 bar	1,250 cfm / 350 psi
-	-

TH60	
423 L/s / 24.1 bar	900 cfm / 350 psi
505 L/s / 24.1 bar	1070 cfm / 350 psi
-	-

TH60DH	
505 L/s / 24.1 bar	1,070 cfm / 350 psi
-	-
-	-

T4W	
5/6/8/12"	
T4	
PIN up	
7.6 m	300"
114 mm	4 1/2"

T4WDH	
5/6/8/12"	
T4	
PIN up	
7.6 m	300"
114 mm	4 1/2"

TH60	
4/5/6/8"	
TH60	
PIN down	
6.1 m	300"
89 mm, 114 mm	3 1/2", 4 1/2"

TH60DH	
4/5/6/8"	
TH60	
PIN down	
6.1 m	300"
89 mm, 114 mm	3 1/2", 4 1/2"

T4W	
API 2 7/8" IF	
API 3 1/2" Reg	
-	

T4WDH	
API 2 7/8" IF	
API 3 1/2" Reg	
-	

TH60	
API 2 7/8" IF	
API 2 7/8" IF	
API 3 1/2" Reg	

TH60DH	
API 2 7/8" IF	
API 2 7/8" IF	
API 3 1/2" Reg	

# Rotary drilling



TCI Bit



Tricone bit



Drag Bit



TDC Bit

## Tricone Drill Bits

Invented by Howard Hughes, the three cones interact with one another to reduce the formation into suitably sized pieces so that they can be flushed clear of the borehole.

Tricones fall into two main categories – Mill Tooth and Tungsten Carbide Insert (TCI).

Mill Tooth cones are literally cut from a cone of steel, with different tooth lengths and spacings, depending on the formations to be drilled. Predominantly used in sedimentary formations.

TCI bits have inserts placed into the steel cones (similar to DTH Bits), the size and shape of the inserts, dictating the kind of formations to be drilled. Often used for drilling harder igneous formations, especially with hemi-spherical inserts.

Both types of tricones require much greater bit loadings than is normally associated with DTH drilling; insufficient bit loading will produce low penetration rates and lead to premature bearing failure. This means that the BHA needs to match the bit type, formation and rig capabilities. Rotary drilling also requires significantly higher torque, which increases hole deviation, so again the BHA plays a significant role in how

## Drag bits

Dragbits are very simple, having no moving parts and are exceptionally good in soft (clays, mudstones) and unconsolidated (sands, gravels) formations. Requiring far less bit weight than tricones they are more suitable for smaller rigs, much less expensive and often overlooked. Well the hole drills.

## PDC bits

Polycrystalline Diamond Compact (PDC) bits are high tech versions of traditional drag bits, extensively used in oil and gas drilling with mud motors for steering directionally drilled wells.

Atlas Copco can supply a large range of rotary drilling bits and accessories, but again it needs to be stressed that careful selection is essential and that as much information needs to be gathered as is possible and then call in the services of one of Atlas Copco's bit specialists.

The information above is for guidance only and you should always contact an Atlas Copco Specialist before final selections are made.

# BHA—Bottom Hole Assembly

## Deephole drilling

We define a deephole as a hole being drilled to 300 m (1000 ft) or deeper. There are several applications where a deephole is required, such as shallow oil and gas, large sized water wells, dewatering projects and geothermal applications to name a few.

## How to successfully drill a deephole

The deeper the hole gets, the more you need to think and plan regarding how to drill your hole and how to design your drill string.

"Spaghetti drilling" is a term used to describe a situation where the drill string is not under tension and starts to act like wet spaghetti in the hole, causing excessive stress to the tool joints and increase wear to sections of the pipes.

The drill string should be designed with a BHA that provides sufficient weight on bit. A correctly designed BHA will keep

the drill pipes in tension at all times during drilling, which is one of the two criteria's needed to successfully drill a deep-hole.

The second criteria is to build the BHA with a three point stabilization, ensuring that the BHA is centralized in the hole at all times during drilling.

The BHA is an arrangement of drill collars and stabilizers located in the drill string directly after the DTH hammer or the tricone bit. The sole purpose of the BHA is to provide sufficient weight on bit, to guide the drill string and to minimize the stress on different components in the drill string. This setup ensures that the hole is being drilled with the least possible amount of stress and deviation.

Different applications and hole depths have different needs for how to design your BHA. Typically, water well drilling to depths down to 200 m (650 ft) would only require drill collars in the BHA.



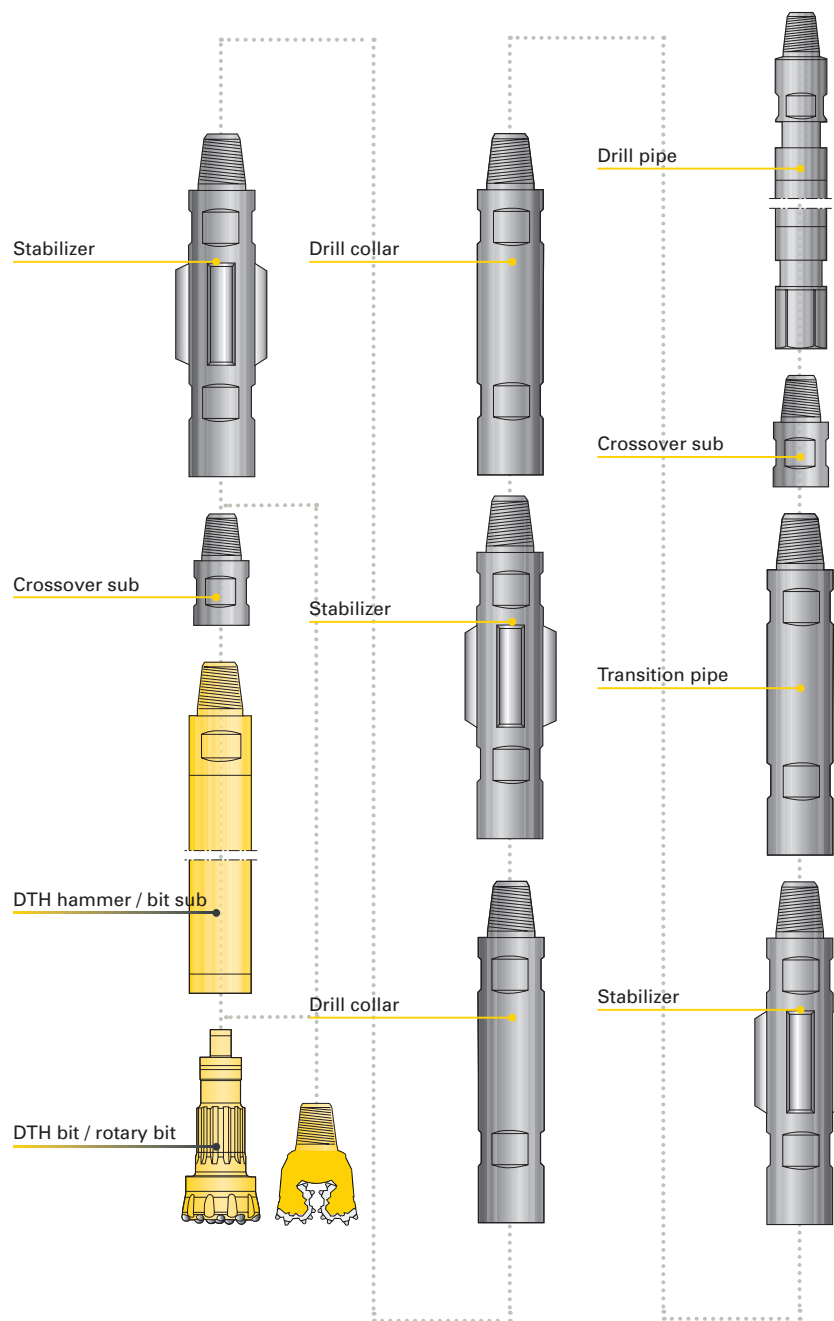

The size of drill collars and stabilizers varies with the size of the hole being drilled. Using a three point stabilizing design is recommended for deephole drilling, i.e. placing 3 stabilizers in the BHA – One located directly after the DTHhammer or the tricone bit, one in the middle of the BHA and the last one on top of the last drill collar (see the image on next page).

A properly designed BHA will keep the drill pipes kept in tension at all times during drilling, where the three point stabilization will ensure that the BHA is centered in the hole.

### Drill collars

The purpose of the drill collar is to provide weight on bit. A drill collar is typically made from solid bar where the thread is cut directly on the body. The number of drill collars to use in the BHA is determined by the hole size and the size of the hammer being used.

### Stabilizers

The purpose of the stabilizers is to centralize the drill string in the hole and thereby preventing hole deviation. A stabilizer is normally designed to be  $\frac{3}{8}$ " (~9 mm) smaller than the bit size. Stabilizers comes in a variety of designs, were both ribbed and spiraled stabilizers are commonly used.

### Transition pipe

A transition pipe is stiffer than a drill pipe, but more flexible than a drill collar. The transition pipe is normally placed between the BHA and the drill pipes, making the drill string more durable and less sensitive for breakage.

# Atlas Copco T2W drill rigs

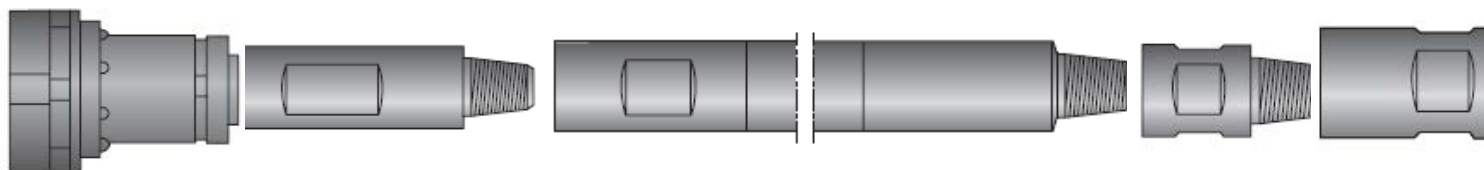

### T2W Rotation unit thread connection: API 4" IF BOX 89 mm (3 1/2") OD drill string, API 2 3/8" IF. For 110–152 mm (4 3/16"–6") holes

Spindle options	Saver sub	Drill pipe	Adapter	Drill collar*
<b>Fixed spindle</b> 89 mm (3 1/2") API 4" IF PIN x 2 3/8" IF PIN 1,778 mm (70") N/A 57679516 ADS Product	Not needed	89 mm (3 1/2") API 2 3/8" IF 6,09 m (20 ft) 104 kg (229 lb) 58160896 211-089-0609-B48-E0, 40-08	Not needed	Not needed
OR <b>Floating spindle</b> 89 mm (3 1/2") API 4" IF PIN x 2 3/8" IF BOX 673 mm (26 1/2") N/A 57881088 ADS Product	89 mm (3 1/2") API 2 3/8" IF PIN x 2 3/8" IF PIN 1,105 mm (43 1/2") N/A On request ADS Product	89 mm (3 1/2") 2 3/8" IF PIN x 2 3/8" IF PIN 1,105 mm (43 1/2") N/A	89 mm (3 1/2") API 2 3/8" IF BOX x 3 1/2" IF PIN 530 mm (20 7/8") 34 kg (75 lb) 58171422 311-2089-15-053-01-D48,41	127 mm (5") API 3 1/2" IF BOX x PIN 6.09 m (20 ft) 463 Kg (1021 lb) 58219254 215-8860-48,55-32

### 114 mm (4 1/2") OD drill string, API 2 7/8" IF. For 133 - 203 mm (5 1/4"–8") holes

Spindle adapter	Saver sub	Drill pipe	Adapter	Drill collar*
<b>Fixed spindle</b> 114 mm (4 1/2") API 4" IF PIN x 2 7/8" IF PIN 1,778 mm (70") N/A 57477630 ADS Product	Not needed	114 mm (4 1/2") API 2 7/8" IF BOX x PIN 6.09 m (20 ft) 158 kg (348 lb) 57690448 213-114-0610-B48-L0, 40-08	Not needed	Not needed
OR <b>Floating spindle</b> 89 mm (3 1/2") API 4" IF PIN x 2 7/8" IF BOX 673 mm (26 1/2") N/A 57881088 ADS Product	89 mm (3 1/2") API 2 7/8" IF PIN x 2 3/8" IF PIN 1,105 mm (43 1/2") N/A 57881096 ADS Product	114 mm (4 1/2") API 2 7/8" IF BOX x PIN 6.09 m (20 ft) 158 kg (348 lb) 57690448 213-114-0610-B48-L0, 40-08	114 mm (5") API 2 7/8" IF BOX x 3 1/2" IF PIN 530 mm (20 7/8") 37 Kg (82 lb) 58171448 313-2114-15-053-01-D48,41	127 mm (5") API 3 1/2" IF BOX x PIN 6.09 m (20 ft) 463 Kg (1021 lb) 58219254 215-8860-48,55-32

### Up-hole velocity per hole range and compressor size (89 mm OD pipes)

Hole Size	189 L/s / 14 bar (400 cfm / 200 psi)	330 L/s / 21 bar (700 cfm / 300 psi)	424 L/s / 24 bar (900 cfm / 350 psi)
110 - 130 mm (4 3/16 - 5 1/8")	58 - 27 m/s (11,338 - 5 277 fpm)	101 - 47 m/s (19,797 - 9 214 fpm)	129 - 60 m/s (25,436 - 11,838 fpm)
134 - 152 mm (5 1/4 - 6")	24 - 16 m/s (4,722 - 3 121 fpm)	42 - 28 m/s (8,244 - 5,449 fpm)	54 - 36 m/s (10,593 - 7,001 fpm)
152 - 203 mm (6 - 8")	16 - 7 m/s (3,121 - 1 423 fpm)	28 - 13 m/s (5,449 - 2,458 fpm)	36 - 16 m/s (7,001 - 3,193 fpm)





Adapter / Bit sub	DTH hammer	DTH bit size	WOB**
89 mm (3½") API 2¾" Reg BOX x API 2 ¾" IF BOX 508 mm (20") 17 kg (37 lb) 58135732 311-1089-10-051-01-D00,41	<b>QLX 40</b> 102 mm (4") API 2¾" Reg PIN 897 mm (35½") 46 kg (100 lb) 89010117 9704-QX-00-10P-64-000	110 - 130 mm 4 5/16 - 5 1/8"	1,200 kg
127 mm (4¾") API 3½" Reg BOX x 3½" IF BOX 508 mm (20") 18 kg (40 lb) 89010494 315-1127-14-051-01-K48,41	<b>QLX 60</b> 142 mm (5 19/32") API 3½" Reg PIN 1091 mm (42 15/16") 93 kg (205 lb) 52352465 9706-QX-00-14P-64-000	152 - 203 mm 6 - 8"	2,200 kg

**Legend****Description:**

OD, mm:  
Thread:  
Length, (s/s):  
Weight:  
Prod. No.:  
Prod. code:

\* Add quantity of drill collar to match the recommended weight on bit

\*\* Weight On Bit

**Up-hole velocity**

Up-hole velocity depends on available air volume, bit/hole size and pipe OD. The cutting speed should be at least 20 m/s in order to keep the hole clean. Too high of a speed will result in excessive wear on the drill string. Our recommended up-hole velocity is 30-50 m/s.

Adapter / Bit sub	DTH hammer	DTH bit size	WOB**
114 mm (4½") API 3½" Reg BOX x API 2¾" IF BOX 508 mm (20") 27 kg (60 lb) 58135849 313-1114-14-051-01-E48,41	<b>QLX 50</b> 122 mm (4 13/16") API 3½" Reg PIN 1,061 mm (41 3/4") 69 kg (153 lb) 89010092 9705-QX-00-14P-64-000	134 - 152 mm 5 ¼ - 6"	1,500 kg
127 mm (4¾") API 3½" Reg BOX x 3½" IF BOX 508 mm (20") 18 kg (lb) 89010494 315-1127-14-051-01-K48,41	<b>QLX 60</b> 142 mm (5 19/32") API 3½" Reg PIN 1,91 mm (42 15/16") 93 kg (205 L/s) 52352465 9706-QX-00-14P-64-000	152 - 203 mm 6 - 8"	2,200 kg

**Up-hole velocity per hole range and compressor size (114mm OD pipes)**

Hole Size	189 L/s / 14 bar (400 cfm / 200 psi)	330 L/s / 21 bar (700 cfm / 300 psi)	424 L/s / 24 bar (900 cfm / 350 psi)
110 - 130 mm (4 5/16 - 5 1/8")	N/A	N/A	N/A
134 - 152 mm (5 ¼ - 6")	49 - 24 m/s (9,553 - 4,688 fpm)	85 - 42 m/s (16,680 - 8,185 fpm)	109 - 53 m/s (21,431 - 10,516 fpm)
152 - 203 mm (6 - 8")	24 - 9 m/s (4,688 - 1,679 fpm)	42 - 15 m/s (8,185 - 2,932 fpm)	53 - 19 m/s (10,516 - 3,768 fpm)

# Atlas Copco TH60, T3W drill rigs

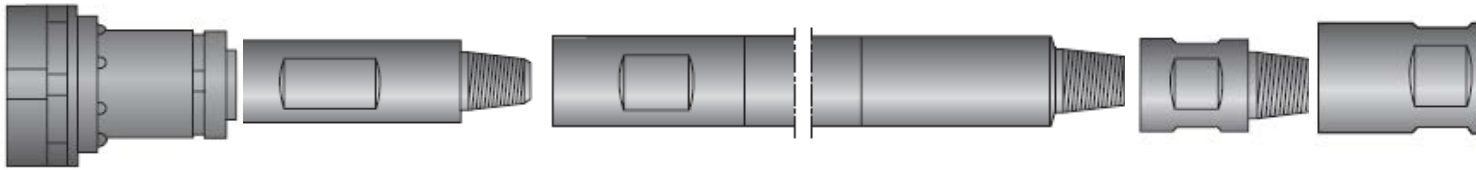

TH60, TH60 DH, T3W, T3W DH Rotation unit thread connection: API 3 1/2" IF PIN 89 mm (3 1/2") OD drill string, API 2 3/8" IF. For 110 - 152 mm (4-5/16" - 6.00") holes				
Spindle	Saver sub	Drill pipe	Adapter	Drill collar*
<b>Fixed spindle</b> 89 mm (3 1/2") API 3 1/2" IF BOX x 2 3/8" IF PIN 1,061 mm (40") N/A 57679516 ADS Product	Not needed	89 mm (3 1/2") API 2 3/8" IF 6.09 m (20 ft) 104 kg (229 lb) 58160896 211-089-0609-B48-E0, 40-08	Not needed	Not needed
OR <b>Floating spindle</b> 89 mm (3 1/2") API 3 1/2" IF PIN x 2 3/8" IF BOX 648 mm (25 1/2") N/A 57735235 ADS Product	89 mm (3 1/2") API 2 3/8" IF PIN x 2 3/8" IF PIN N/A N/A 557922478 ADS Product			

114 mm (4 1/2") OD drill string, API 2 7/8" IF. For 134 - 222 mm (5 1/4"-8 3/4") holes				
Spindle	Saver sub	Drill pipe	Adapter	Drill collar*
<b>Fixed spindle</b> 114 mm (4 1/2") API 3 1/2" IF BOX x 2 3/8" IF PIN 1,061 mm (40") N/A 57699621 ADS Product	Not needed	114 mm (4 1/2") API 2 7/8" IF BOX x PIN 6.09 m (20 ft) 158 kg (348 lb) 57690448 213-114-0610-B48-L0,40-08	Not needed	Not needed
OR <b>Floating spindle</b> 114 mm (4 1/2") API 3 1/2" IF PIN x 2 3/8" IF BOX 648 mm (25 1/2") N/A 57735235 ADS Product	114 mm (4 1/2") API 2 7/8" IF PIN x 2 7/8" IF PIN 508 mm (20") N/A 57735243 ADS Product		114 mm (5") API 2 7/8" IF BOX x 3 1/2" IF PIN 610 mm (24") 37 kg (82 lb) 58171448 313-2114-15-053-01-D48,41	127 mm (5") API 3 1/2" IF BOX x PIN 6,09 m (20 ft) 463 kg (1,021 lb) 58219254 215-8860-48,55-32
			140 mm (5 1/2") API 2 7/8" IF BOX x 4" FH PIN 240 mm (9 1/2") 24 kg (53 lb) 57620544 313-2140-21-024-01-D00,80	140 mm (5 1/2") API 4" FH BOX x PIN 6,09 m (20 ft) 604 kg (1,332 lb) 58219262 221-8960-48,55-40





Adapter / Bit sub	DTH hammer	DTH bit size	WOB**
89 mm (3½") API 2¾" Reg BOX x API 2¾" IF BOX 508 mm (20") 17 kg (37 lb) 58135732 311-1089-10-051-01-D00,41	<b>QLX 40</b> 102 mm (4") API 2¾" Reg PIN 897 mm (35½") 46 kg (100 lb) 89010117 9704-QX-00-10P-64-000	110 - 130 mm 4⅝" - 5⅛"	1,200 kg
89 mm (3½") API 3½" Reg BOX x API 2¾" IF BOX 508 mm (20") 15 kg (33 lb) 58135880 311-1089-14-051-01-K48,41	<b>QLX 50</b> 122 mm (4⅜") API 3½" Reg PIN 1,061 mm (41¾") 69 kg (153 lb) 89010092 9705-QX-00-14P-64-000	134 - 152 mm 5¼" - 6"	1,500 kg

**Legend****Description:**

OD, mm:

Thread:

Length, (s/s):

Weight:

**Prod. No.:****Prod. code:**

\* Add quantity of drill collar  
to match the recommended  
weight on bit

\*\* Weight On Bit

Adapter / Bit sub	DTH hammer	DTH bit size	WOB**
114 mm (4½") API 3½" Reg BOX x API 2¾" IF BOX 508 mm (20") 27 kg (60 lb) 58135849 313-1114-14-051-01-E48,41	<b>QLX 50</b> 122 mm (4⅜") API 3½" Reg PIN 1,061 mm (41¾") 69 kg (153 lb) 89010092 9705-QX-00-14P-64-000	134 - 152 mm 5½" - 6"	1,500 kg
127 mm (4¾") API 3½" Reg BOX x 3½" IF BOX 508 mm (20") 18 kg (40 lb) 89010494 315-1127-14-051-01-K48,41	<b>QLX 60</b> 142 mm (5⅝") API 3½" Reg PIN 1,091 mm (42⅞") 93 kg (205 lb) 52352465 9706-QX-00-14P-64-000	152 - 203 mm 6 - 8"	2,200 kg
140 mm (5½") API 4½" Reg BOX x 3½" IF BOX 610 mm (24") 58220039 317-1140-15-054-01-D48,80	<b>TD80 Std</b> 181 mm (7⅛") API 4½" Reg PIN 1,466 mm (57⅞") 216 kg (476 lb) 52328127 9708-QT-00-17P-29-000	200 - 222 mm 7⅞" - 8¾"	3,000 kg

# Atlas Copco TH60, T3W drill rigs

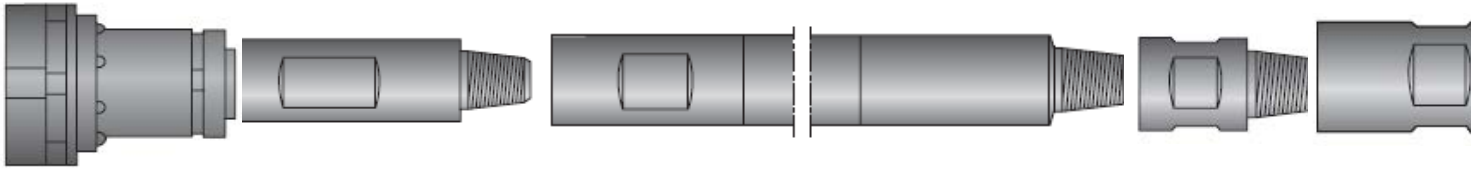

**TH60, TH60 DH, T3W, T3W DH Rotation unit thread connection: API 3 1/2" IF PIN**  
 114 mm (4 1/2") OD drill string, API 3 1/2" Reg. For 134 - 222 mm (5 1/4" - 8 3/4") holes

Spindle adapter	Saver sub	Drill pipe	Adapter	Drill collar*
<b>Fixed spindle adapter</b> 114 mm (4 1/2") API 3 1/2" IF BOX x 3 1/2" Reg PIN 1,061 mm (40") N/A 57867160 ADS Product	Not needed	114 mm (4 1/2") API 3 1/2" Reg BOX x PIN 6.09 m (20 ft) 156 kg (344 lb) 58160912 214-114-0609-B48-E0,40-08	Not needed	Not needed
			127 mm (5") API 3 1/2" Reg BOX x 3 1/2" IF PIN 610 mm (24") 65 kg (143 lb) 52162591 314-2140-15-061-01-E00,41	127 mm (5") API 3 1/2" IF BOX x PIN 6.09 m (20 ft) 463 kg (1,021 lb) 58219254 215-8860-48,55-32
OR <b>Floating spindle adapter</b> 114 mm (4 1/2") 92004334 Secoroc Product	114 mm (4 1/2") API 3 1/2" Reg PIN x 3 1/2" Reg PIN 508 mm (20") 43 kg (67 lb) 92004487 Secoroc Product	114 mm (4 1/2") API 3 1/2" Reg BOX x PIN 6.09 m (20 ft) 156 kg (344 lb) 58160912 214-114-0609-B48-E0,40-08	140 mm (5 1/2") API 3 1/2" Reg BOX x 4" FH PIN 270 mm (10 5/8") 30 kg (66 lb) 52165610 314-2140-21-027-11-K00,80	140 mm (5 1/2") API 4" FH BOX x PIN 6.09 m (20 ft) 604 kg (1,332 lb) 58219262 221-8960-48,55-40
			140 mm (5 1/2") API 3 1/2" Reg BOX x 4" FH PIN 270 mm (10 5/8") 30 kg (66 lb) 52165610 314-2140-21-027-11-K00,80	140 mm (5 1/2") API 4" FH BOX x PIN 6.09 m (20 ft) 604 kg (1,332 lb) 58219262 221-8960-48,55-40







Adapter / Bit sub	DTH hammer	DTH bit size	WOB**
114 mm (4 1/2") API 3 1/2" Reg BOX x BOX 508 mm (20") 27 kg (60 lb) 58135823 314-1114-14-051-01-E48,41	QLX 50 122 mm (4 7/8") API 3 1/2" Reg PIN 1,061 mm (41 3/4") 69 kg (153 lb) 89010092 9705-QX-00-14P-64-000	134-152 mm 5 1/4"-6"	1,500 kg
127 mm (4 3/4") API 3 1/2" Reg BOX x 3 1/2" IF BOX 508 mm (20") 18 kg (40 lb) 89010494 315-1127-14-051-01-K48,41	QLX 60 142 mm (5 5/8") API 3 1/2" Reg PIN 1,091 mm (42 15/16") 93 kg (205 lb) 52352465 9706-QX-00-14P-64-000	152-203 mm 6-8"	2,200 kg
140 mm (5 1/2") API 4 1/2" Reg BOX x 3 1/2" IF BOX 610 mm (24") 21 kg (46 lb) 58220039 317-1140-15-054-01-D48,80	TD80 Std 181 mm (7 1/8") API 4 1/2" Reg PIN 1,466 mm (57 1/16") 216 kg (476 lb) 52328127 9708-QT-00-17P-29-000	200-222 mm 7 7/8" - 8 3/4"	3,000 kg

**Legend**

**Description:**  
 OD, mm:  
 Thread:  
 Length, (s/s):  
 Weight:  
**Prod. No.:**  
**Prod. code:**

*\* Add quantity of drill collar to match the recommended weight on bit*

**\*\* Weight On Bit**

**Up-hole velocity**

Up-hole velocity depends on available air volume, bit/hole size and pipe OD. The cutting speed should be at least 20 m/s in order to keep the hole clean. A too high speed will result in excessive wear on the drill string. Our recommended up-hole velocity is 30-50 m/s.

**Up-hole velocity per hole range and compressor size (89 mm OD pipes)**

Hole Size	423 L/s / 24,1 bar (900 cfm / 350 psi)	505 L/s / 24,1bar (1070 cfm / 350 psi)
134 - 152 mm (5 1/4" - 6")	54 - 35 m/s (10,568 - 6,985 fpm)	64 - 42 m/s (12,616 - 8,339 fpm)

**Up-hole velocity per hole range and compressor size (114 mm OD pipes)**

Hole Size	423 L/s / 24,1 bar (900 cfm / 350 psi)	505 L/s / 24,1bar (1070 cfm / 350 psi)
134 - 152 mm (5 1/4" - 6")	190 - 53 m/s (2,380 - 10,491 fpm)	130 - 64 m/s (25,525 - 12,525 fpm)
152 - 203 mm (6 - 8")	53 - 19 m/s (10,491 - 3,759 fpm)	64 - 23 m/s (12,525 - 4,487 fpm)
200 - 222 mm (7 7/8" - 8 3/4")	20 - 15 m/s (3,927 - 2,922 fpm)	24 - 18 m/s (4,688 - 3,489 fpm)

# Atlas Copco T4W drill rigs

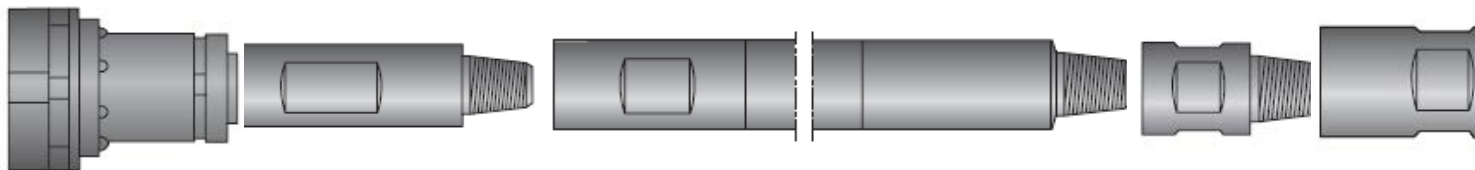

T4W, T4W DH Rotation unit thread connection: API 4" IF BOX 114 mm (4 1/2") OD drill string, API 2 7/8" IF. For 134–254 mm (5 1/4" - 10.00") holes			
Spindle	Drill pipe	Adapter	Drill collar*
<p><b>Fixed spindle (Spur gear head)</b>                      114 mm (4 1/2" in)                      API 4" FH PIN x 2 7/8" IF BOX                      483 mm (19")                      51 kg (112 lb)                      57093171 ADS Product</p>	<p>114 mm (4 1/2")                      API 2 7/8" IF BOX x PIN                      7.62 m (25 ft)                      187 kg (412 lb)                      52202033                      213-114-0762-B45-D0,40-08</p>	<p>Not needed</p>	<p>114 mm (4 1/2")                      API 2 7/8" IF BOX x PIN                      7.62 m (25 ft)                      298 kg (657 lb)                      52202454                      213-114-0762-B45-D0,55-16</p>
<p><b>Floating spindle (Worm gear head)</b>                      114 mm (4 1/2")                      API 4" FH PIN x 2 5/8" IF BOX                      381 mm (15")                      55 kg (121 lb)                      52211638 ADS Product</p>	<p>114 mm (4 1/2")                      API 2 7/8" IF BOX x PIN                      7.62 m (25 ft)                      187 kg (412 lb)                      52202033                      213-114-0762-B45-D0,40-08</p>	<p>140 mm (5 1/2")                      API 4" FH BOX x 2 7/8" IF PIN                      610 mm (24")                      37 kg (82 lb)                      52215456                      321-2140-13-061-01-D00,80</p>	<p>140 mm (5 1/2")                      API 4" FH BOX x PIN                      7,015 mm (23 ft)                      730 kg (1,609 lb)                      52266160                      213-114-0762-B45-D0,55-16</p>





Adapter / Bit sub	DTH hammer	DTH bit size	WOB**
114 mm (4½") API 3½" Reg BOX x API 2⅞" IF PIN 610 mm (24") 39 kg (86 lb) 52224300 314-2114-13-061-01-E00,41	<b>QLX 50</b> 122 mm (4 13⁄16") API 3½" Reg PIN 1,061 mm (41 ¾") 69 kg (153 lb) 89010092 9705-QX-00-14P-64-000	134 - 152 mm 5¼ - 6"	1,500 kg
140 mm (5½") API 4" FH PIN x 3½" Reg BOX 610 mm (24") 65 kg (143 lb) 92003775 314-2140-21-061-03-E45,82	<b>QLX 60</b> 142 mm (5 19⁄32") API 3½" Reg PIN 1,091 mm (42 15⁄16") 93 kg (205 lb) 52352465 9706-QX-00-14P-64-000	152 - 203 mm 6 - 8"	2,200 kg
140 mm (5½") API 4" FH PIN x 4½" Reg BOX 610 mm (24") 57 kg (126 lb) 50624105 317-2140-21-061-11-E48,80	<b>TD80 Std</b> 181 mm (7 1⁄8") API 4½" Reg PIN 1,466 mm (57 1⁄16") 216 kg (476 lb) 52328127 9708-QT-00-17P-29-000	200 - 254 mm 7⅞ - 10"	3,000 kg
197 mm (7¾") API 4" FH PIN x 6⅝" Reg BOX 610 mm (24") 90 kg (198 lb) 50624097 318-2197-19-061-11-E48,80	<b>QL 120 Std</b> 285 mm (11 ¼") API 6⅝" Reg PIN 1,837 mm (72 9⁄16") 650 kg (1,433 lb) 52107448 9712-QL-00-18P-65-000	311 - 560 mm 12¼ - 22 1⁄16"	4,000 kg

**Legend**

**Description:**

OD, mm:

Thread:

Length, (s/s):

Weight:

**Prod. No.:**

**Prod. code:**

\* Add quantity of drill collar to match the recommended weight on bit

\*\* Weight On Bit



# Atlas Copco T4W drill rigs

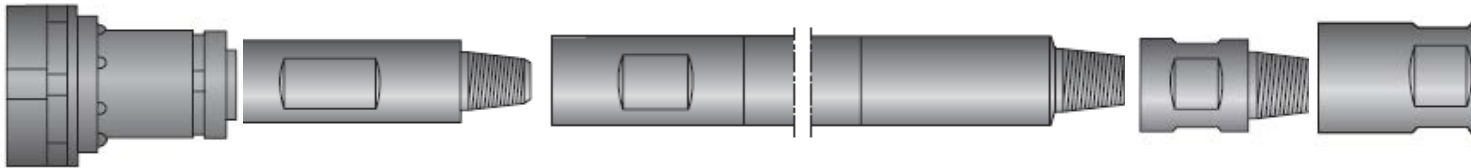

**T4W, T4W DH Rotation unit thread connection: API 4" IF BOX**  
 114mm (4 1/2") OD drill string, API 3 1/2" Reg. For 134-54mm (5 1/4" - 10.00") holes

Spindle	Drill pipe	Adapter	Drill collar*
<p><b>Fixed spindle (Spur gear head)</b>                      114 mm (4 1/2" in)                      API 4" FH PIN x 3 1/2" Reg BOX                      483 mm (19")                      51 kg (112 lb)                      52150422 ADS Product</p>	<p>114 mm (4 1/2")                      API 3 1/2" Reg BOX x PIN                      7.62 m (25 ft)                      187 kg (412 lb)                      50425859                      214-114-0762-B45-D0,40-08</p>	<p>Not needed</p>	<p>114 mm (4 1/2")                      API 3 1/2" Reg BxP                      7.62 m (25 ft)                      365 kg (805 lb)                      50262187                      214-114-0762-B45-D0,A-16</p>
<p><b>Floating spindle (Worm gear head)</b>                      114 mm (4 1/2")                      API 4" FH PIN x 3 1/2" Reg BOX                      381 mm (15")                      23 kg (51 lb)                      52162302 ADS Product</p>	<p>114 mm (4 1/2")                      API 3 1/2" Reg BOX x PIN                      7.62 m (25 ft)                      187 kg (412 lb)                      50425859                      214-114-0762-B45-D0,40-08</p>	<p>140 mm (5 1/2")                      API 4" FH BOX x 3 1/2" Reg PIN                      610 mm (24")                      39 kg (86 lb)                      52145265                      321-2140-14-061-01-D00,80</p>	<p>140 mm (5 1/2")                      API 4" FH BOX x PIN                      7,015 mm (23 ft)                      730 kg (1609 lb)                      52266160                      213-114-0762-B45-D0,55-16</p>





Adapter / Bit sub	DTH hammer	DTH bit size	WOB**
Not needed	<b>QLX 50</b> 122 mm (4 13/16") API 3 1/2" Reg PIN 1,061 mm (41 3/4") 69 kg (153 lb) 89010092 9705-QX-00-14P-64-000	134 - 152 mm 5 1/4 - 6"	1,500 kg
	<b>QLX 60</b> 142 mm (5 19/32") API 3 1/2" Reg PIN 1,091 mm (42 15/16") 93 kg (205 lb) 52352465 9706-QX-00-14P-64-000	152 - 203 mm 6 - 8"	2,200 kg
140 mm (5 1/2") API 4" FH PIN x 4 1/2" Reg BOX 610 mm (24") 57 kg (126 lb)	<b>TD 80 Std</b> 181 mm (7 1/8") API 4 1/2" Reg PIN 1,466 mm (57 11/16") 216 kg (476 lb) 52328127 9708-QT-00-17P-29-000	200 - 254 mm 7 7/8 - 10"	3,000 kg
197 mm (7 3/4") API 4" FH PIN x 6 5/8" Reg BOX 610 mm (24") 90 kg (198 lb)	<b>QL 120 Std</b> 285 mm (11 1/4") API 6 5/8" Reg PIN 1,837 mm (72 3/16") 650 kg (1,433 lb) 52107448 9712-09-50-00	311 - 560 mm 12 1/4 - 22 1/16"	4,000 kg

**Legend**

**Description:**

OD, mm:  
Thread:  
Length, (s/s):  
Weight:

**Prod. No.:**

**Prod. code:**

\* Add quantity of drill collar to match the recommended weight on bit

\*\* Weight On Bit

**Up-hole velocity**

Up-hole velocity depends on available air volume, bit/hole size and pipe OD. The cutting speed should be at least 20 m/s in order to keep the hole clean. A too high speed will result in excessive wear on the drill string. Our recommended up-hole velocity is 30-50 m/s.

**Up-hole velocity per hole range and compressor size (114 mm OD pipes)**

Hole Size	505 L/s / 24,1 bar (1070 cfm / 350 psi)	590 L/s / 24,1 bar (1250 cfm / 350 psi)
134 - 152 mm (5 1/4 - 6")	130 - 64 m/s (25,525 - 12,525 fpm)	152 - 74 m/s (29,821 - 14,633 fpm)
152 - 203 mm (6 - 8")	64 - 23 m/s (12,525 - 4,487 fpm)	74 - 27 m/s (14,633 - 5,243 fpm)
200 - 254 mm (7 7/8 - 10")	24 - 12 m/s (4,688 - 2,457 fpm)	28 - 15 m/s (5,477 - 2,871 fpm)

# Secoroc down-the-hole rock drilling tools

Down-the-hole hammers												
Description	Product No	Product code	Thread connection	Outside diameter		Rec. Hole size		Shank style	Length without bit, s-s		Weight without bit	
				mm	inch	mm	inch		mm	inch	kg	lb
4"												
QLX 40	89010117	9704-QX-00-10P-64-000	API 2 3/8" Reg PIN	102	4	110 - 130	4 1/16 - 5 1/8	QLX 40	897	35 1/2	46	88100
QL 340	92050412	9704-QL-00-10P-34-000	API 2 3/8" Reg PIN					QL 340			41	
COP 44	89000482	9704-CO-00-10P-34-000	API 2 3/8" Reg PIN	98	3 7/8	110 - 125	4 3/8 - 4 15/16	DHD 340	1,034	40 1/16	38	84
5"												
QLX 50	89010092	9705-QX-00-14P-64-000	API 3 1/2" Reg PIN	122	4 7/16	133 - 152	5 1/4 - 6	QL 50	1,061	41 3/4	69	153
COP 54	89000481	9705-CO-00-14P-37-000	API 3 1/2" Reg PIN	120	4 3/4	134 - 152	5 1/4 - 6	DHD 350	1,145	45	57	126
COP 54 GOLD	89001243	9705-CG-00-14P-25-000	API 3 1/2" Reg PIN	120	4 3/4	134 - 152	5 1/4 - 6	QL 50	1,194	47	66	146
6"												
QLX 60	52352465	9706-QX-00-14P-64-000	API 3 1/2" Reg PIN	142	5 5/16	152 - 191	6 - 7 1/2	QL 60	1,091	43	93	205
QL 60	52324258	9706-QL-00-14P-26-000	API 3 1/2" Reg PIN	138	5 5/16	152 - 191	6 - 7 1/2	QL 60	1,132	44 1/2	91	201
QL 60	52315116	9706-QL-00-13P-26-000	API 2 7/8" IF PIN	138	5 5/16	152 - 191	6 - 7 1/2	QL 60	1,132	44 1/2	91	201
COP 64	89000486	9706-CO-00-14P-59-000	API 3 1/2" Reg PIN	142	5 5/16	156 - 178	6 1/8 - 7	DHD 360	1,308	5 1/2	95	209
COP 64 GOLD	89000959	9706-CG-00-14P-26-000	API 3 1/2" Reg PIN	142	5 5/16	156 - 178	6 1/8 - 7	QL 60	1,258	49 1/2	96	212
8"												
TD 80 STD	52328127	9708-QT-00-17P-29-000	API 4 1/2" Reg PIN	181	7 1/8	200 - 305	7 7/8 - 12	QL 80	1,466	57 3/8	216	476
QL 80 STD	52083623	9708-QL-00-17P-29-000	API 4 1/2" Reg PIN	181	7 1/8	200 - 305	7 7/8 - 12	QL 80	1,461	57 1/2	203	448
QL 80 HYDRO-CYCLONE	52083656	9708-QL-00-17P-29-0H0	API 4 1/2" Reg PIN	181	7 1/8	200 - 305	7 7/8 - 12	QL 80	1,567	61 3/8	203	448
12"												
QL 120 STD	52107448	9712-09-50-00	API 6 3/8" Reg PIN	285	11 1/4	311 - 560	12 1/4 - 22 1/16	QL 120	1,837	72 1/2	650	1,433

Other hammer executions / thread connections are available.



## Guide to hammer features

STD	Standard	Standard hammer
QM	Quarry Mining	Designed for mining, back reaming buttons and thick casing
DH	Deephole	Designed for deephole drilling
OG	Oil & Gas	Designed for oil and gas drilling
BO	Break out washers	Equipped with breakout washers in both ends



# Secoroc drill bits – standard assortment

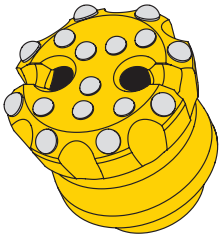

### Flat front

**Applications:**  
Hard and abrasive formations, all round.

**Typical formations:**  
Granite, hard limestone, basalt.

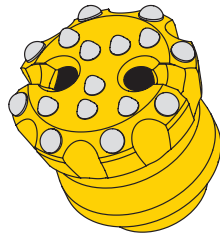

### SpeedBit

**Applications:**  
Medium hard to hard and abrasive formations. For higher productivity.

**Design feature:**  
Ballistic buttons in front.

**Typical formations:**  
Granite, hard limestone, basalt.

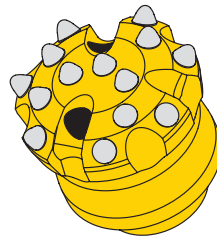

### Convex front, ballistic

**Applications:**  
Soft to medium hard rock. Non abrasive formations. High penetration rate.

**Typical formations:**  
Limestone, hard limestone, shale.

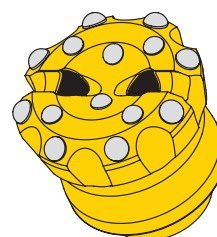

### Concave front

**Applications:**  
Medium hard to hard formations. Less abrasive, fractured formations. Excellent control over hole deviation.

**Design feature:**  
HD - larger gauge buttons. DGR - double (overlapping) gauge row. Only from 8".

**Typical formations:**  
Granite, hard limestone, basalt.

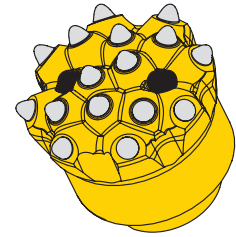

### Rocket bit

**Applications:**  
Soft to medium hard formations. For exceptional productivity. Fractured rock.

**Design feature:**  
Spherical buttons for hard and abrasive formations. Ballistic buttons for soft formations.

**Typical formations:**  
Limestone, hard limestone.

Drill bits for QLX 40 (TD 40 shank)			
Diameter		Weight approx	
mm	Inch	kg	lb
FLAT FRONT			
110	4 5/16	9	20
115	4 1/2	9	21
120	4 3/4	10	21
125	4 15/16	10	22
130	5 1/8	10	23
SPEEDBIT			
110	4 5/16	9	20
115	4 1/2	9	21
120	4 3/4	10	21
125	4 15/16	10	22
130	5 1/8	10	22
CONCAVE			
115	4 1/2	9	20
121	4 3/4	9	21
ROCKET BIT - BALLISTIC			
110	4 15/16	9	19
115	4 1/2	9	19
FOOT VALVE			
ASSEMBLY TOOL			

Drill bits for QLX 50 (QL 50 shank)			
Diameter		Weight approx	
mm	Inch	kg	lb
FLAT FRONT			
130	5 1/8	16	35
134	5 1/4	16	36
140	5 1/2	17	37
149	5 7/8	17	38
152	6	18	39
SPEEDBIT			
134	5 1/4	16	36
140	5 1/2	17	37
CONCAVE			
130	5 1/8	16	35
134	5 1/4	16	36
140	5 1/2	16	36
146	5 3/4	17	38
149	5 7/8	18	39
152	6	18	39
CONVEX BALLISTIC			
130	5 1/8	16	35
140	5 1/2	16	36
140	5 1/2	16	36
146	5 3/4	17	38
FOOT VALVE			
ASSEMBLY TOOL			

# Secoroc down-the-hole rock drilling tools

Drill bits for QLX 60 & TD 70 (QL 60 shank)			
Diameter		Weight approx	
mm	Inch	kg	lb
FLAT FRONT			
152	6	22	49
156	6 1/8	23	50
159	6 1/4	23	50
165	6 1/2	24	53
171	6 3/4	25	55
203	8	32	70
SPEEDBIT			
156	6 1/8	23	50
165	6 1/2	24	54
171	6 3/4	25	55
CONCAVE			
152	6	22	49
156	6 1/8	22	49
159	6 1/4	23	50
165	6 1/2	24	53
171	6 3/4	24	53
171	6 3/4	25	55
203	8	35	78
CONVEX BALLISTIC			
165	6 1/2	24	52
171	6 3/4	25	54
203	8	35	78
CONVEX SPHERICAL			
165	6 1/2	24	54
171	6 3/4	25	54
FOOT VALVE			
ASSEMBLY TOOL			

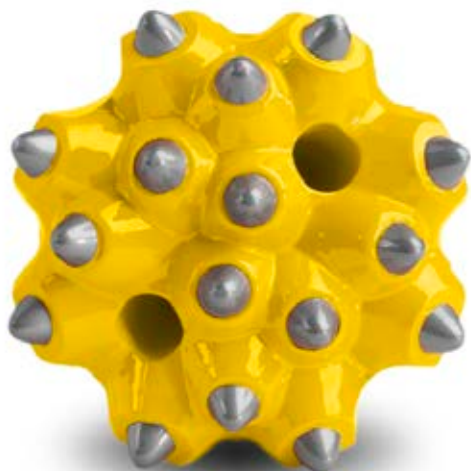

Drill bits for TD 80 (QL 80 shank)			
Diameter		Weight approx	
mm	Inch	kg	lb
FLAT FRONT			
241	9 1/2	60	132
254	10	63	138
CONCAVE			
203	8	49	107
222	8 3/4	54	118
225	8 7/8	54	118
251	9 7/8	59	130
CONVEX-CONCAVE			
200	7 7/8	48	107
203	8	49	107
216	8 1/2	50	110
219	8 5/8	51	112
222	8 3/4	54	120
225	8 7/8	55	121
254	10	61	135
279	11	78	173
305	12	84	185
FOOT VALVE			
ASSEMBLY TOOL			

Drill bits for QL 120 (QL 120 shank)			
Diameter		Weight approx	
mm	Inch	kg	lb
CONCAVE			
311	12 1/4	202	446
314	12 3/8	203	447
330	13	195	431
343	13 1/2	201	444
349	13 3/4	204	449
375	14 3/4	239	526
391	15 3/8	243	536
343	13 1/2	201	444
391	15 3/8	243	536
451	17 3/4	288	635
457	18	287	632
464	18 1/4	298	658
508	20	342	753
FOOT VALVE			
PIN DRIVE			



## Pipes - Design group TH60 (T2, T3, TH60/75E/100A)

Diameter		Thread Pin/Box	Component	Wall thickness		Length		Wrench flats		Flat location	Hex		Weight	
mm	inch			mm	inch	m	ft	mm	inch		mm	inch	kg	lb
89	3.50	API 2 3/8" IF	Pipe	9	0.368	6.10	20	70	2.75	Box only	No	No	104	229
114	4.50	API 2 7/8" IF	Pipe	9	0.337	6.10	20	89	3.50	Box only	No	No	156	344
114	4.50	API 3 1/2" Reg	Pipe	9	0.337	6.10	20	89	3.50	Box only	No	No	156	344
114	4.50	API 3 1/2" IF	Pipe	9	0.337	6.10	20	89	3.50	Box only	No	No	156	344

## Pipes - Design group T4 (T4W, T4W DH)

Diameter		Thread Pin/Box	Component	Wall thickness		Length		Wrench flats		Flat location	Hex		Weight	
mm	inch			mm	inch	m	ft	mm	inch		mm	inch	kg	lb
102	4.00	API 2 3/8" Reg	Pipe	9	0.337	7.62	25	89	3.50	Pin only	89	3.50	191	421
114	4.50	API 2 7/8" IF	Pipe	9	0.337	7.62	25	89	3.50	Pin only	102	4.00	187	412
114	4.50	API 3 1/2" Reg	Pipe	9	0.337	7.62	25	89	3.50	Pin only	102	4.00	187	412
114	4.50	API 2 7/8" IF	Pipe/Collar	16	0.625	7.62	25	89	3.50	Pin only	102	4.00	298	657
114	4.50	API 3 1/2" Reg	Pipe/Collar	16	0.625	7.62	25	89	3.50	Pin only	102	4.00	365	805
127	5.00	API 3 1/2" Reg	Pipe	10	0.375	7.62	25	89	3.50	Pin only	102	4.00	255	562
140	5.50	API 4" FH	Pipe	11	0.415	7.62	25	114	4.50	Pin only	114	4.50	333	734

## Drill collars

Diameter		Thread Pin/Box	Component	Wall thickness		Length		Wrench flats		Flat location	Hex		Weight	
mm	inch			mm	inch	m	ft	mm	inch		mm	inch	kg	lb
127	5.00	API 3 1/2" IF	Collar	32	1.26	6.10	20	89	3.50	Pin & Box	No	No	463	1,021
140	5.50	API 4" FH	Collar	40	1.575	6.10	20	114	4.50	Pin & Box	No	No	604	1,332
140	5.50	API 4" FH	Collar	40	1.575	7.02	23	114	4.50	Pin only	114	4.50	730	1,609

## Stabilizers

Hole size		OD		Length		Weight		Neck /Body OD		Thread connection	
mm	inch	mm	inch	mm	ft	kg	lb	mm	inch	Box	Pin
200	7 7/8	191	7 1/2	3,660	12	420	926	114	4 1/2	API 4 1/2" Reg	API 4" FH
200	7 7/8	191	7 1/2	3,660	12	360	794	140	5 1/2	API 4 1/2" Reg	API 4 1/2" Reg
200	7 7/8	191	7 1/2	6,100	20	360	794	140	5 1/2	API 4 1/2" Reg	API 4" FH
200	7 7/8	191	7 1/2	6,100	20	360	794	140	5 1/2	API 4 1/2" Reg	API 4 1/2" Reg
251	9 7/8	241	9 1/2	3,660	12	780	1,720	203	8	API 6 5/8" Reg	API 6 5/8" Reg
251	9 7/8	241	9 1/2	6,100	20	680	1,499	203	8	API 6 5/8" Reg	API 6 5/8" Reg
311	12 1/4	302	11 7/8	3,660	12	1050	2,315	203	8	API 6 5/8" Reg	API 6 5/8" Reg
311	12 1/4	302	11 7/8	6,100	20	805	1,775	203	8	API 6 5/8" Reg	API 6 5/8" Reg
381	15	375	14 3/4	3,660	12	1250	2,756	203	8	API 6 5/8" Reg	API 6 5/8" Reg

## Lifting bails

Thread connection	Class, kg (lb)
API 2 6/8" Reg	-
API 3 1/2" Reg	3,600 (7 900)
API 4 1/2" Reg	3,600 (7 900)
API 6 5/8" Reg	3,600 (7 900)
API 2 7/8" IF	3,600 (7 900)
API 4" FH	3,600 (7 900)

## Lifting plugs

Thread connection	Class, kg (lb)
API 2 3/8" IF	16,000 (35,000)
API 2 7/8" IF	16,000 (35,000)
API 3 1/2" IF	16,000 (35,000)
API 3 1/2" Reg	16,000 (35,000)
API 4" FH	-

## Adapters – Box x Box

Diameter		Length		Thread connection		Flats across		Weight	
mm	inch	mm	inch	Box		mm	inch	kg	lb
89	3½	508	20	API 2¾" Reg	API 2¾" IF	70	2.75	17	37
89	3½	508	20	API 3½" Reg	API 2¾" IF	70	2.75	15	33
114	4½	508	20	API 3½" Reg	API 2½" IF	89	3.50	27	60
127	4¾	508	20	API 3½" Reg	API 3½" IF	89	3.50	18	40

## Adapters – Pin x Box

Diameter		Length		Thread connection		Flats across		Weight	
mm	inch	mm	inch	Box		mm	inch	kg	lb
114	4½	610	24	API 3½" Reg	API 2½" IF	89	3.50	39	86
140	5½	610	24	API 4½" Reg	API 4" FH	114	4.50	57	126
140	5½	610	24	API 4" FH	API 3½" Reg	114	4.50	39	86
140	5½	610	24	API 3½" Reg	API 4" FH	114	4.50	65	143
197	7¾	610	24	API 6½" Reg	API 4" FH	114	4.50	90	198

## In-line Check Valves

Diameter		Length		Thread connection		Flats across		Weight		Air intake configuration
mm	inch	mm	inch	Box		mm	inch	kg	lb	
Reg	3½"	300	11 4/5	2½" IF	2½" IF	70	2.75	15	33	PIN down
114	4½"	300	11 4/5	2½" IF	2 7/8" IF	89	3.50	18	40	PIN down
114	4½"	610	24	API 2½" IF	API 2½" IF	89	3.50	39	86	PIN up
114	4½"	610	24	API 3½" Reg	API 3½" Reg	89	3.50	40	88	PIN up
140	5½"	380	15	3½" Reg	3½" Reg	114	4.50	34	75	PIN down









# Parts and Services

Wherever you are in the world, as an Atlas Copco customer your service experience will always be the same. It's all about our commitment, our service promise, our capability and our quality. Furthermore, we aim to increase your productivity. This is the difference that is Atlas Copco Parts and Services. It's not just about our promises, it's about delivery.

## Extended warranty

Peace of mind for three years with no small print. Let us protect your investment.

### Features

- Three years, unlimited operating hours
- Follow Atlas Copco maintenance schedule
- Atlas Copco genuine parts and selected oils and lubricants
- Planned audits

### Benefits

- Focus on your production
- Preventive maintenance
- Meet warranty conditions
- Assures rig reliability

## Service agreements

Best-in-class maintenance to ensure reliability and highest availability of your drilling equipment.

### Features

- Total maintenance
- Preventive maintenance
- Fixed-price repair
- Parts-only plans

### Benefits

- Minimize unplanned repairs
- Lowest operating cost
- Extended warranty period
- Genuine Atlas Copco parts and selected lubricants

## Preventive and corrective maintenance kits

Atlas Copco genuine parts are manufactured to the same exacting quality standards as your drill rig.

### Features

- Guaranteed performance
- Quality inspected and tested
- Available through our state-of-the-art distribution system

### Benefits

- Warranted between scheduled services
- Ensured reliability and highest availability
- Quick, accurate order fulfillment

## Atlas Copco Fluids

Atlas Copco Fluids are produced to the exacting specifications required to meet the demands of your drilling application.

### Features

- Designed for the toughest environment
- Performance tested
- Ensure extended warranty

### Benefits

- Protect your investment
- Optimize service life
- Save money, minimize breakdowns



## Fluid Management

Safer, cleaner reliability.

### Features

- Hydraulic hose first aid kit
- Hydraulic filter cart
- Atlas Copco premium air hose
- International expertise

### Benefits

- Limit downtime
- Maintain clean, efficient systems
- Safety and reliability
- Superior productivity

## Hydraulic hose first aid kit

Each kit provides an immediate replacement for every hydraulic hose on your drill rig.

### Features

- Drill rig specific hoses and adaptors
- Complete instructions and accessories
- Environmentally friendly
- Wheel or truck mountable

### Benefits

- Fastest possible fix
- First time fix at the jobsite
- Spillage control
- Highly mobile

## Diesel fuel filter cart

A portable fuel cleaning system designed to protect your investment.

### Features

- Controls particulate ingestion
- Prevents water contamination
- Easy spin-on replacement elements

### Benefits

- Maximize usable life of engine components
- Minimize downtime
- Lower maintenance cost

## Hydraulic filter cart

A superior contamination control device designed with maximum protection in mind.

### Features

- Multi-stage filtration
- Highest quality components
- Flexible configurations
- Easy spin-on replacement elements

### Benefits

- Prevents secondary failures
- Safety and reliability
- Matched to your specific needs
- Save time, save money



# Our presence marks The Difference

Atlas Copco equipment is built to last. Delivering superior performance in the most efficient and cost effective manner, our equipment is the driving force in your business. At Atlas Copco Service we are committed to delivering superior service to all customers in the Mining and Rock Excavation industry – whenever, wherever.

We act as the most competent speaking-partner regarding the operation of your equipment. We enhance your productivity, profitability, and peace of mind, ensuring successful and sustainable business relationships. We always put safety and environmental considerations first in everything we do.

## Technical support that stands out

We know that the moments-of-truth are at delivery, upon start-up and in operation.

It is here that the difference between those who keep their promises and those who do not comes to light.

Our dedication to providing the best possible support comes from recognizing the impact this has on success or failure. Wherever you are in the world, we strive to ensure that your service experience will be consistent.

## Safety and environment

The concern for safety and the environment is more prominent today than ever before.

Atlas Copco's concern for safety and the environment are essential components of our commitment to sustainable productivity.

Our equipment and genuine parts are designed to maximize the safety of personnel and mining operations, and to minimize environmental impact.





# Reliability and the highest availability

## Service agreements

Atlas Copco provides several types of service agreements to meet operational requirements and to secure your productivity.

**Extended warranty** – Peace of mind, protecting your investment

**Parts-only plan** – Genuine Atlas Copco parts and lubricants, guaranteed performance

**Preventive maintenance programs** – Lower life cycle cost ensuring availability

**Total maintenance programs** – minimize unplanned repairs

**Reliability centered maintenance products** – Non-intrusive equipment health check

## Service kits

To ensure your equipment remains fit for purpose, two things are needed: a good preventive maintenance schedule and a strict, genuine parts policy. Atlas Copco genuine parts help preserve the superior quality of the products throughout their entire life-cycle.

Quality tested and inspected to ensure reliability and highest availability

All required parts in one kit to minimize service time

## Remanufactured Components

When you use Atlas Copco remanufactured components, you can rest assured that we will have the part you need – in stock – when you need it.

**Genuine OEM parts** – Safe, reliable performance

**Superior warranty** – Peace of mind – Lower operating cost

**Components readily available** – Sustainable productivity

**Recycle** – Reduce environmental impact









## Trained people perform

**Atlas Copco provides the very best training as part of our customer service, and appreciates the difference between operators who are already experts at handling our equipment and those who need additional training.**

We are more than willing to share the benefits of our long experience in the market and our complete toolbox of best practices, to the benefit of all our customers. Thanks to well-trained staff we are able to offer you Atlas Copco's premium service support. Our service technicians go through a rigorous certification process, ensuring that you always get the best possible technical support close-by, readily available, whenever needed.

## Just what you need, right when you need it

**Atlas Copco aims for a highly efficient supply chain enabling fast, demand-driven distribution.**

Together with our customers and our international supply chain network we continuously strive to supply through the most economic and environmentally-friendly mode of transportation.

Complete, accurate, on-time delivery of your order, every time, that's our aim. Just what you need, right when you need it.

## Anyplace, Anywhere, Anytime...

**Atlas Copco is a world leading supplier in the Mining and Rock Excavation sector.**

The Group delivers sustainable solutions for increased customer productivity through innovative products and services. Atlas Copco was founded in 1873. Today it has a global reach spanning more than 170 countries.

We are committed to sustainable productivity which means that we do everything we can to ensure reliable, lasting results with responsible use of resources; human, natural, and capital.

# WHERE TO FIND US

Please contact your local Atlas Copco CustomerCenter.  
or visit [www.atlascopco.com](http://www.atlascopco.com) and select country, or contact:  
Atlas Copco Drilling Solutions LLC, Garland, Texas, USA  
Telephone: +1 (972) 496 7400



Country	City (HQ)	Phone no.
Albania	Tirana	+355 682 061618
Algeria	Zeralda	+213 (0)21 32 83 25 /26/27
Angola	Luanda	+244 929 303 139
Argentina	Buenos Aires	+54 (0) 3327 413 800
Australia	Blacktown	+61 (0)2-96219700
Austria	Vienna	+43 (0)1-760120
Belgium	Brussels	+32 (0)2-6890511
Bolivia	La Paz	+591 (0)2-2112000
Bosnia & Herzegovina	Sarajevo	+387 33674391
Botswana	Gaborone	+267 3959155
Brazil	São Paulo	+55 (11)-34788200
Bulgaria	Sofia	+359 (0)2-4893178
Burkina Faso	Ouagadougou	+226 50365610
Canada	Mississauga	+1 (289) 562-0010
	North Bay	+1 (0)705-4723320
Chile	Santiago	+56 (0)2-24423600
Croatia	Zagreb	+385 (0)1-6111288
China	Beijing office	+86 (0)10-65280517
	Nanjing	+86 (0)25-85757500
Colombia	Bogotá	+57 (0)1-4199200
Cyprus	Nicosia	+357 (0)22-480740
Czech Republic	Praha	+420 225 434 220
DR of Congo	Lubumbashi	+243 (0) 991 004 430
Denmark	Glostrup	+45 43454611
Egypt	Cairo	+20 (0)2-6102057
Estonia	Finland, Vantaa	+358 (0)20 718 9300
Finland	Vantaa	+358 (0)20 718 9300
France	Saint Ouen l'Aumône	+33 (0)1-39093222
Germany	Essen	+49 (0)201-21770
Ghana	Accra	+233 (0)302 774512
Great Britain	Hemel Hempstead	+44 (0)1442-222100
Greece	Koropi, Athens	+30 (0)210-3499600
India	Pune	+91 (0)20-30722222
Indonesia	Jakarta	+62 (0)21-7801008
Iran	Tehran	+98 (0)21-66937711
Ireland	Dublin	+353 (0)1-4505978
Italy	Milan	+39 (0)2-617991
Japan	Tokyo	+81 (0)3-57657890
Kazakhstan	Almaty	+7 (0)727-2588534
Kenya	Nairobi	+254 (0)20-6605000
South Korea	Seoul	+82 (0)2-21894000
Latvia	Finland, Vantaa	+358 (0)9-296442
Lithuania	Finland, Vantaa	+358 (0)9-296442
Macedonia	Skopje	+389 (0)2-3112383
Malaysia	Selangor	+60 (0)3-51238888
Mali	Bamako	+223 20 21 17 97
Mexico	Tlalnepantla	+52 55 2282 0600
Mongolia	Ulan Bator	+976 (0)11-344991
Morocco	Casablanca	+212 (0)522-634000
Namibia	Windhoek	+264 (0)61-261396
Netherlands	Zwijndrecht	+31 (0)78-6230230
New Zealand	Auckland	+64 (0)9-5794069
Nigeria	Abuja	+234 (0)70 68621253
Norway	Oslo	+47 64860300
Pakistan	Lahore	+92 (0)42 35749406
Panama	Panama City	+507 8306155
Peru	Lima	+51 (0)1-224 8680
Philippines	Manila	+63 (0)2-8430535 to 39
Poland	Raszyn	+48 (0)22-5726800
Portugal	Lisbon	+351 214 168500
Romania	Bucharest	+40 262 218212
Russia	Moscow	+7 (495)-9335552
Saudi Arabia	Jeddah	+966 (0)2-6933357
Singapore	Jurong	+65 6210-8000
Slovenia	Trzin	+386 (0)1-5600710
South Africa	Witfield	+27 (0)11-8219000
Spain	Madrid	+34 (0)916-279100
Sweden	Stockholm	+46 (0)8-7439230
Switzerland	Studen/Biel	+41 (0)32-3741581
Taiwan	Taoyuan Hsien	+886 (0)3-4796838
Thailand	Bangkok	+66 (0)-38562900
Turkey	Istanbul	+90 (0)216-5810581
United Arab Emirates	Dubai	+971 4-8861996
Ukraine	Kiev	+38 (0)44)4991871
USA	Denver, Colorado	+1 800-7326762
Venezuela	Caracas	+58 (0)212-2562311
Vietnam	Ho Chi Minh	+84 (0)8-38989638
Zambia	Chingola	+260 (0)2-311281
Zimbabwe	Harare	+263 (0)4-621761







# *Sustainable Productivity*

We stand by our responsibilities towards our customers,  
towards the environment and the people around us.  
We make performance stand the test of time.  
This is what we call – Sustainable Productivity

## **Atlas Copco Drilling Solutions LLC**

2100 North First Street, Garland, TX 75040 - USA

Phone: +1 (972) 496-74000

[www.atlascopco.com/wwdrills](http://www.atlascopco.com/wwdrills)

<http://www.atlascopco.com/oilandgasus/>

